

symbol description

electrical connectors



Zinc Plated Steel screws



Zinc Plated Steel nuts



Hexagonal crimp



Radial crimp



Indent crimp



Deep indent crimp



Oval crimp



Trapezium crimp



Circular crimp



Semicircular crimp



Indent crimp



Operating temperature range



Degree of protection



UL LISTING Marking valid in USA & CANADA



UL LISTING Marking valid in USA & CANADA



In accordance with DIN 46235



Meets the requirements for fire testing of materials and components for trains EN 45545-2:2015



Halogen free



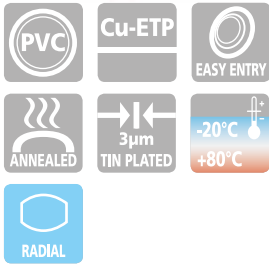

The unique funnel shaped PVC sleeve guarantees total insertion of the conductor strands into the terminal barrel, creating a secure and reliable, electrical and mechanical connection. The internal surface of the barrel is rifled to improve contact with conductor strands when crimped and to increase tensile strength. The "F" range of terminals offers a wide selection of rings, forks, pins and blades, designed to meet the ever changing end user requirements.

The PVC insulation, is a self extinguishing thermoplastic material class V0 (UL 94). The operating temperature range is -20 to +80°C (Surge +90°C). Recommended crimping tools are shown on pages 144 to 173, 260.



pin terminals

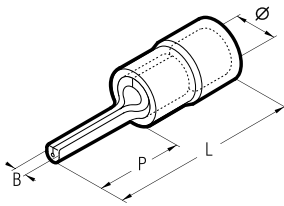

Conductor Size sqmm (AWG)	Type	Dimensions mm				Quantity Box/Bag
		Ø	B	P	L	
0,25÷1,5 (22÷16)	RF-P8	4,0	1,6	8,0	17,8	3.000/100
	RF-P10	4,0	1,6	10,0	19,8	3.000/100
	RF-P12	4,0	1,6	12,0	22,0	3.000/100
1,5÷2,5 (16÷14)	BF-P8	4,9	1,6	8,0	17,8	2.500/100
	BF-P10	4,9	1,6	10,0	19,8	2.500/100
	BF-P12	4,9	1,6	12,0	21,8	2.500/100
4÷6 (12÷10)	GF-P10	6,6	2,2	10,0	24,5	1.000/100
	GF-P12	6,6	2,2	12,0	26,7	1.000/100
	GF-P14	6,6	2,2	14,0	28,7	1.000/100

blade terminals

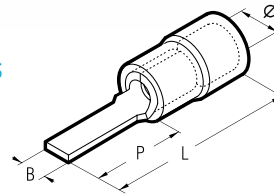

Conductor Size sqmm (AWG)	Type	Dimensions mm				Quantity Box/Bag
		Ø	B	P	L	
0,25÷1,5 (22÷16)	RF-PP12	4,0	3,0	12,8	22,8	3.000/100
	RF-PP12/1	4,0	3,0	11,3	21,3	3.000/100
	RF-PP12/19	4,0	1,9	13,2	23,2	3.000/100
	RF-PP12/23	4,0	2,3	13,2	23,2	2.500/100
	RF-PP14	4,0	3,0	14,8	24,8	2.500/100
	RF-PP16/23	4,0	2,3	17,2	27,2	2.500/100
1,5÷2,5 (16÷14)	BF-PP10	4,9	3,5	10,0	20,0	2.500/100
	BF-PP12	4,9	3,5	12,8	22,8	2.500/100
	BF-PP12/25	4,9	2,5	13,3	23,3	2.000/100
	BF-PP12/29*	4,9	2,9	13,3	23,3	2.500/100
	BF-PP16/25	4,9	2,5	17,2	27,2	2.500/100
	GF-PP12	6,6	4,0	13,3	27,4	1.000/100
4÷6 (12÷10)	GF-PP17	6,6	2,9	19,2	33,3	1.000/100

hooked blade terminals

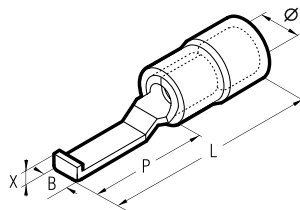

Conductor Size sqmm (AWG)	Type	Dimensions mm					Quantity Box/Bag
		Ø	B	P	L	X	
0,25÷1,5 (22÷16)	RF-PPL30*	4,0	3,0	17,5	28,3	1,7	2.500/100
	RF-PPL46*	4,0	4,6	17,5	28,3	1,7	2.500/100
1,5÷2,5 (16÷14)	BF-PPL30*	4,9	3,0	17,5	28,3	1,7	2.000/100
	BF-PPL46*	4,9	4,6	17,5	28,3	1,7	2.000/100
4÷6 (12÷10)	GF-PPL46*	6,6	4,6	17,5	32,6	1,9	1.000/100

*Not UL approved

PVC INSULATED CRIMP TERMINALS

RF BF GF

F range funnel entry - for Copper conductors



NEW

VALSTAR-N4



Robust plastic case with compartments, containing:

- An assortment of PVC insulated crimp terminals for conductor sizes 0,25 to 6 mm² (22÷10 AWG).
- Cable ties
- Tool Crimpstar® HP3.

Connectors included:

- Qty 100 terminals RF-M4
- Qty 100 terminals BF-M5
- Qty 100 terminals GF-M6
- Qty 100 terminals RF-F608P
- Qty 100 terminals BF-F608P
- Qty 100 connectors PL03-M
- Qty 100 cable ties G100X2.5

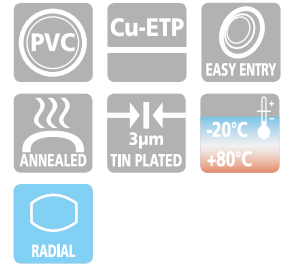

ring terminals

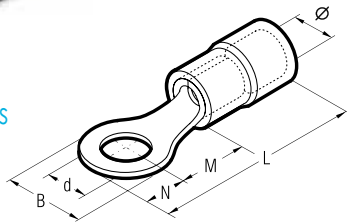

fork/spade terminals

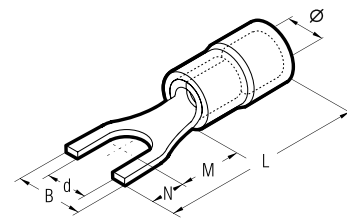

Conductor Size sqmm (AWG)	Ø Stud mm	Type	Dimensions mm						Quantity Box/Bag
			Ø	B	M	N	L	d	
0,25÷1,5 (22÷16)	2	RF-M2**	4,0	5,6	4,5	2,8	17,3	2,2	3.000/100
	3	RF-M3	4,0	5,6	4,5	2,8	17,3	3,2	3.000/100
	3,5	RF-M3.5	4,0	5,6	4,5	2,8	17,3	3,7	3.000/100
	3,5	RF-M3.5/1	4,0	6,2	7,1	3,1	20,2	3,7	3.000/100
	4	RF-M4	4,0	7,0	6,5	3,5	20,0	4,3	3.000/100
	4	RF-M4/3*	4,0	7,8	7,1	3,9	21,0	4,3	3.000/100
	5	RF-M5	4,0	7,8	7,1	3,9	21,0	5,3	2.500/100
	6	RF-M6	4,0	9,4	8,1	4,7	22,8	6,4	2.500/100
	6	RF-M6/1	4,0	12,0	10,3	6,0	26,3	6,4	2.000/100
	7	RF-M7	4,0	9,4	8,1	4,7	22,8	7,2	2.500/100
	8	RF-M8	4,0	12,0	10,3	6,0	26,3	8,4	2.000/100
	10	RF-M10	4,0	15,5	13,0	7,7	30,8	10,5	1.500/100
12	RF-M12	4,0	18,0	15,5	9,0	34,5	13,0	1.500/100	
1,5÷2,5 (16÷14)	2	BF-M2**	4,9	5,6	5,0	2,8	17,8	2,2	3.000/100
	3	BF-M3	4,9	5,6	5,0	2,8	17,8	3,2	2.500/100
	3,5	BF-M3.5	4,9	5,6	5,0	2,8	17,8	3,7	2.500/100
	3,5	BF-M3.5/1	4,9	6,2	6,5	3,1	19,6	3,7	2.500/100
	4	BF-M4	4,9	8,0	6,5	4,0	20,5	4,3	2.500/100
	5	BF-M5	4,9	8,0	7,5	4,0	21,5	5,3	2.000/100
	6	BF-M6	4,9	9,4	8,6	4,7	23,3	6,4	2.000/100
	6	BF-M6/1	4,9	12,0	10,3	6,0	26,3	6,4	2.000/100
	6	BF-M6/2**	4,9	8,4	5,4	4,2	19,6	6,4	2.500/100
	7	BF-M7	4,9	10,0	7,8	5,0	22,8	7,2	2.000/100
	8	BF-M8	4,9	12,0	10,3	6,0	26,3	8,4	1.500/100
	10	BF-M10	4,9	15,5	13,0	7,7	30,8	10,5	1.500/100
12	BF-M12	4,9	18	15,5	9,0	34,5	13,0	1.000/100	
4÷6 (12÷10)	3	GF-M3	6,6	8,0	8,1	4,0	26,2	3,2	1.000/100
	3,5	GF-M3.5	6,6	8,0	8,1	4,0	26,2	3,7	1.000/100
	4	GF-M4	6,6	9,0	8,1	4,5	26,7	4,3	1.000/100
	5	GF-M5	6,6	9,0	8,1	4,5	26,7	5,3	1.000/100
	6	GF-M6	6,6	11,0	11,1	5,5	30,7	6,4	1.000/100
	6	GF-M6/1	6,6	11,0	8,1	5,5	27,7	6,4	1.000/100
	7	GF-M7	6,6	11,0	11,1	5,5	30,7	7,2	1.000/100
	8	GF-M8	6,6	13,6	12,1	6,8	33,0	8,4	800/100
	8	GF-M8/1**	6,6	11,0	8,1	5,5	27,7	8,4	1.000/100
	10	GF-M10	6,6	13,6	12,1	6,8	33,0	10,5	800/100
	10	GF-M10/1	6,6	15,5	13,8	7,7	35,7	10,5	800/100
	12	GF-M12	6,6	19,0	15,1	9,5	38,7	13,0	500/100
	14	GF-M14	6,6	21,0	16,1	10,5	40,7	15,0	500/100
	16	GF-M16	6,6	24,0	17,1	12,0	43,2	17,0	500/100

Conductor Size sqmm (AWG)	Ø Stud mm	Type	Dimensions mm						Quantity Box/Bag
			Ø	B	M	N	L	d	
0,25÷1,5 (22÷16)	3	RF-U3	4,0	5,5	5,5	4,0	19,5	3,2	3.000/100
	3,5	RF-U3.5	4,0	6,0	6,5	3,8	20,3	3,7	3.000/100
	3,5	RF-U3.5/1	4,0	7,2	6,5	3,8	20,3	3,7	3.000/100
	3,5	RF-U3.5/2*	4,0	6,4	6,5	3,8	20,3	3,7	3.000/100
	4	RF-U4	4,0	6,5	7,5	3,7	21,2	4,3	3.000/100
	4	RF-U4/1	4,0	8,5	7,5	3,7	21,2	4,3	3.000/100
	4	RF-U4/2	4,0	7,5	7,5	3,7	21,2	4,3	3.000/100
	5	RF-U5	4,0	8,5	7,5	3,7	21,2	5,3	2.500/100
	5	RF-U5/1**	4,0	9,4	7,5	3,7	21,2	5,3	3.000/100
	6	RF-U6	4,0	9,4	8,1	4,7	22,8	6,4	2.000/100
	6	RF-U6/1	4,0	12,0	9,2	7,1	26,3	6,4	2.000/100
	8	RF-U8	4,0	14,0	10,0	6,3	26,3	8,4	2.000/100
10	RF-U10	4,0	17,5	13,0	7,7	30,8	10,5	1.500/100	
12	RF-U12	4,0	20,0	15,5	9,0	34,5	13,0	1.500/100	
1,5÷2,5 (16÷14)	3	BF-U3	4,9	5,5	5,5	4,0	19,5	3,2	2.500/100
	3,5	BF-U3.5	4,9	6,4	6,5	3,8	20,3	3,7	2.500/100
	3,5	BF-U3.5/1*	4,9	7,2	6,5	3,8	20,3	3,7	3.000/100
	4	BF-U4	4,9	6,5	7,5	3,7	21,2	4,3	3.000/100
	4	BF-U4/1	4,9	8,5	7,5	3,7	21,2	4,3	2.000/100
	4	BF-U4/2	4,9	7,5	7,5	3,7	21,2	4,3	2.000/100
	5	BF-U5	4,9	8,5	7,5	3,7	21,2	5,3	2.000/100
	5	BF-U5/2*	4,9	12,0	11,3	5,0	26,3	5,3	1.500/100
	6	BF-U6	4,9	9,4	8,1	4,7	22,8	6,4	2.000/100
	6	BF-U6/1	4,9	12,0	9,2	7,1	26,3	6,4	2.000/100
	8	BF-U8	4,9	14,0	10,0	6,3	26,3	8,4	1.500/100
	10	BF-U10	4,9	17,5	13,0	7,7	30,8	10,5	1.000/100
12	BF-U12	4,9	20,0	15,5	9,0	34,5	13,0	1.000/100	
4÷6 (12÷10)	3,5	GF-U3.5	6,6	7,5	8,5	3,9	26,5	3,7	1.000/100
	4	GF-U4	6,6	7,5	8,0	4,4	26,5	4,3	1.000/100
	5	GF-U5	6,6	9,5	8,0	4,4	26,5	5,3	1.000/100
	6	GF-U6	6,6	10,0	11,0	5,5	30,6	6,4	1.000/100
	8	GF-U8	6,6	13,5	12,0	8,0	34,1	8,4	800/100
	10	GF-U10	6,6	15,5	13,0	8,0	35,1	10,5	1.000/100
	10	GF-U10/1	6,6	17,5	13,8	7,7	35,7	10,5	1.000/100
	12	GF-U12	6,6	21,0	15,1	9,5	38,7	13,0	500/100
14	GF-U14	6,6	23,0	16,1	10,5	40,7	15,0	500/100	
16	GF-U16	6,6	26,0	17,1	11,5	42,7	17,0	500/100	

*Not UL approved *Made to order

RF-F BF-F GF-F

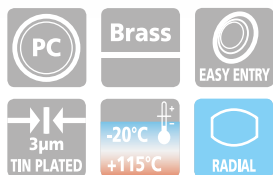

* Material: Polycarbonate type PC10500AC certified EN45545-2









FEMALE DISCONNECT TERMINALS

for Copper conductors









Recommended crimping tools are shown on pages 144 to 173, 260.



Polycarbonate* insulated terminals partially reinforced with Copper sleeve

Conductor Size sqmm (AWG)	Type	Tab Size mm	Quantity Box/Bag
0,25÷1,5 (22÷16)	 RF-F305	2,8 x 0,5	3.000/100
	 RF-F308*	2,8 x 0,8	3.000/100
	 RF-F405	4,8 x 0,5	2.500/100
	 RF-F408	4,8 x 0,8	2.500/100
1,5÷2,5 (16÷14)	 RF-F608	6,35 x 0,8	2.500/100
	 BF-F405	4,8 x 0,5	2.500/100
	 BF-F408	4,8 x 0,8	2.500/100
4÷6 (12÷10)	 BF-F608	6,35 x 0,8	1.500/100
	 GF-F608	6,35 x 0,8	1.000/100

Polycarbonate* fully insulated terminals partially reinforced with Copper sleeve

Conductor Size sqmm (AWG)	Type	Tab Size mm	Quantity Box/Bag
0,25÷1,5 (22÷16)	 RF-F305P	2,8 x 0,5	2.000/100
	 RF-F308P*	2,8 x 0,8	2.000/100
	 RF-F405P	4,8 x 0,5	1.500/100
	 RF-F408P	4,8 x 0,8	1.500/100
1,5÷2,5 (16÷14)	 RF-F608P	6,35 x 0,8	1.000/100
	 BF-F405P	4,8 x 0,5	1.500/100
	 BF-F408P	4,8 x 0,8	1.500/100
4÷6 (12÷10)	 BF-F608P	6,35 x 0,8	1.000/100
	 GF-F608P	6,35 x 0,8	800/100

RF-M BF-M GF-M



* Material: Polycarbonate type PC10500AC certified EN45545-2



MALE DISCONNECT TERMINALS

for Copper conductors



Recommended crimping tools are shown on pages 144 to 173, 260.



Polycarbonate* insulated terminals partially reinforced with Copper sleeve

Conductor Size sqmm (AWG)	Type	Tab Size mm	Quantity Box/Bag
0,25÷1,5 (22÷16)	 RF-M608	6,35 x 0,8	3.000/100
1,5÷2,5 (16÷14)	 BF-M608	6,35 x 0,8	2.000/100
	 GF-M608	6,35 x 0,8	1.000/100

Polycarbonate* fully insulated terminals partially reinforced with Copper sleeve

Conductor Size sqmm (AWG)	Type	Tab Size mm	Quantity Box/Bag
0,25÷1,5 (22÷16)	 RF-M608P	6,35 x 0,8	1.000/100
1,5÷2,5 (16÷14)	 BF-M608P	6,35 x 0,8	800/100

RF-FM BF-FM RF-B BF-B

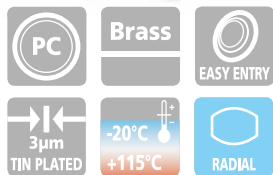



* Material: Polycarbonate type PC10500AC certified EN45545-2

MALE/FEMALE

for Copper conductors

Recommended crimping tools are shown on pages 144 to 173, 260.

Polycarbonate* insulated terminals partially reinforced with Copper sleeve





Conductor Size sqmm (AWG)	Type	Tab Size mm	Quantity Box/Bag
0,25÷1,5 (22÷16)	 RF-FM608	6,35 x 0,8	1.000/100
1,5÷2,5 (16÷14)	 BF-FM608	6,35 x 0,8	1.000/100

BULLET AND SOCKET

for Copper conductors



Polycarbonate* insulated terminals partially reinforced with Copper sleeve

Conductor Size sqmm (AWG)	Type	Ø mm	Quantity Box/Bag
0,25÷1,5 (22÷16)	 RF-BM4*	4,0	2.500/100
	 RF-BF4*	3,95	800/100
1,5÷2,5 (16÷14)	 BF-BM5*	5,0	2.000/100
	 BF-BF5*	4,95	800/100

*Not UL approved

BUTT AND PARALLEL CONNECTORS

for Copper conductors



butt connectors

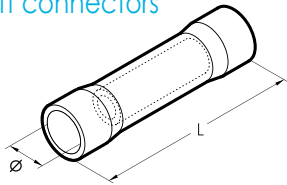

parallel connectors

Recommended crimping tools are shown on pages 144 to 173, 260.

PVC insulated

Conductor Size sqmm (AWG)	Type	ø mm	L mm	Quantity Box/Bag
0,2÷0,5 (24÷20)	PL01-M*	3,0	25,0	3.000/100
0,25÷1,5 (22÷16)	PL03-M	4,0	25,0	1.000/100
1,5÷2,5 (16÷14)	PL06-M	5,0	25,0	1.500/100
4÷6 (12÷10)	PL1-M	6,5	32,0	500/100
0,25÷1,5 (22÷16)	PL03-P*	4,0	20,0	3.000/100
1,5÷2,5 (16÷14)	PL06-P*	5,0	16,0	2.000/100

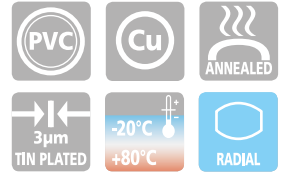

BUTT CONNECTORS

for Copper conductors

Recommended crimping tools are shown on pages 144 to 173, 260.

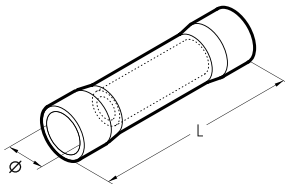

Polyamide PA6.6 insulated

Conductor Size sqmm (AWG)	Type	ø mm	L mm	Quantity Box/Bag
0,25÷1,5 (22÷16)	NL03-M	4,0	25,0	1.000/100
1,5÷2,5 (16÷14)	NL06-M	5,4	25,5	1.500/100
4÷6 (12÷10)	NL1-M	7,6	32,0	500/100
10 (8÷7)	NL2-M	8,0	43,0	500/100
16 (6÷5)	NL3-M	9,2	44,0	400/100

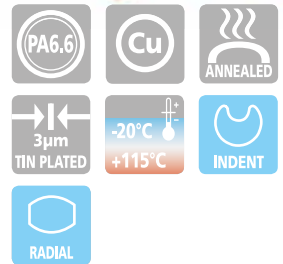

Recommended crimping tools are shown on pages 146, 158-159.

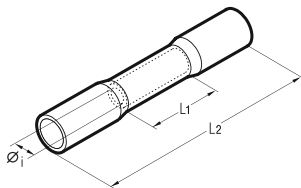

PE HD insulated, heat shrinkable

Conductor Size sqmm (AWG)	Type	ø mm	L1 mm	L2 mm	Quantity Box/Bag
0,5÷1,5 (20÷16)	WL03-M	1,7	15,0	36,0	1.500/100
1,5÷2,5 (16÷14)	WL06-M	2,3	15,0	36,0	1.000/100
4÷6 (12÷10)	WL1-M	3,5	15,0	41,0	500/100

- Max operating voltage: 600 V
- Shrink temperature: 150 °C
- Protection: IP68



CLOSE END CONNECTORS

for Copper conductors

Recommended crimping tools are shown on pages 144 to 173, 260.

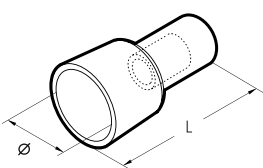

Polyamide PA6.6 insulated

Conductor Size sqmm (AWG)	Type	ø mm	L mm	Quantity Box/Bag
0,25÷1,5 (22÷16)	NL03-P	7,9	21,0	1.000/100
1,5÷2,5 (16÷14)	NL06-P	7,9	19,9	1.000/100
	NL06-PB	6,5	13,6	1.500/100
4÷6 (12÷10)	NL1-P	10,5	21,5	500/100
	NL1-PG	9,0	17,8	1.000/100



*Not UL approved

VP RP BP GP

HALOGEN FREE INSULATED TERMINALS

P range funnel entry - for Copper conductors

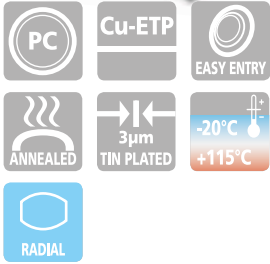

The "P" range of terminals has been designed, to meet the increasing demands for improved safety and reliability of electrical connectors.

The Polycarbonate insulation type PC10500AC certified EN45545-2, is a Halogen free, self extinguishing thermoplastic material class V0 (UL 94). The unique funnel shaped entry of the insulation sleeve, guarantees total insertion of the con-

ductor strands into the terminal barrel, creating a secure and reliable, electrical and mechanical connection.

The operating temperature range is -20 to +115°C (Surge +130°C).

Recommended crimping tools are shown on pages 144 to 173, 260.



pin terminals

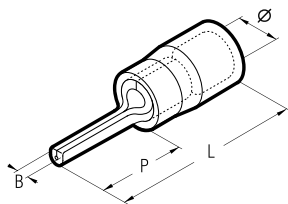

Conductor Size sqmm (AWG)	Type	Dimensions mm				Quantity Box/Bag
		Ø	B	P	L	
0,2÷0,5 (24÷20)	VP-P10	3,0	1,0	9,8	20,2	4.000/100
0,25÷1,5 (22÷16)	RP-P8	4,0	1,6	7,8	17,9	3.000/100
	RP-P10	4,0	1,6	9,8	19,9	3.000/100
1,5÷2,5 (16÷14)	RP-P12	4,0	1,6	12,0	22,1	3.000/100
	BP-P8	4,9	1,6	7,8	17,9	3.000/100
4÷6 (12÷10)	BP-P10	4,9	1,6	9,8	19,9	3.000/100
	BP-P12	4,9	1,6	11,8	21,9	2.500/100
4÷6 (12÷10)	GP-P10	6,6	2,2	10,4	24,5	1.000/100
	GP-P12	6,6	2,2	12,6	26,7	1.000/100
	GP-P14	6,6	2,2	14,6	28,7	1.000/100

blade terminals

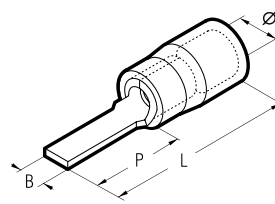

Conductor Size sqmm (AWG)	Type	Dimensions mm				Quantity Box/Bag
		Ø	B	P	L	
0,2÷0,5 (24÷20)	VP-PP12/19	3,0	1,9	12,4	22,4	4.000/100
0,25÷1,5 (22÷16)	RP-PP12	4,0	3,0	12,8	22,9	3.000/100
	RP-PP12/1	4,0	3,0	11,3	21,4	3.000/100
	RP-PP12/19	4,0	1,9	13,2	23,3	3.000/100
	RP-PP12/23	4,0	2,3	13,2	23,3	2.500/100
	RP-PP14	4,0	3,0	14,8	24,9	2.500/100
	RP-PP16/23	4,0	2,3	17,2	27,3	2.500/100
1,5÷2,5 (16÷14)	BP-PP12	4,9	3,5	12,8	22,9	2.500/100
	BP-PP12/25	4,9	2,5	13,3	23,4	2.000/100
	BP-PP12/29	4,9	2,9	13,3	23,4	2.500/100
	BP-PP16/25	4,9	2,5	17,2	27,3	2.500/100
4÷6 (12÷10)	GP-PP12	6,6	4,0	13,3	27,4	1.000/100
	GP-PP17	6,6	2,9	19,1	33,2	1.000/100

hooked blade terminals

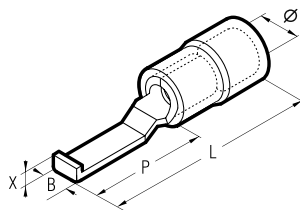

Conductor Size sqmm (AWG)	Type	Dimensions mm					Quantity Box/Bag
		Ø	B	P	L	X	
0,25÷1,5 (22÷16)	RP-PPL30	4,0	3,0	17,5	28,3	1,7	3.000/100
	RP-PPL46	4,0	4,6	17,5	28,3	1,7	3.000/100
1,5÷2,5 (16÷14)	BP-PPL30	4,9	3,0	17,5	28,3	1,7	2.500/100
	BP-PPL46	4,9	4,6	17,5	28,8	1,7	2.500/100
4÷6 (12÷10)	GP-PPL46	6,6	4,6	17,5	32,6	1,9	1.000/100

*Not UL approved

HALOGEN FREE INSULATED TERMINALS

P range funnel entry - for Copper conductors

VP RP
BP GP

ring terminals

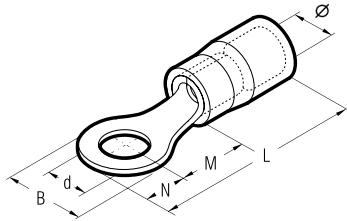

fork/spade terminals

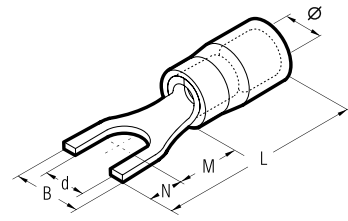

Cond. Size sqmm (AWG)	Ø Stud mm	Type	Dimensions mm						Quantity Box/Bag
			Ø	B	M	N	L	d	
0,25÷0,5 (24÷20)	3,0	2 VP-M2*	3,0	5,6	4,5	2,8	17,5	2,2	4.000/100
		3 VP-M3	3,0	5,6	4,5	2,8	17,5	3,2	4.000/100
		3,5 VP-M3.5	3,0	5,6	4,5	2,8	17,5	3,7	4.000/100
		4 VP-M4	3,0	7,0	6,5	3,5	20,2	4,3	4.000/100
		5 VP-M5	3,0	7,8	7,1	3,9	21,2	5,3	4.000/100
		6 VP-M6*	3,0	9,4	8,1	4,7	23,0	6,4	4.000/100
0,25÷1,5 (22÷16)	4,0	2 RP-M2*	4,0	5,6	4,5	2,8	17,4	2,2	3.000/100
		3 RP-M3	4,0	5,6	4,5	2,8	17,4	3,2	3.000/100
		3,5 RP-M3.5	4,0	5,6	4,5	2,8	17,4	3,7	3.000/100
		3,5 RP-M3.5/1	4,0	6,2	7,1	3,1	20,2	3,7	3.000/100
		4 RP-M4	4,0	7,0	6,5	3,5	20,1	4,3	3.000/100
		4 RP-M4/3	4,0	7,8	7,1	3,9	21,1	4,3	3.000/100
		5 RP-M5	4,0	7,8	7,1	3,9	21,1	5,3	2.500/100
		6 RP-M6	4,0	9,4	8,1	4,7	22,9	6,4	2.500/100
		6 RP-M6/1	4,0	12,0	10,3	6,0	26,4	6,4	2.000/100
		7 RP-M7	4,0	9,4	8,1	4,7	22,9	7,2	2.500/100
		8 RP-M8	4,0	12,0	10,3	6,0	26,4	8,4	2.500/100
		10 RP-M10	4,0	15,5	13,0	7,7	30,9	10,5	1.500/100
12 RP-M12	4,0	18,0	15,5	9,0	34,6	13,0	1.500/100		
1,5÷2,5 (16÷14)	4,9	2 BP-M2*	4,9	5,6	5,0	2,8	17,9	2,2	2.500/100
		3 BP-M3	4,9	5,6	5,0	2,8	17,9	3,2	2.500/100
		3,5 BP-M3.5	4,9	5,6	5,0	2,8	17,9	3,7	3.000/100
		3,5 BP-M3.5/1	4,9	6,2	6,5	3,1	19,7	3,7	2.500/100
		4 BP-M4	4,9	8,0	6,5	4,0	20,6	4,3	2.500/100
		5 BP-M5	4,9	8,0	7,5	4,0	21,6	5,3	2.000/100
		6 BP-M6	4,9	9,4	8,6	4,7	23,4	6,4	2.000/100
		6 BP-M6/1	4,9	12,0	10,3	6,0	26,4	6,4	2.000/100
		6 BP-M6/2*	4,9	8,4	5,4	4,2	19,7	6,4	2.500/100
		7 BP-M7	4,9	10,0	7,8	5,0	22,9	7,2	2.500/100
		8 BP-M8	4,9	12,0	10,3	6,0	26,4	8,4	1.500/100
		10 BP-M10	4,9	15,5	13,0	7,7	30,9	10,5	1.500/100
12 BP-M12	4,9	18,0	15,5	9,0	34,6	13,0	1.000/100		
4÷6 (12÷10)	6,6	3 GP-M3	6,6	8,0	8,1	4,0	26,2	3,2	1.000/100
		3,5 GP-M3.5	6,6	8,0	8,1	4,0	26,2	3,7	1.500/100
		4 GP-M4	6,6	9,0	8,1	4,5	26,7	4,3	1.000/100
		5 GP-M5	6,6	9,0	8,1	4,5	26,7	5,3	1.000/100
		6 GP-M6	6,6	11,0	11,1	5,5	30,7	6,4	1.000/100
		6 GP-M6/1	6,6	11,0	11,1	5,5	27,7	6,4	1.000/100
		7 GP-M7	6,6	11,0	11,1	5,5	30,7	7,2	1.000/100
		8 GP-M8	6,6	13,6	12,1	6,8	33,0	8,4	800/100
		8 GP-M8/1*	6,6	11,0	8,1	5,5	27,7	8,4	1.000/100
		10 GP-M10	6,6	13,6	12,1	6,8	33,0	10,5	1.000/100
		10 GP-M10/1	6,6	15,5	13,8	7,7	35,7	10,5	1.000/100
		12 GP-M12	6,6	19,0	15,1	9,5	38,7	13,0	500/100
		14 GP-M14	6,6	21,0	16,1	10,5	40,7	15,0	500/100
		16 GP-M16	6,6	24,0	17,1	12,0	43,2	17,0	500/100

Cond. Size sqmm (AWG)	Ø Stud mm	Type	Dimensions mm						Quantity Box/Bag		
			Ø	B	M	N	L	d			
0,2÷0,5 (24÷20)	3,0	3 VP-U3	3,0	5,5	5,5	4,0	18,7	3,2	4.000/100		
		3,5 VP-U3.5	3,0	6,0	6,5	3,8	19,5	3,7	4.000/100		
		4 VP-U4	3,0	6,5	7,5	3,7	20,4	4,3	4.000/100		
		3 RP-U3	4,0	5,5	5,5	4,0	19,6	3,2	3.000/100		
0,25÷1,5 (22÷16)	4,0	3,5 RP-U3.5	4,0	6,0	6,5	3,8	20,4	3,7	3.000/100		
		3,5 RP-U3.5/2	4,0	6,4	6,5	3,8	20,4	3,7	3.000/100		
		4 RP-U4	4,0	6,5	7,5	3,7	21,3	4,3	3.000/100		
		4 RP-U4/1	4,0	8,5	7,5	3,7	21,3	4,3	3.000/100		
		4 RP-U4/2	4,0	7,5	7,5	3,7	21,3	4,3	3.500/100		
		5 RP-U5	4,0	8,5	7,5	3,7	21,3	5,3	3.000/100		
		5 RP-U5/1*	4,0	9,4	7,5	3,7	21,3	5,3	3.000/100		
		6 RP-U6	4,0	9,4	8,1	4,7	22,9	6,4	2.000/100		
		6 RP-U6/1	4,0	12,0	9,2	7,1	26,4	6,4	2.000/100		
		8 RP-U8	4,0	14,0	10,0	6,3	26,4	8,4	2.000/100		
		10 RP-U10	4,0	17,5	13,0	7,7	30,9	10,5	1.500/100		
		12 RP-U12	4,0	20,0	15,5	9,0	34,6	13,0	1.500/100		
		1,5÷2,5 (16÷14)	4,9	3 BP-U3	4,9	5,5	5,5	4,0	19,6	3,2	2.500/100
				3,5 BP-U3.5	4,9	6,4	6,5	3,8	20,4	3,7	2.500/100
				3,5 BP-U3.5/1*	4,9	7,2	6,5	3,8	20,4	3,7	2.500/100
				4 BP-U4	4,9	6,5	7,5	3,7	21,3	4,3	2.500/100
4 BP-U4/1	4,9			8,5	7,5	3,7	21,3	4,3	3.000/100		
4 BP-U4/2	4,9			7,5	7,5	3,7	21,3	4,3	2.000/100		
5 BP-U5	4,9			8,5	7,5	3,7	21,3	5,3	2.000/100		
6 BP-U6	4,9			9,4	8,1	4,7	22,9	6,4	2.000/100		
6 BP-U6/1	4,9			12,0	9,2	7,1	26,4	6,4	2.000/100		
8 BP-U8	4,9			14,0	10,0	6,3	26,4	8,4	1.500/100		
10 BP-U10	4,9			17,5	13,0	7,7	30,9	10,5	1.000/100		
12 BP-U12	4,9			20	15,5	9,0	34,6	13,0	1.500/100		
4÷6 (12÷10)	6,6			3,5 GP-U3.5	6,6	7,5	8,5	3,9	26,5	3,7	1.000/100
				4 GP-U4	6,6	7,5	8,0	4,4	26,5	4,3	1.000/100
				5 GP-U5	6,6	9,5	8,0	4,4	26,5	5,3	1.000/100
				6 GP-U6	6,6	10,0	11,0	5,5	30,6	6,4	1.000/100
		8 GP-U8	6,6	13,5	12,0	8,0	34,1	8,4	1.000/100		
		10 GP-U10	6,6	15,5	13,0	8,0	35,1	10,5	1.000/100		
		10 GP-U10/1	6,6	17,5	13,8	7,7	35,7	10,5	1.000/100		
		12 GP-U12	6,6	21,0	15,1	9,5	38,7	13,0	500/100		
		14 GP-U14	6,6	23,0	16,1	10,5	40,7	15,0	500/100		
		16 GP-U16	6,6	26,0	17,1	11,5	42,7	17,0	500/100		

*Made to order

CRP CBP CGP

INSULATED CHAIN TERMINALS

CP range with easy entry - for Copper conductors



The "CP" range of terminals has been designed to meet the increasing demands for improved safety and reliability of electrical connectors. Developed for use with production equipment, to give a quick and reliable crimped joint, the Polycarbonate insulation type PC10500AC certified EN45545-2, is a Halogen free, self extinguishing thermoplastic material class V0 (UL 94). The unique funnel shaped entry of the insulation sleeve guarantees

strands into the terminal barrel, creating a secure and reliable, electrical and mechanical connection. The operating temperature range is -20 to +115°C (Surge +130°C).

bonate insulation type PC10500AC certified EN45545-2, is a Halogen free, self extinguishing thermoplastic material class V0 (UL 94). The unique funnel shaped entry of the insulation sleeve guarantees



- PC**
- Cu-ETP**
- EASY ENTRY**
- EN 45545-2**
- HF HALOGEN FREE**
- ANNEALED**
- 3µm TIN PLATED**
- 20°C to +115°C**
- RADIAL**

pin terminals

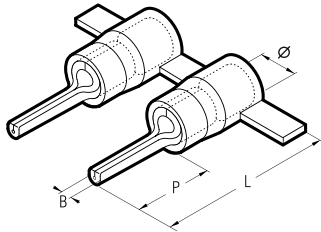

blade terminals

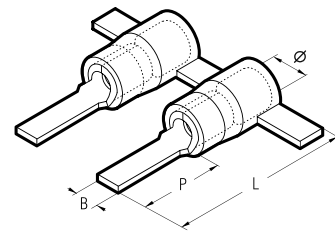

Conductor Size sqmm (AWG)	Type	Dimensions mm				Quantity
		Ø	B	P	L	
0,25÷1,5 (22÷16)	CRP-P8	4,0	1,6	8,0	17,9	2.000
	CRP-P10	4,0	1,6	10,0	19,9	2.000
	CRP-P12	4,0	1,6	12,0	22,1	2.000
1,5÷2,5 (16÷14)	CBP-P8	4,9	1,6	8,0	17,9	1.750
	CBP-P10	4,9	1,6	10,0	19,9	1.750
	CBP-P12	4,9	1,6	12,0	21,9	1.750
4÷6 (12÷10)	CGP-P10	6,6	2,2	10,0	24,5	1.250
	CGP-P12	6,6	2,2	12,0	26,7	1.250
	CGP-P14	6,6	2,2	14,0	28,7	1.250

Conductor Size sqmm (AWG)	Type	Dimensions mm				Quantity
		Ø	B	P	L	
0,25÷1,5 (22÷16)	CRP-PP12	4,0	3,0	12,8	22,9	2.000
	CRP-PP12/1*	4,0	3,0	11,3	21,4	2.000
	CRP-PP12/23*	4,0	2,3	13,2	23,3	2.000
	CRP-PP14	4,0	3,0	14,8	24,9	2.000
1,5÷2,5 (16÷14)	CBP-PP12	4,9	3,5	12,8	22,9	1.750
	CBP-PP12/25*	4,9	2,5	13,3	23,4	1.750
4÷6 (12÷10)	CGP-PP12	6,6	4,0	13,3	27,4	1.250
	CGP-PP17*	6,6	2,9	19,1	33,2	1.250

male disconnect terminals

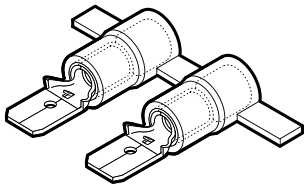

Conductor Size sqmm (AWG)	Type	Tab Size mm	Quantity
0,25÷1,5 (22÷16)	CRP-M608	6,35 x 0,8	2.000
	CBP-M608	6,35 x 0,8	1.750
4÷6 (12÷10)	CGP-M608	6,35 x 0,8	1.250

female disconnect terminals

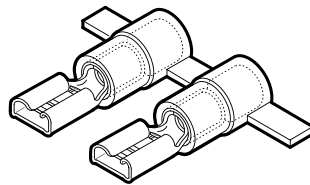

Conductor Size sqmm (AWG)	Type	Tab Size mm	Quantity
0,25÷1,5 (22÷16)	CRP-F305	2,8 x 0,5	2.000
	CRP-F308	2,8 x 0,8	2.000
	CRP-F405	4,8 x 0,5	2.000
	CRP-F408	4,8 x 0,8	2.000
	CRP-F608	6,35 x 0,8	2.000
1,5÷2,5 (16÷14)	CBP-F405	4,8 x 0,5	1.750
	CBP-F408	4,8 x 0,8	1.750
	CBP-F608	6,35 x 0,8	1.750
4÷6 (12÷10)	CGP-F608	6,35 x 0,8	1.250

female disconnect terminals fully insulated

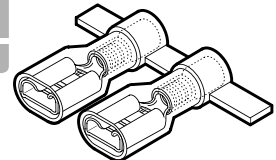

Conductor Size sqmm (AWG)	Type	Tab Size mm	Quantity
0,25÷1,5 (22÷16)	CRP-F405P*	4,8 x 0,5	2.000
	CRP-F408P*	4,8 x 0,8	2.000
	CRP-F608P*	6,35 x 0,8	1.500
1,5÷2,5 (16÷14)	CBP-F408P*	4,8 x 0,8	1.500
	CBP-F608P*	6,35 x 0,8	1.500
4÷6 (12÷10)	CGP-F608P*	6,35 x 0,8	1.250

*Not UL approved *Made to order

INSULATED CHAIN TERMINALS

CP range with easy entry - for Copper conductors

CRP CBP CGP

fork/spade terminals

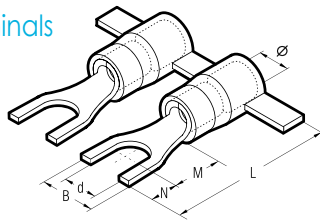

Cond. Size sqmm (AWG)	Ø Stud mm	Type	Dimensions mm					Quantity	
			Ø	B	M	N	L		d
0,25÷1,5 (22÷16)	3	CRP-U3	4,0	5,5	5,5	4,0	19,6	3,2	2.000
	3,5	CRP-U3.5	4,0	6,0	6,5	3,8	20,4	3,7	2.000
	3,5	CRP-U3.5/2*	4,0	6,4	6,5	3,8	20,4	3,7	2.000
	4	CRP-U4	4,0	6,5	7,5	3,7	21,3	4,3	2.000
	4	CRP-U4/1*	4,0	8,5	7,5	3,7	21,3	4,3	2.000
	4	CRP-U4/2*	4,0	7,5	7,5	3,7	21,3	4,3	2.000
	5	CRP-U5	4,0	8,5	7,5	3,7	21,3	5,3	2.000
	6	CRP-U6	4,0	9,4	8,1	4,7	22,9	6,4	2.000
1,5÷2,5 (16÷14)	6	CRP-U6/1*	4,0	12,0	9,2	7,1	26,4	6,4	2.000
	8	CRP-U8*	4,0	14,0	10,0	6,3	26,4	8,4	2.000
	3	CBP-U3	4,9	5,5	5,5	4,0	19,6	3,2	1.750
	3,5	CBP-U3.5	4,9	6,4	6,5	3,8	20,4	3,7	1.750
	4	CBP-U4	4,9	6,5	7,5	3,7	21,3	4,3	1.750
	4	CBP-U4/1*	4,9	8,5	7,5	3,7	21,3	4,3	1.750
4÷6 (12÷10)	4	CBP-U4/2*	4,9	7,5	7,5	3,7	21,3	4,3	1.750
	5	CBP-U5	4,9	8,5	7,5	3,7	21,3	5,3	1.750
	6	CBP-U6	4,9	9,4	8,1	4,7	22,9	6,4	1.750
	3,5	CGP-U3.5*	6,6	7,5	8,5	3,9	26,5	3,7	1.250
	4	CGP-U4*	6,6	7,5	8,0	4,4	26,5	4,3	1.250
	5	CGP-U5	6,6	9,5	8,0	4,4	26,5	5,3	1.250

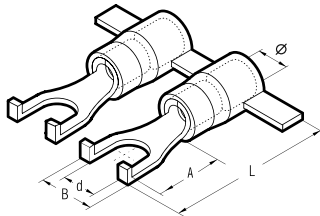

Cond. Size sqmm (AWG)	Ø Stud mm	Type	Dimensions mm					Quantity
			Ø	B	A	L	d	
1,5÷2,5 (16÷14)	4	CBP-U 4/3L*	4,9	6,5	9,5	14,5	4,3	1.750

hooked blade terminals

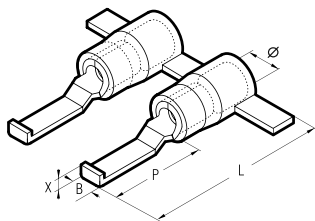

Cond. Size sqmm (AWG)	Type	Dimensions mm					Quantity
		Ø	B	P	L	X	
0,25÷1,5 (22÷16)	CRP-PPL30*	4,0	3,0	17,5	28,8	1,7	2.000
1,5÷2,5 (16÷14)	CBP-PPL30*	4,9	3,0	17,5	28,8	1,7	1.750

ring terminals

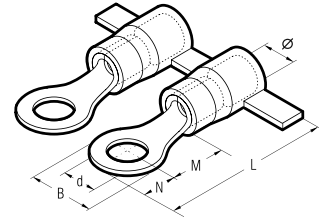

Cond. Size sqmm (AWG)	Ø Stud mm	Type	Dimensions mm					Quantity	
			Ø	B	M	N	L		d
0,25÷1,5 (22÷16)	3	CRP-M3	4,0	5,6	4,5	2,8	17,4	3,2	2.000
	3,5	CRP-M3.5*	4,0	5,6	4,5	2,8	17,4	3,7	2.000
	3,5	CRP-M3.5/1	4,0	6,2	7,1	3,1	20,2	3,7	2.000
	4	CRP-M4	4,0	7,0	6,5	3,5	20,1	4,3	2.000
	4	CRP-M4/3*	4,0	7,8	7,1	3,9	21,1	4,3	2.000
	5	CRP-M5	4,0	7,8	7,1	3,9	21,1	5,3	2.000
	6	CRP-M6	4,0	9,4	8,1	4,7	22,9	6,4	2.000
	6	CRP-M6/1*	4,0	12,0	10,3	6,0	26,4	6,4	2.000
1,5÷2,5 (16÷14)	7	CRP-M7	4,0	9,4	8,1	4,7	22,9	7,2	2.000
	8	CRP-M8	4,0	12,0	10,3	6,0	26,4	8,4	2.000
	3	CBP-M3	4,9	5,6	5,0	2,8	17,9	3,2	1.750
	3,5	CBP-M3.5	4,9	5,6	5,0	2,8	17,9	3,7	1.750
	3,5	CBP-M3.5/1*	4,9	6,2	6,5	3,1	19,6	3,7	1.750
	4	CBP-M4	4,9	8,0	6,5	4,0	20,6	4,3	1.750
	5	CBP-M5	4,9	8,0	7,5	4,0	21,6	5,3	1.750
	6	CBP-M6	4,9	9,4	8,6	4,7	23,4	6,4	1.750
4÷6 (12÷10)	6	CBP-M6/1*	4,9	12,0	10,3	6,0	26,4	6,4	1.750
	7	CBP-M7	4,9	10,0	7,8	5,0	22,9	7,2	1.750
	8	CBP-M8	4,9	12,0	10,3	6,0	26,4	8,4	1.750
	3	CGP-M3	6,6	8,0	8,1	4,0	26,2	3,2	1.250
	3,5	CGP-M3.5	6,6	8,0	8,1	4,0	26,2	3,7	1.250
	4	CGP-M4	6,6	9,0	8,1	4,5	26,7	4,3	1.250
	5	CGP-M5	6,6	9,0	8,1	4,5	26,7	5,3	1.250
	6	CGP-M6	6,6	11,0	11,1	5,5	30,7	6,4	1.250
	6	CGP-M6/1*	6,6	11,0	8,1	5,5	27,7	6,4	1.250
	7	CGP-M7	6,6	11,0	11,1	5,5	30,7	7,2	1.000
8	CGP-M8	6,6	13,6	12,1	6,8	33,0	8,4	1.250	
8	CGP-M8/1*	6,6	11,0	8,1	5,5	27,7	8,4	1.250	
10	CGP-M10	6,6	13,6	12,1	6,8	33,0	10,5	1.250	



Interchangeable application heads are available for crimping these terminals with the bench press ELB-3 (see page 176).

*Not UL approved *Made to order

RKY BKY GKY

REINFORCED PA 6.6 INSULATED TERMINALS

KY range - for Copper conductors

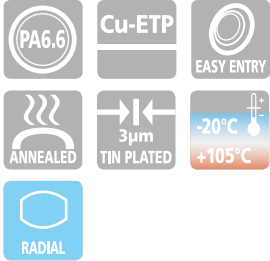

'KY' type terminals are designed to offer improved mechanical and electrical integrity under heavy-duty application.

This is achieved via a Copper sleeve located between the Copper barrel and Polyamide insulation of the terminal. Then, during crimping, the insulation of the conductor is integrated into the crimp due to the Copper sleeve being deformed around it to maintain the level of 'grip' required in applications subject to continuous mechanical vibrations (e.g: mobile plant, vehicles, moving components).

The operating temperature range

is -20 to +105°C (Surge +110°C). Recommended crimping tools are shown on pages 144 to 173, 260.



HF
HALOGEN
FREE

pin terminals

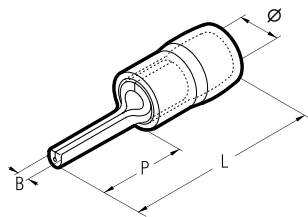

Conductor Size sqmm (AWG)	Type	Dimensions mm				Quantity Box/Bag
		Ø	B	P	L	
0,25÷1,5 (22÷16)	RKY-P8	4,5	1,9	9,0	19,8	3.000/100
	RKY-P10	4,5	1,9	10,0	20,8	3.500/100
	RKY-P12	4,5	1,9	12,0	22,8	3.000/100
1,5÷2,5 (16÷14)	BKY-P8	5,2	1,9	9,0	19,8	3.000/100
	BKY-P10	5,2	1,9	10,0	20,8	3.000/100
	BKY-P12	5,2	1,9	12,0	22,8	3.000/100
4÷6 (12÷10)	GKY-P14	7,0	2,8	14,0	27,0	1.000/100

blade terminals

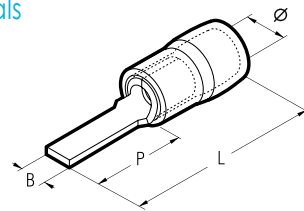

Conductor Size sqmm (AWG)	Type	Dimensions mm				Quantity Box/Bag
		Ø	B	P	L	
0,25÷1,5 (22÷16)	RKY-PP12	4,5	3,0	13,0	23,8	3.000/100
	RKY-PP12/19	4,5	2,0	18,0	28,8	3.000/100
	RKY-PP16/23	4,5	2,2	18,0	28,8	2.500/100
1,5÷2,5 (16÷14)	BKY-PP12	5,2	3,0	13,0	23,8	2.500/100
	BKY-PP12/25	5,2	2,4	13,0	23,8	2.000/100
	BKY-PP16/23	5,2	2,2	18,0	28,8	2.500/100
4÷6 (12÷10)	GKY-PP12	7,0	4,0	14,0	27,0	1.000/100
	GKY-PP17	7,0	2,0	18,0	31,0	1.000/100

hooked blade terminals

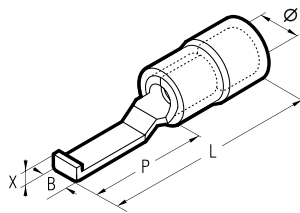

Conductor Size sqmm (AWG)	Type	Dimensions mm					Quantity Box/Bag
		Ø	B	P	L	X	
0,25÷1,5 (22÷16)	RKY-PPL30	4,5	3,0	16,8	28,2	2,1	3.000/100
	RKY-PPL46	4,5	4,6	16,8	28,2	2,1	3.000/100
1,5÷2,5 (16÷14)	BKY-PPL30	5,2	3,0	16,8	28,2	2,1	2.500/100
	BKY-PPL46	5,2	4,6	16,8	28,2	2,1	2.500/100
4÷6 (12÷10)	GKY-PPL46	7,0	4,6	17,2	30,2	2,4	1.000/100

Consult CEMBRE for a wider range of pin and blade dimensions.

REINFORCED PA 6.6 INSULATED TERMINALS

KY range - for Copper conductors

RKY BKY GKY

ring terminals

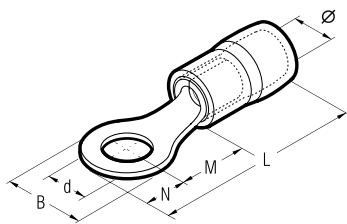

Cond. Size sqmm (AWG)	Ø Stud mm	Type	Dimensions mm						Quantity Box/Bag
			Ø	B	M	N	L	d	
0,25÷1,5 (22÷16)	3	RKY-M3	4,5	5,5	5,0	2,5	18,5	3,2	3.000/100
	3,5	RKY-M3.5	4,5	5,5	5,0	2,5	18,5	3,7	3.000/100
	3,5	RKY-M3.5/1	4,5	6,6	6,3	3,1	20,4	3,7	3.000/100
	4	RKY-M4	4,5	6,6	6,3	3,1	20,4	4,3	3.000/100
	5	RKY-M5	4,5	8,0	7,0	3,8	21,8	5,3	2.500/100
	6	RKY-M6/1	4,5	11,6	11,0	5,8	27,8	6,4	2.000/100
	8	RKY-M8	4,5	11,6	11,0	5,8	27,8	8,4	2.500/100
	10	RKY-M10	4,5	13,6	13,9	6,6	31,5	10,5	1.500/100
	12	RKY-M12	4,5	19,6	16,0	9,4	36,4	13,0	1.500/100
	3	BKY-M3	5,2	6,6	4,8	3,0	18,8	3,2	2.500/100
	3,5	BKY-M3.5	5,2	6,6	4,8	3,0	18,8	3,7	2.500/100
	1,5÷2,5 (16÷14)	3,5	BKY-M3.5/1	5,2	6,6	6,3	3,1	20,4	3,7
4		BKY-M4	5,2	8,5	7,8	4,0	22,8	4,3	2.500/100
5		BKY-M5	5,2	8,5	7,8	4,0	22,8	5,3	2.500/100
6		BKY-M6/1	5,2	12,0	11,0	5,8	27,8	6,4	2.000/100
8		BKY-M8	5,2	12,0	11,0	5,8	27,8	8,4	1.500/100
10		BKY-M10	5,2	13,6	13,9	6,6	31,5	10,5	1.500/100
4÷6 (12÷10)	12	BKY-M12	5,2	19,2	16,0	9,4	36,4	13,0	1.000/100
	3,5	GKY-M3.5	7,0	7,2	6,1	3,6	22,7	3,7	1.000/100
	4	GKY-M4	7,0	9,5	9,1	4,5	26,6	4,3	1.000/100
	5	GKY-M5	7,0	9,5	9,1	4,5	26,6	5,3	1.000/100
	6	GKY-M6	7,0	12,0	10,5	6,0	29,5	6,4	1.000/100
	8	GKY-M8	7,0	15,0	13,5	7,5	34,0	8,4	1.000/100
	10	GKY-M10	7,0	15,0	13,5	7,5	34,0	10,5	1.000/100
	12	GKY-M12	7,0	19,2	16,0	9,6	38,6	13,0	1.000/100
14	GKY-M14	7,0	32,0	25,2	16,0	54,2	15,0	500/100	
16	GKY-M16	7,0	32,0	25,2	16,0	54,2	17,0	500/100	

fork/spade terminals

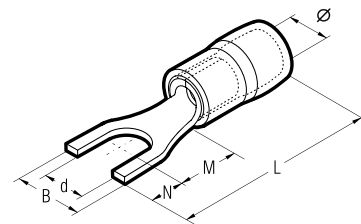

Cond. Size sqmm (AWG)	Ø Stud mm	Type	Dimensions mm						Quantity Box/Bag
			Ø	B	M	N	L	d	
0,25÷1,5 (22÷16)	3	RKY-U3	4,5	5,7	6,5	4,5	22,0	3,2	2.500/100
	3,5	RKY-U3.5	4,5	5,7	6,5	4,5	22,0	3,7	2.500/100
	4	RKY-U4	4,5	6,4	6,5	4,5	22,0	4,3	3.000/100
	5	RKY-U5	4,5	8,1	6,5	4,5	22,0	5,3	3.000/100
	6	RKY-U6	4,5	9,5	6,5	4,5	22,0	6,4	2.000/100
	6	RKY-U6/1	4,5	12,0	11,0	6,0	28,0	6,4	2.000/100
1,5÷2,5 (16÷14)	3	BKY-U3	5,2	5,7	6,5	4,5	22,0	3,2	2.500/100
	3,5	BKY-U3.5	5,2	6,0	6,5	4,5	22,0	3,7	2.500/100
	4	BKY-U4	5,2	6,4	6,5	4,5	22,0	4,3	2.500/100
	5	BKY-U5	5,2	7,9	6,5	4,5	22,0	5,3	2.000/100
	6	BKY-U6	5,2	9,3	6,5	4,5	22,0	6,4	2.000/100
	6	BKY-U6/1	5,2	12,0	11,0	6,0	28,0	6,4	2.000/100
4÷6 (12÷10)	3,5	GKY-U3.5	7,0	7,2	7,5	3,9	24,4	3,7	1.000/100
	4	GKY-U4	7,0	7,2	7,5	3,9	24,4	4,3	1.000/100
	5	GKY-U5	7,0	9,0	7,0	5,5	25,5	5,3	1.000/100
	6	GKY-U6	7,0	12,0	12,0	6,5	31,5	6,4	1.000/100
8	GKY-U8	7,0	14,0	10,5	7,0	30,5	8,4	1.000/100	

Consult CEMBRE for a wider range of pin and blade dimensions.

RKF-F BKF-F GK-F

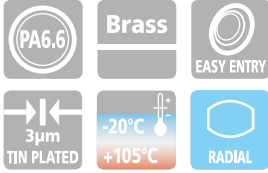

Recommended crimping tools are shown on pages 144 to 173, 260.

female connectors, fully reinforced with Copper sleeve

PA6.6 insulated terminals

Conductor Size sqmm (AWG)	Type	Tab Size mm	Quantity Box/Bag
0,25÷1,5 (22÷16)	RKF-F305	2,8 x 0,5	3.000/100
	RKF-F308	2,8 x 0,8	3.000/100
	RKF-F405	4,8 x 0,5	2.500/100
	RKF-F408	4,8 x 0,8	2.500/100
1,5÷2,5 (16÷14)	RKF-F608	6,35 x 0,8	2.500/100
	BKF-F405	4,8 x 0,5	2.500/100
	BKF-F408	4,8 x 0,8	2.500/100
4÷6 (12÷10)	GK-F608	6,35 x 0,8	1.500/100

PA6.6 fully insulated terminals

Conductor Size sqmm (AWG)	Type	Tab Size mm	Quantity Box/Bag
0,25÷1,5 (22÷16)	RKF-F405P	4,8 x 0,5	1.500/100
	RKF-F408P	4,8 x 0,8	2.000/100
1,5÷2,5 (16÷14)	RKF-F608P	6,35 x 0,8	1.000/100
	BKF-F405P	4,8 x 0,5	1.500/100
4÷6 (12÷10)	BKF-F408P	4,8 x 0,8	2.000/100
	GK-F608P	6,35 x 0,8	1.000/100

HF
HALOGEN
FREE

RKF BKF GKF



male connectors, fully reinforced with Copper sleeve - PA6.6 insulated terminals

Conductor Size sqmm (AWG)	Type	Tab Size mm	Quantity Box/Bag
0,25÷1,5 (22÷16)	RKF-M608	6,35 x 0,8	3.000/100
1,5÷2,5 (16÷14)	BKF-M608	6,35 x 0,8	2.500/100
4÷6 (12÷10)	GKF-M608	6,35 x 0,8	1.000/100

male/female connectors, fully reinforced with Copper sleeve PA6.6 insulated terminals

Conductor Size sqmm (AWG)	Type	Tab Size mm	Quantity Box/Bag
0,25÷1,5 (22÷16)	RKF-FM608	6,35 x 0,8	1.500/100
1,5÷2,5 (16÷14)	BKF-FM608	6,35 x 0,8	1.500/100

Recommended crimping tools are shown on pages 144 to 173, 260.

HF
HALOGEN
FREE

bullet and socket connectors fully reinforced with Copper sleeve PA6.6 insulated terminals

Conductor Size sqmm (AWG)	Type	Ø mm	Quantity Box/Bag
0,25÷1,5 (22÷16)	RKF-BM4	4,0	2.500/100
	RKF-BF4	3,95	1.000/100
1,5÷2,5 (16÷14)	BKF-BM4	4,0	2.000/100
	BKF-BF4	3,95	800/100

RN-FA BN-FA



Recommended crimping tools are shown on pages 144 to 173, 260.

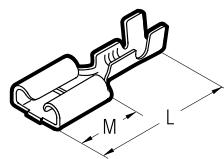

FEMALE CONNECTORS

for Copper conductors

Conductor Size sqmm (AWG)	Type	Tab Size mm	M mm	L mm	Quantity Box/Bag
0,5÷1 (20÷17)	RN-FA305	2,8 x 0,5	6,3	15,0	6.000/100
	RN-FA405	4,8 x 0,5	6,3	15,0	5.000/100
	RN-FA608	6,3 x 0,8	7,7	19,0	3.000/100
1÷2,5 (17÷14)	BN-FA608	6,3 x 0,8	7,7	19,0	2.000/100
	BN-FAB608*	6,3 x 0,8	7,7	15,5	2.000/100
	BN-FAR608**	6,3 x 0,8	7,7	19,0	3.000/100

*flag type **with retainer

MALE CONNECTORS

open barrel - for Copper conductors

Conductor Size sqmm (AWG)	Type	Tab Size mm	M mm	L mm	Quantity Box/Bag
0,5÷1 (20÷17)	RN-MA305	2,8 x 0,5	5,8	13,0	6.000/100
	RN-MA405	4,8 x 0,5	6,3	17,3	5.000/100
	RN-MA608	6,3 x 0,8	7,9	19,7	4.000/100
1÷2,5 (17÷14)	BN-MA608	6,3 x 0,8	7,9	20,0	4.000/100

Recommended crimping tools are shown on pages 144 to 173, 260.

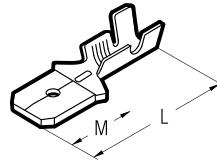

RN-MA BN-MA

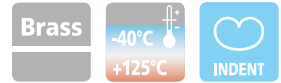

MALE TABS

for board mounting - for Copper conductors

Type	Tab Size mm	Ø Stud mm	B mm	C mm	α	Quantity Box/Bag
MP608	6,3 x 0,8	4,0	8,0	11,0	0°	5.000/100
MP608/45	6,3 x 0,8	4,0	8,0	8,5	45°	6.000/100
MP608/90	6,3 x 0,8	4,0	8,0	8,5	90°	5.000/100
MP608D*	6,3 x 0,8	5,0	8,0	14,0	0°	5.000/100

*double tab

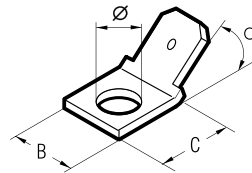

MP MPD



CONNECTOR SLEEVES

Type	Connector	B mm	M mm	L mm	Material	Quantity Box/Bag
CFA300	Female 2,8	5,5	7	18	Polyethylene	3.000/100
CFA400*	Female 4,8	7,5	9	20	Polyethylene	2.000/100
CFA600*	Female 6,3	9,0	11	24	Polyethylene	1.000/100
CFA2-600**	Female 6,3	9,0	9	22	Polyethylene	1.000/100
CFAR600	Female 6,3 with retainer	9,0	12	25	Polyamide 6.6	500/100
CFAB600	Female 6,3 flag	10,0	-	18	Polyamide 6.6	500/50
CMA600*	Male 6,3	12,0	11	22	Polyethylene	500/100

CFA CMA

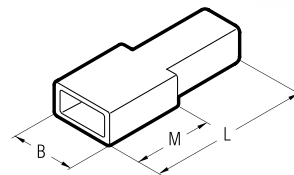

*For a single cable.
Colours available:
Transparent: no suffix
Red: add suffix R
Black: add suffix N

**For twin cables.
Colours available:
Transparent: no suffix
Red: add suffix R
Black: add suffix N
Green: add suffix V
Blue: add suffix B
Yellow: add suffix G

Max operating temperature:

- CFA300; CFA400; CFA600; CFA2-600; CMA600 (PE) 65°C
- CFAR600; CFAB600 (PA.6.6) 105°C

PKD

PA6 INSULATED END SLEEVES

for flexible Copper conductors



VALSTAR-N3 NEW

Comprising:

- a selection of end sleeves PKC conductor size 1÷6 sqmm
- Cable ties type G100X2
- tool ZKE610N.

VALSTAR-N2 NEW

Comprising:

- a selection of end sleeves PKC conductor size 1÷6 sqmm
- Cable ties type G100X2
- tool ZKE610N

VALSTAR-N1 NEW

Comprising:

- a selection of end sleeves PKC conductor size 1÷6 sqmm
- Cable ties type G100X2
- tool ZKE610N

The PK.. range of end sleeves is manufactured from Tin plated electrolytic Copper with a purity greater than 99.9%.

Designed and developed to reinforce fine wire strands when terminating a cable into a connector block. The PKD series of insulated end sleeves comply with specification DIN 46228/4.

The operating temperature range is -20 to +115°C (Surge +130°C). Recommended crimping tools are shown on pages 144 to 175, 227-229, 260, 262, 264-267.

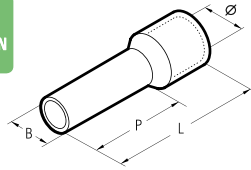

Conductor Size sqmm	Type	Dimensions mm				Insulation Colour	Quantity Box/Bag
		Ø	B	P	L		
0,3÷0,5	PKD506	2,6	1,4	6,0	12,0	○ white	10.000/500
	PKD508	2,6	1,4	8,0	14,0		10.000/500
	PKD510	2,6	1,4	10,0	16,0		10.000/500
0,75	PKD7506	2,8	1,6	6,0	12,0	● grey	10.000/500
	PKD7508	2,8	1,6	8,0	14,0		10.000/500
	PKD7510	2,8	1,6	10,0	16,0		10.000/500
	PKD7512	2,8	1,6	12,0	18,0		10.000/500
1	PKD106	3,0	1,8	6,0	12,0	● red	10.000/500
	PKD108	3,0	1,8	8,0	14,0		10.000/500
	PKD110	3,0	1,8	10,0	16,0		10.000/500
	PKD112	3,0	1,8	12,0	18,0		8.000/500
	PKD1508	3,5	2,1	8,0	14,0		5.000/500
1,5	PKD1510	3,5	2,1	10,0	16,0	● black	5.000/500
	PKD1512	3,5	2,1	12,0	18,0		5.000/500
	PKD1518	3,5	2,1	18,0	24,0		5.000/500
2,5	PKD2508	4,2	2,6	8,0	14,0	● blue	5.000/500
	PKD2512	4,2	2,6	12,0	18,0		4.000/500
	PKD2518	4,2	2,6	18,0	24,0		5.000/500
4	PKD410	4,8	3,3	10,0	18,0	● grey	3.000/200
	PKD412	4,8	3,3	12,0	20,0		3.000/200
	PKD418	4,8	3,3	18,0	26,0		3.000/200
6	PKD612	6,3	4,0	12,0	20,0	● yellow	1.500/100
	PKD618	6,3	4,0	18,0	26,0		1.500/100
10	PKD1012	7,6	5,0	12,0	22,0	● red	1.000/100
	PKD1018	7,6	5,0	18,0	28,0		1.000/100
16	PKD1612	8,8	6,4	12,0	24,0	● blue	800/100
	PKD1618	8,8	6,4	18,0	28,0		1.000/100
25	PKD25016	11,2	7,9	16,0	30,0	● yellow	400/50
	PKD25022	11,2	7,9	22,0	36,0		400/50
35	PKD35016	12,7	8,9	16,0	30,0	● red	300/50
	PKD35025	12,7	8,9	25,0	39,0		200/50
50	PKD50020	15,0	11,0	20,0	36,0	● blue	200/50
	PKD50025	15,0	11,0	25,0	41,0		200/50

PKE

PA6 INSULATED END SLEEVES

for flexible Copper conductors

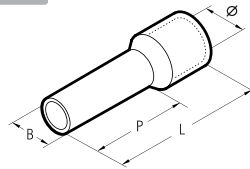

Conductor Size sqmm	Type	Dimensions mm				Insulation Colour	Quantity Box/Bag
		Ø	B	P	L		
0,1÷0,3	PKE308*	1,9	1,1	8,0	12,0	● yellow	20.000/500
0,3÷0,5	PKE508*	2,6	1,4	8,0	14,0	○ white	10.000/500
0,75	PKE7508	2,8	1,6	8,0	14,0	● blue	10.000/500
1	PKE108*	3,0	1,8	8,0	14,0	● red	10.000/500
	PKE1508*	3,5	2,1	8,0	14,0		5.000/500
1,5	PKE1510*	3,5	2,1	10,0	16,0	● black	5.000/500
	PKE1518*	3,5	2,1	18,0	24,0		5.000/500
	PKE2508	4,2	2,6	8,0	14,0		5.000/500
2,5	PKE2512	4,2	2,6	12,0	18,0	● grey	4.000/500
	PKE2518	4,2	2,6	18,0	24,0		3.000/500
	PKE410	4,8	3,3	10,0	18,0		3.000/200
4	PKE412	4,8	3,3	12,0	20,0	● orange	3.000/200
	PKE418	4,8	3,3	18,0	26,0		3.000/200
	PKE612	6,3	4,0	12,0	20,0		1.500/100
6	PKE618	6,3	4,0	18,0	26,0	● green	1.500/100
	PKE1012	7,6	5,0	12,0	22,0		1.000/100
10	PKE1018	7,6	5,0	18,0	28,0	● brown	1.000/100
	PKE1612	8,8	6,2	12,0	23,0		800/100
16	PKE1618	8,8	6,2	18,0	29,0	○ ivory	1.000/100
	PKE25016	11,2	7,9	16,0	30,0		400/50
25	PKE25022	11,2	7,9	22,0	36,0	● black	400/50

*to DIN standard 46 228/4 *Not UL approved

PA6 INSULATED END SLEEVES

for flexible Copper conductors

PKC

Conductor Size sqmm	Type	Dimensions mm				Insulation Colour	Quantity Box/Bag
		Ø	B	P	L		
0,1÷0,3	PKC306*	1,9	1,1	6,0	10,0	turquoise	20.000/500
	PKC308*	1,9	1,1	8,0	12,0		20.000/500
0,3÷0,5	PKC508	2,6	1,4	8,0	14,0	orange	10.000/500
	PKC510	2,6	1,4	10,0	16,0		10.000/500
0,75	PKC7508	2,8	1,6	8,0	14,0	white	10.000/500
	PKC7512	2,8	1,6	12,0	18,0		10.000/500
1	PKC108	3,0	1,8	8,0	14,0	yellow	10.000/500
	PKC112	3,0	1,8	12,0	18,0		7.500/500
1,5	PKC1508	3,5	2,1	8,0	14,0	red	5.000/500
	PKC1510	3,5	2,1	10,0	16,0		5.000/500
	PKC1518	3,5	2,1	18,0	24,0		5.000/500
2,5	PKC2508*	4,2	2,6	8,0	14,0	blue	5.000/500
	PKC2512*	4,2	2,6	12,0	18,0		5.000/500
	PKC2518*	4,2	2,6	18,0	24,0		5.000/500
4	PKC410*	4,8	3,3	10,0	18,0	grey	3.000/200
	PKC412*	4,8	3,3	12,0	20,0		3.000/200
	PKC418*	4,8	3,3	18,0	26,0		3.000/200
6	PKC612	6,3	4,0	12,0	20,0	black	1.500/100
	PKC618	6,3	4,0	18,0	26,0		1.500/100
10	PKC1012	7,6	5,0	12,0	22,0	ivory	1.000/100
	PKC1018	7,6	5,0	18,0	28,0		1.000/100
16	PKC1612	8,8	6,2	12,0	23,0	green	800/100
	PKC1618	8,8	6,2	18,0	29,0		1.000/100
25	PKC25016	11,2	7,9	16,0	30,0	brown	400/50
	PKC25022	11,2	7,9	22,0	36,0		500/50
35	PKC35016	12,7	8,9	16,0	30,0	beige	300/50
	PKC35025	12,7	8,9	25,0	39,0		300/50
50	PKC50020	15,0	11,0	20,0	36,0	olive	200/50
	PKC50025	15,0	11,0	25,0	41,0		200/50
70	PKC70022*	16,0	14,3	22,0	38,0	yellow	100/25
95	PKC95025*	18,0	15,7	25,0	44,0	red	100/25
120	PKC120027*	21,0	17,5	27,0	48,0	blue	100/25

*to DIN standard 46 228/4 *Not UL approved

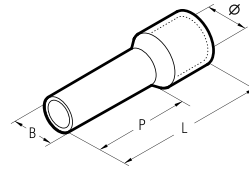

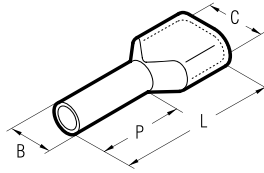

for International Market (excluding UK)

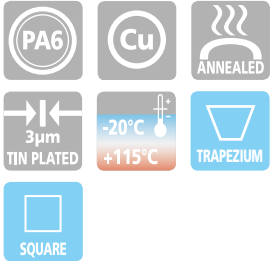

Type PKT range of end sleeves is manufactured from Tin plated electrolytic Copper. Designed to accommodate two cables terminating in the same sleeve. The operating temperature range is -20 to +115°C (Surge +130°C).

Recommended crimping tools are shown on pages 144 to 175, 227-229, 260, 262, 264-267.

Conductor Size sqmm	Type	Dimensions mm				Insulation Colour	ND1,ND2,ND3, ND4 and HNKE 50 Compression Aperture	Quantity Box/Bag
		C	B	P	L			
2 x 0,5	PKT508	4,7x2,6	1,8	8,0	14,0	○ white	1	5.000/500
	PKT510*	4,7x2,6	1,8	10,0	18,0			5.000/500
2 x 0,75	PKT7508	5,0x2,8	2,1	8,0	15,0	● grey	1,5	2.500/100
	PKT7510	5,0x2,8	2,1	10,0	17,0			2.500/100
2 x 1	PKT108	5,4x3,4	2,4	8,0	16,0	● red	2,5	2.500/100
	PKT110	5,4x3,4	2,4	10,0	18,0			2.500/100
2 x 1,5	PKT1508	6,6x3,6	2,6	8,0	16,0	● black	2,5	2.500/100
	PKT1512	6,6x3,6	2,6	12,0	20,0			2.500/100
2 x 2,5	PKT2510	7,8x4,2	3,2	10,0	20,0	● blue	4	2.000/100
	PKT2512	7,8x4,2	3,2	12,0	22,0			1.500/100
2 x 4	PKT412	8,8x4,9	4,2	12,0	23,0	● grey	6	1.000/100
2 x 6	PKT614	10,0x6,9	5,3	14,0	26,0	● yellow	10	800/100
2 x 10	PKT1014*	13,3x7,5	6,2	12,0	24,0	● red	16	500/50
2 x 16	PKT1614	18,6x9,6	8,9	14,0	30,0	● blue	35	300/50

*Not UL approved

"TWIN" POLYPROPYLENE INSULATED END SLEEVES

for fine stranded conductors - for UK Market

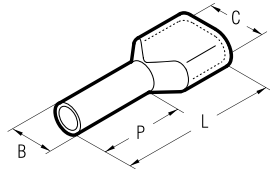

PKET PKCT



for UK Market 

Conductor Size sqmm	Type	Dimensions mm				Insulation Colour	ND1,ND2,ND3, ND4 and HNKE 50 Compression Aperture	Quantity Box/Bag
		C	B	P	L			
2 x 0,5	PKET508	4,6x2,4	1,8	8,0	15,0	○ white	1	500
2 x 0,75	PKET7508	5,4x2,7	2,1	8,0	15,0	● blue	1,5	500
	PKET7512	5,4x2,7	2,1	12,0	19,0			500
2 x 1	PKET108	5,3x2,3	2,35	8,0	15,0	● red	2,5	500
	PKET112	5,3x3,3	2,35	12,0	19,0			500
2 x 1,5	PKET1508	6,5x3,5	2,6	8,0	16,0	● black	2,5	500
	PKET1512	6,5x3,5	2,6	12,0	20,0		2,4	500
2 x 2,5	PKET2510	7,7x4,1	3,3	10,0	19,0	● grey	4	250
	PKET2512	7,7x4,1	3,3	12,0	22,0			250
2 x 4	PKET412	8,7x4,9	4,2	12,0	23,0	● orange	6	100
2 x 6	PKET614	9,9x6,1	5,3	14,0	25,0	● green	10	100
2 x 10	PKET1014	12,9x7,1	6,9	14,0	26,0	● brown	16	100
2 x 16	PKET1616	16,8x9,8	8,9	16,0	31,0	○ white	35	100

Conductor Size sqmm	Type	Dimensions mm				Insulation Colour	ND1,ND2,ND3, ND4 and HNKE 50 Compression Aperture	Quantity Box/Bag
		C	B	P	L			
2 x 0,5	PKCT508	4,6x2,4	1,8	8,0	15,0	● orange	1	500
2 x 0,75	PKCT7508	5,4x2,7	2,1	8,0	15,0	○ white	1,5	500
	PKCT7512	5,4x2,7	2,1	12,0	19,0			500
2 x 1	PKCT108	5,3x2,3	2,35	8,0	15,0	● yellow	2,5	500
	PKCT112	5,3x3,3	2,35	12,0	19,0			500
2 x 1,5	PKCT1508	6,5x3,5	2,6	8,0	16,0	● red	2,5	500
	PKCT1512	6,5x3,5	2,6	12,0	20,0		2,4	500
2 x 2,5	PKCT2510	7,7x4,1	3,3	10,0	19,0	● blue	4	250
	PKCT2512	7,7x4,1	3,3	12,0	22,0			250
2 x 4	PKCT412	8,7x4,9	4,2	12,0	23,0	● grey	6	100
2 x 6	PKCT614	9,9x6,1	5,3	14,0	25,0	● black	10	100
2 x 10	PKCT1014	12,9x7,1	6,9	14,0	26,0	○ ivory	16	100
2 x 16	PKCT1616	16,8x9,8	8,9	16,0	31,0	● green	35	100



Type PKET, PKCT ranges of twin end sleeves are manufactured from Tin plated electrolytic Copper with a purity greater than 99.9%.

Designed to accommodate two cables terminating in the same sleeve they are ideal for looping conductors.

The operating temperature range is -20 to +105°C (Surge +110°C).

Recommended crimping tools are shown on pages 144 to 175, 227-229, 260, 262, 264-267.

CPKD CPKC



Conforms to DIN standard 46228/4.

Interchangeable application heads are available for crimping these terminals with the bench press ELB-3 (see page 176).



POLYPROPYLENE INSULATED CHAIN END SLEEVES

for flexible Copper conductors

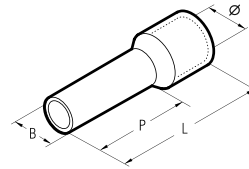

HF
HALOGEN
FREE

Conductor Size sqmm	Type	Dimensions mm				Insulation Colour	Quantity Box/Bag
		Ø	B	P	L		
0,3±0,5	CPKD508	2,6	1,3	8,0	14,0	○ white	5.000
0,75	CPKD7508	2,8	1,5	8,0	14,0	● grey	5.000
0,75	CPKC7508	2,8	1,5	8,0	14,0	○ white	5.000
1	CPKD108	3,0	1,7	8,0	14,0	● red	5.000
1,5	CPKD1508	3,5	2,0	8,0	14,0	● black	5.000
2,5	CPKD2508	4,2	2,5	8,0	14,0	● blue	3.000



KE

UNINSULATED END SLEEVES

for flexible Copper conductors



KE series end sleeves are manufactured from Tin plated electrolytic Copper of grade CW024A according to EN 12449, with purity greater than 99%. The compact geometry of the range allows for the termination of flexible conductors in confined spaces.

Recommended crimping tools are shown on pages 144 to 175, 227-229, 260, 262, 264-267.

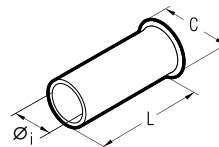

Conductor Size sqmm	Type	Dimensions mm			Quantity Box/Bag
		Ø	L	C	
0,5	KE506ST*	1,0	6,0	1,9	50.000/500
	KE508ST	1,0	8,0	1,9	50.000/500
0,75	KE7506ST*	1,2	6,0	2,2	40.000/500
	KE7508ST	1,2	8,0	2,2	40.000/500
1	KE106ST*	1,4	6,0	2,4	25.000/500
	KE110ST*	1,4	10,0	2,4	25.000/500
1,5	KE1508ST	1,7	8,0	2,8	25.000/500
	KE1510ST*	1,7	10,0	2,8	25.000/500
2,5	KE2508ST	2,2	8,0	3,4	20.000/500
	KE2510ST*	2,2	10,0	3,4	15.000/500
4	KE410ST	2,8	10,0	4,0	12.500/500
	KE412ST*	2,8	12,0	4,0	10.000/500
6	KE610ST*	3,5	10,0	4,7	10.000/500
	KE612ST*	3,5	12,0	4,7	7.500/500
	KE616ST*	3,5	15,0	4,7	5.000/500
10	KE1016ST*	4,5	15,0	5,8	4.000/250
16	KE1616ST*	5,8	15,0	7,5	3.000/250
25	KE25015ST	7,3	15,0	9,5	1.500/100
	KE25018ST*	7,3	18,0	9,5	1.500/100
35	KE35012ST	8,3	12,0	10,5	1.500/100
	KE35015ST	8,3	16,0	10,5	1.500/100
	KE35018ST*	8,3	18,0	10,5	1.000/100

*to DIN standard 46 228/1

COPPER TUBE CRIMPING LUGS PC INSULATED

P-M

for flexible Copper conductors - tested according to EN 45545-2:2013

HF
HALOGEN
FREE

EN
45545

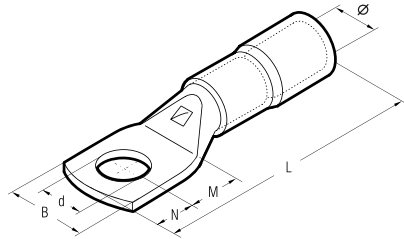

Conductor Size Flexible sqmm (AWG)	Ø Stud mm	Type	Dimensions mm						Insulation Colour	Quantity Box/Bag
			Ø	B	M	N	L	d		
0,25÷1,5 (22÷16)	3	P03-M3	4,0	6,0	4,5	3,5	22,0	3,2	Red	100
	3,5	P03-M3,5	4,0	6,5	4,5	3,5	22,0	3,7		100
	4	P03-M4	4,0	6,5	5,0	4,0	23,0	4,3		100
	5	P03-M5	4,0	7,5	5,5	4,5	24,0	5,3		100
1,5÷2,5 (16÷14)	6	P03-M6	4,0	9,0	6,0	5,0	25,0	6,4	100	
	3	P06-M3	4,9	6,0	4,5	3,5	22,6	3,2	Blue	100
	3,5	P06-M3,5	4,9	6,5	4,5	3,5	22,6	3,7		100
	4	P06-M4	4,9	7,5	5,0	4,0	23,6	4,3		100
	5	P06-M5	4,9	8,5	5,5	4,5	24,6	5,3		100
	6	P06-M6	4,9	9,0	6,0	5,0	25,6	6,4		100
8	P06-M8	4,9	12,0	9,0	8,0	31,3	8,4	100		
4÷6 (12÷10)	3	P1-M3	6,7	7,5	4,5	3,5	28,0	3,2	yellow	100
	3,5	P1-M3,5	6,7	7,5	4,5	3,5	28,0	3,7		100
	4	P1-M4	6,7	8,0	5,0	4,0	30,0	4,3		100
	5	P1-M5	6,7	9,0	6,5	6,0	32,3	5,3		100
	6	P1-M6	6,7	11,0	7,0	6,0	32,8	6,4		100
	8	P1-M8	6,7	14,0	9,0	8,0	36,8	8,4		100
	10	P1-M10	6,7	16,5	11,0	10,0	41,4	10,5		100
12	P1-M12	6,7	20,0	16,0	12,0	53,5	13,2	100		

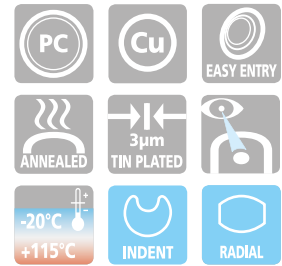

P-M series lugs are manufactured from electrolytic Copper tube with a purity greater than 99.9%, annealed and Tin plated.

The interior of the PA6.6 insulated sleeve is funnel shaped so as to ensure complete and easy introduction of the conductor strands. The P-M series lugs have the insulating sleeve in EN45545-2 certified PC10500AC type Polycarbonate, a halogen-free thermoplastic characterized, among other things, by a particular molecular structure which gives greater toughness compared to PVC and PA6.6.

- The operating temperature range is - 20 to + 115°C (Surge + 130°C).
- To install the P-M series lugs, use the HP3 or HP5 tools (see pages 144-145).

ANE-M

POLYAMIDE PA6.6 INSULATED COPPER TUBE LUGS

for Copper conductors

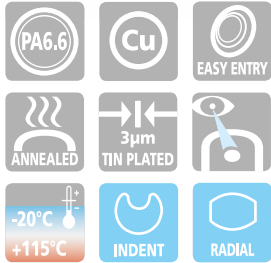
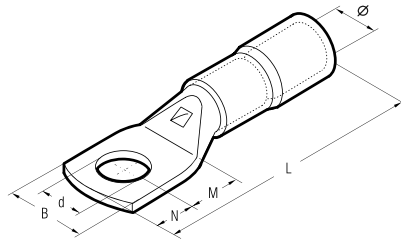

ANE-M series lugs are manufactured from electrolytic Copper tube with a purity greater than 99.9%, annealed and Tin plated. The interior of the PA6.6 insulated sleeve is funnel shaped so as to ensure complete and easy introduction of the conductor strands. It also eliminates the need to insulate the terminal using either tape or heat shrinkable tubing. Furthermore the PA6.6 sleeve avoids the possibility of conductor breakage at the barrel entrance. The operating temperature range is -20 to +115°C (Surge +130°C). In order to achieve the best electrical and mechanical performance it is suggested that they are crimped using dies and tools specifically developed for this purpose by CEMBRE.

Details of the appropriate crimping tools and dies are shown on pages 314 to 315.

Cond. Size Flexible sqmm	Ø Stud mm	Type	Dimensions mm						Quantity Box/Bag	Mechanical Tools		Hydraulic Tools	
			Ø	B	M	N	L	d					
10	4	ANE2-M4	8,0	10,0	5,0	4,0	34,1	4,3	500/100	HNN3	HNN4	B15MD	
	5	ANE2-M5	8,0	10,0	6,5	6,0	37,6	5,3	500/100				
	6	ANE2-M6	8,0	11,0	7,0	6,0	38,1	6,4	500/100				
	8	ANE2-M8	8,0	15,0	9,0	8,0	42,1	8,4	500/100				
	10	ANE2-M10	8,0	18,0	11,0	10,0	46,1	10,5	500/100				
16	4	ANE3-M4	9,2	11,5	5,0	4,0	38,6	4,3	400/100	HNN4	B15MD		
	5	ANE3-M5	9,2	11,5	6,5	6,0	42,1	5,3	400/100				
	6	ANE3-M6	9,2	11,5	7,0	6,0	42,6	6,4	400/100				
	8	ANE3-M8	9,2	15,0	9,0	8,0	46,6	8,4	400/100				
	10	ANE3-M10	9,2	18,0	11,0	10,0	50,6	10,5	300/100				
25	4	ANE5-M4	11,1	14,0	5,0	4,0	41,0	4,3	300/100	TNN70	B15MD		
	5	ANE5-M5	11,1	14,0	6,5	6,0	44,5	5,3	300/100				
	6	ANE5-M6	11,1	14,0	7,0	6,0	45,0	6,4	300/100				
	8	ANE5-M8	11,1	15,0	9,0	8,0	49,0	8,4	300/100				
	10	ANE5-M10	11,1	18,0	11,0	10,0	53,0	10,5	200/100				
35	6	ANE7-M6	13,6	17,0	7,0	6,0	50,0	6,4	100/50	TNN120	B15MD		
	8	ANE7-M8	13,6	17,0	9,0	8,0	54,0	8,4	100/50				
	10	ANE7-M10	13,6	19,0	11,0	10,0	58,0	10,5	100/50				
	12	ANE7-M12	13,6	21,0	14,0	12,0	63,0	13,2	100/50				
	50	6	ANE10-M6	13,8	19,0	8,0	7,0	53,0	6,4				150/50
8		ANE10-M8	13,8	19,0	9,0	8,0	55,0	8,4	150/50				
10		ANE10-M10	13,8	20,0	11,5	9,5	59,0	10,5	150/50				
12		ANE10-M12	13,8	21,0	12,0	12,0	62,0	13,2	150/50				
70		6	ANE14-M6	15,8	21,0	8,0	7,0	61,0	6,4	75/25	TNN120	B15MD	
	8	ANE14-M8	15,8	21,0	9,0	8,0	63,0	8,0	75/25				
	10	ANE14-M10	15,8	21,0	11,0	10,0	67,0	10,5	75/25				
	12	ANE14-M12	15,8	22,0	14,0	12,0	72,0	13,2	75/25				
	14	ANE14-M14	15,8	25,0	16,0	14,0	76,0	15,0	100/25				
95	8	ANE19-M8	18,0	25,0	9,0	8,0	73,0	8,4	50/25	TNN120	B15MD		
	10	ANE19-M10	18,0	25,0	11,0	10,0	77,0	10,5	50/25				
	12	ANE19-M12	18,0	25,0	14,0	12,0	82,0	13,2	50/25				
	14	ANE19-M14	18,0	25,0	16,0	14,0	86,0	15,0	50/25				
	16	ANE19-M16	18,0	27,0	18,0	16,0	80,0	17,0	50/25				
120	10	ANE24-M10	20,0	28,5	11,0	10,0	77,7	10,5	50/25	TNN120	B15MD		
	12	ANE24-M12	20,0	28,5	14,0	12,0	86,5	13,2	50/25				
	14	ANE24-M14	20,0	28,5	16,0	14,0	88,5	15,0	50/25				
	16	ANE24-M16	20,0	28,5	18,0	16,0	90,5	17,0	50/25				
150	12	ANE30-M12	23,0	31,5	16,0	14,0	101,0	13,2	20/10	TNN120	B15MD		
	14	ANE30-M14	23,0	31,5	18,0	16,0	105,0	15,0	30/15				
	16	ANE30-M16	23,0	31,5	19,0	17,0	107,0	17,0	30/15				
	20	ANE30-M20	23,0	31,5	22,0	20,0	113,0	21,0	30/15				

POLYAMIDE PA6.6 INSULATED COPPER TUBE LUGS

ANE-M

for extra flexible Copper conductors

• for fine stranded •
SPECIAL
flexible conductors

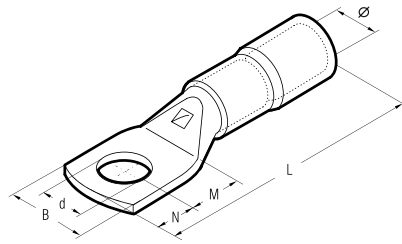

Conductor Size Extra Flexible sqmm	Ø Stud mm	Type	Dimensions mm						Quantity Box/Bag	Mechanical Tools	Hydraulic Tools				
			Ø	B	M	N	L	d							
35	6	ANE9-M6/15*	13,6	15,0	8,0	7,0	54,0	6,4	150/50	TNN70	HT51 RH50 B500ND				
	8	ANE9-M8	13,6	17,0	9,0	8,0	56,0	8,4	150/50						
	10	ANE9-M10	13,6	18,5	11,0	10,0	60,0	10,5	150/50						
	12	ANE9-M12	13,6	21,0	14,0	12,0	65,0	13,2	150/50						
50	6	ANE12-M6/15*	15,7	15,0	8,0	7,0	59,5	6,4	50/25			TNN120	HT51 RH50 B500ND		
	8	ANE12-M8	15,7	19,8	9,0	8,0	61,5	8,4	50/25						
	10	ANE12-M10	15,7	19,8	11,0	10,0	65,5	10,5	50/25						
	10	ANE12-M10/19*	15,7	19,0	11,0	10,0	65,5	10,5	50/25						
70	12	ANE12-M12	15,7	22,0	14,0	12,0	70,5	13,2	50/25					ECW-H3D	HT120 and tools and heads with 130 kN crimping force
	6	ANE17-M6	17,9	23,0	8,0	7,0	63,8	6,4	100/25						
	8	ANE17-M8	17,9	23,0	9,0	8,0	65,8	8,4	50/25						
	10	ANE17-M10	17,9	23,0	11,0	10,0	69,8	10,5	50/25						
	10	ANE17-M10/19*	17,9	19,0	11,0	10,0	69,8	10,5	100/25						
	12	ANE17-M12	17,9	23,0	14,0	12,0	74,8	13,2	50/25						
95	14	ANE17-M14	17,9	25,0	15,5	12,0	76,3	15,0	50/25	ECW-H3D	HT120 and tools and heads with 130 kN crimping force				
	16	ANE17-M16	17,9	27,0	16,5	13,5	78,8	17,0	50/25						
	8	ANE20-M8	20,0	27,0	9,0	8,0	70,6	8,4	50/25						
	10	ANE20-M10	20,0	27,0	11,0	10,0	74,6	10,5	50/25						
	12	ANE20-M12	20,0	27,0	14,0	12,0	79,6	13,2	50/25						
120	14	ANE20-M14	20,0	27,0	15,5	12,0	81,1	15,0	50/25			ECW-H3D	HT120 and tools and heads with 130 kN crimping force		
	16	ANE20-M16	20,0	27,0	16,5	13,5	83,6	17,0	50/25						
	10	ANE29-M10	22,4	30,0	11,0	10,0	81,5	10,5	30/15						
	12	ANE29-M12	22,4	30,0	14,0	12,0	86,5	13,2	30/15						
	14	ANE29-M14	22,4	30,0	15,5	12,0	88,5	15,0	50/25						
150	16	ANE29-M16	22,4	30,0	16,5	13,5	90,5	17,0	50/25					ECW-H3D	HT120 and tools and heads with 130 kN crimping force
	20	ANE29-M20	22,4	30,0	22,0	20,0	102,5	21,0	40/20						
	12	ANE35-M12	25,0	34,2	16,0	14,0	95,0	13,2	30/15						
	14	ANE35-M14	25,0	34,2	18,0	16,0	99,0	15,0	30/15						
150	16	ANE35-M16	25,0	34,2	19,0	17,0	101,0	17,0	30/15	ECW-H3D	HT120 and tools and heads with 130 kN crimping force				
	20	ANE35-M20	25,0	34,2	22,0	20,0	107,0	21,0	30/15						

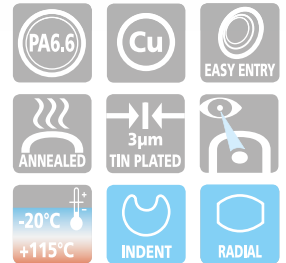

These lugs are particularly recommended for use with extra flexible conductors on for instance, welding machines.

ANE-M series lugs are manufactured from electrolytic Copper tube with a purity greater than 99.9%, annealed and Tin plated.

The interior of the PA6.6 insulated sleeve is funnel shaped so as to ensure complete and easy introduction of the conductor strands. It also eliminates the need to insulate the terminal using either tape or heat shrinkable tubing.

Furthermore the PA6.6 sleeve avoids the possibility of conductor breakage at the barrel entrance.

The operating temperature range is -20 to +115°C (Surge +130°C). In order to achieve the best electrical and mechanical performance it is suggested that they are crimped using dies and tools specifically developed for this purpose by CEMBRE.

Details of the appropriate crimping tools and dies are shown on pages 314 to 315.

AN-M IN-M EN-M

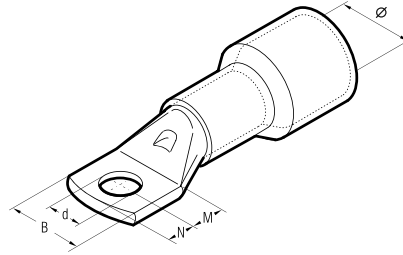

POLYAMIDE PA6.6 INSULATED COPPER TUBE LUGS

for Copper conductors

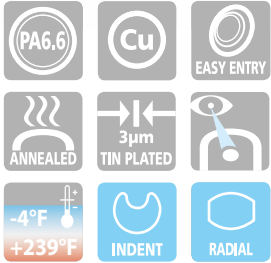

These terminals are particularly recommended for use with flexible conductors.

They are manufactured from electrolytic copper tube with a purity greater than 99.9% and with dimension so as to ensure both a good electrical connection and an adequate resistance to vibrations and traction; they are annealed and tin plated.

For the same cable section are available different types of connectors with PA6.6 sleeve entry of different diameters so as to accept conductors with various insulation thickness.

The insulated sleeve additionally will accept the conductor so avoiding a sudden bending of the conductor itself at the connector entry, highly increasing its resistance to the mechanical solicitations that could break the conductor strands.

The operating temperature range is -20 to +115°C (Surge +130°C).

- To complete the type of connectors add the screw diameter expressed in mm to the M reference.
- The M, N, and B dimensions concerning the palm are the same as the A-M connector ones.

These connectors can be used also on low stranded conductors if crimped with radial containment dies of the MN..RF-C series.

In order to achieve the best electrical and mechanical performance it is suggested that they are crimped using dies and tools specifically developed for this purpose by CEMBRE (see page 314 to 315).

Conductor Size mm ²	Type	Insulation		Mechanical Tools	Hydraulic Tools		
		Ø mm	colour				
1,5÷2,5 F	AN06-M.....	4,1	● blue	HNN3			
	IN06-M.....	5,3	● green				
	ENR06-M.....	6,0	● blue				
4÷6 F	AN06-M.....	6,9	● blue			HNN4	B15MD
	AN1-M.....	5,3	● yellow				
	IN1-M.....	6,6	○ neutral				
	ON1-M.....	7,6	● blue				
	UN1-M.....	8,7	● blue				
	EN1-M.....	14,1	● red				
10 F	AN2-M.....	8,0	● red			HNN4	B15MD
	IN2-M.....	10,8	● blue				
10 R	ENR2-M.....	12,5	● blue			HNN4	B15MD
	EN2-M.....	15,1	● red				
16 F	AN3-M.....	9,2	● blue	HNN4	B15MD		
	EN3-M.....	11,7	● blue				
16 R	IN3-M.....	16,9	● red	HNN4	B15MD		
	EN3-M.....	16,9	● red				
25 F 25 R	AN5-M.....	11,1	● yellow	TNN70 TNN71	HT51 RH50 B500ND		
	AN7-M.....	11,9	● red				
25÷35 F	EN7-M.....	13,0	● blue	TNN70 TNN71	HT51 RH50 B500ND		
	IN7-M.....	18,7	● red				
35 R	AN10-M.....	13,8	○ neutral	TNN70 TNN71	HT51 RH50 B500ND		
	IN10-M.....	15,0	● blue				
35 F	ENR10-M.....	17,3	● blue	TNN120	HT120 and tools and heads with 130 kN crimping force		
	EN10-M.....	20,2	● red				
50 F	AN14-M.....	15,8	● blue	TNN120	HT120 and tools and heads with 130 kN crimping force		
	IN14-M.....	16,9	● blue				
70 R	AN14-M.....	21,9	● red	TNN120	HT120 and tools and heads with 130 kN crimping force		
	EN14-M.....	21,9	● red				
70 F	AN19-M.....	18,0	● blue	TNN120	HT120 and tools and heads with 130 kN crimping force		
	EN19-M.....	19,6	● blue				
95 R	IN19-M.....	24,3	● red	TNN120	HT120 and tools and heads with 130 kN crimping force		
	EN19-M.....	19,6	● blue				
95 F	AN24-M.....	20,0	● red	TNN120	HT120 and tools and heads with 130 kN crimping force		
	IN24-M.....	22,2	● blue				
120 R	EN24-M.....	27,1	● red	TNN120	HT120 and tools and heads with 130 kN crimping force		
	EN24-M.....	27,1	● red				
120 F	AN30-M.....	23,0	● red	TNN120	HT120 and tools and heads with 130 kN crimping force		
	EN30-M.....	24,5	● blue				
150 R	IN30-M.....	29,0	● red	TNN120	HT120 and tools and heads with 130 kN crimping force		
	EN30-M.....	24,5	● blue				
150 F	INR37-M.....	29,0	● blue	TNN120	HT120 and tools and heads with 130 kN crimping force		
	IN37-M.....	31,6	● red				
185 R	EN48-M.....	29,4	● red	TNN120	HT120 and tools and heads with 130 kN crimping force		
	IN48-M.....	34,5	● red				
185 F	EN60-M.....	33,5	● red	TNN120	HT120 and tools and heads with 130 kN crimping force		
	IN60-M.....	38,0	● red				
240 F	EN80-M.....	37,7	● blue	TNN120	HT120 and tools and heads with 130 kN crimping force		
	IN80-M.....	41,1	● red				

R = Rigid conductor F = Flexible conductor

POLYAMIDE PA6.6 INSULATED FORK TERMINALS

for Copper conductors

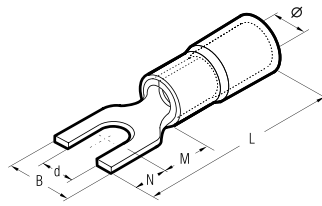

Conductor Size Flexible sqmm	Ø Stud mm	Type	Dimensions mm						Quantity Box/Bag	Mechanical Tools		Hydraulic Tools					
			Ø	B	M	N	L	d									
10	4	ANE2-U4	8,0	9,8	7,5	7,0	35,1	4,3	500/100	HNN3	HNN4	TNN70	TNN120	B15MD	HT51 RH50 B500 B500ND	HT120 and tools and heads with 130 kN crimping force	ECW-H3D
	5	ANE2-U5	8,0	11,5	7,5	7,0	35,1	5,3	500/100								
16	4	ANE3-U4	9,2	10,0	10,0	8,0	41,1	4,3	400/100	HNN3	HNN4	TNN70	TNN120	B15MD	HT51 RH50 B500 B500ND	HT120 and tools and heads with 130 kN crimping force	ECW-H3D
	5	ANE3-U5	9,2	11,5	10,0	8,0	41,1	5,3	400/100								



ANE-U series terminals are made from electrolytic Copper with a purity greater than 99.9%, rolled, Tin plated and brazed. The interior of the PA6.6 insulated sleeve is funnel shaped so as to ensure complete and easy introduction of the conductor strands. The operating temperature range is -20 to +115°C (Surge +130°C).

In order to achieve the best electrical and mechanical performance it is suggested that they are crimped using dies and tools specifically developed for this purpose by CEMBRE. Details of the appropriate crimping tools and dies are shown on pages 314 to 315.

POLYAMIDE PA6.6 INSULATED PIN TERMINALS

for Copper conductors

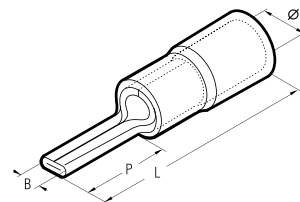

Conductor Size Flexible sqmm	Type	Dimensions mm				Quantity Box/Bag	Mechanical Tools			Hydraulic Tools				
		Ø	B	P	L									
10	ANE2-P12	8,0	4,3	14,5	35,1	500/100	HNN3	HNN4	TNN70	TNN120	B15MD	HT51 RH50 B500 B500ND	HT120 and tools and heads with 130 kN crimping force	ECW-H3D
16	ANE3-P14	9,2	5,5	18,0	41,1	400/100								
25	ANE5-P16	11,1	7,0	20,3	45,0	300/100	HNN3	HNN4	TNN70	TNN120	B15MD	HT51 RH50 B500 B500ND	HT120 and tools and heads with 130 kN crimping force	ECW-H3D
35	ANE7-P20	13,6	8,0	24,5	55,0	150/50								



ANE-P series terminals are made from electrolytic Copper with a purity greater than 99.9%, rolled, Tin plated and brazed. The interior of the PA6.6 insulated sleeve is funnel shaped so as to ensure complete and easy introduction of the conductor strands. The operating temperature range is -20 to +115°C (Surge +130°C).

In order to achieve the best electrical and mechanical performance it is suggested that they are crimped using dies and tools specifically developed for this purpose by CEMBRE. Details of the appropriate crimping tools and dies are shown on pages 314 to 315.

S

UNINSULATED TERMINALS

S range - brazed seam - for Copper conductors



S range terminals are manufactured from electrolytic Copper strip with a purity greater than 99.9% and Tin plated.

The seam is brazed to provide uniform mechanical strength. The terminal barrel is rifled to enhance electrical contact and to improve mechanical strength.

Recommended crimping tools are shown on pages 144 to 173, 260.

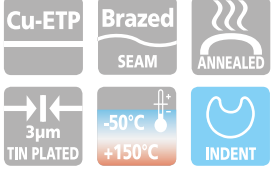

pin terminals

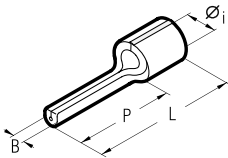

Conductor Size sqmm (AWG)	Type	Dimensions mm				Quantity Box/Bag
		Øi	B	P	L	
0,25÷1,5 [22÷16]	S1.5-P8	1,8	1,6	8,0	12,0	8.000/100
	S1.5-P10	1,8	1,6	10,0	14,0	8.000/100
	S1.5-P12	1,8	1,6	12,0	16,2	8.000/100
1,5÷2,5 [16÷14]	S2.5-P8	2,4	1,6	8,0	12,0	7.000/100
	S2.5-P10	2,4	1,6	10,0	14,0	7.000/100
	S2.5-P12	2,4	1,6	12,0	16,0	7.000/100
4÷6 [12÷10]	S6-P10	3,6	2,2	10,0	16,8	4.000/100
	S6-P12	3,6	2,2	12,0	19,0	4.000/100
	S6-P14	3,6	2,2	14,0	21,0	3.500/100

blade terminals

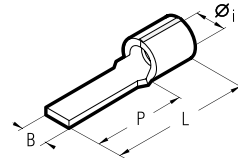

Conductor Size sqmm (AWG)	Type	Dimensions mm				Quantity Box/Bag
		Øi	B	P	L	
0,25÷1,5 [22÷16]	S1.5-PP12	1,8	3,0	12,8	17,0	8.000/100
	S1.5-PP12/1*	1,8	3,0	11,3	15,5	8.000/100
	S1.5-PP12/19	1,8	1,9	13,2	17,4	8.000/100
	S1.5-PP14	1,8	3,0	14,8	19,0	8.000/100
1,5÷2,5 [16÷14]	S2.5-PP12	2,4	3,5	12,8	17,0	7.000/100
	S2.5-PP12/25	2,4	2,5	13,3	17,5	7.000/100
	S2.5-PP16/25	2,4	2,5	17,2	21,4	7.000/100
4÷6 [12÷10]	S6-PP12	3,6	4,0	13,3	19,7	4.000/100
	S6-PP17	3,6	2,9	19,1	25,5	4.000/100

*Made to order

UNINSULATED TERMINALS

S

S range - brazed seam - for Copper conductors

ring terminals

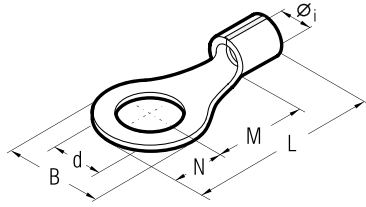

fork/spade terminals

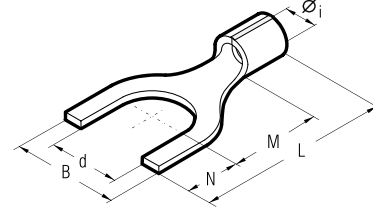

Conductor Size sqmm (AWG)	Ø Stud mm	Type	Dimensions mm						Quantity Box/Bag
			Øi	B	M	N	L	d	
0,25÷1,5 [22÷16]	2	S1.5-M2*	1,8	5,6	4,5	2,8	11,5	2,2	7.000/100
	3	S1.5-M3	1,8	5,6	4,5	2,8	11,5	3,2	7.000/100
	3,5	S1.5-M3.5	1,8	5,6	4,5	2,8	11,5	3,7	7.000/100
	3,5	S1.5-M3.5/1*	1,8	6,2	7,1	3,1	14,4	3,7	7.000/100
	4	S1.5-M4	1,8	7,0	6,5	3,5	14,2	4,3	7.000/100
	4	S1.5-M4/3*	1,8	7,8	7,1	3,9	15,2	4,3	7.000/100
	5	S1.5-M5	1,8	7,8	7,1	3,9	15,2	5,3	7.000/100
	6	S1.5-M6	1,8	9,4	8,1	4,7	17,0	6,4	6.000/100
	6	S1.5-M6/1	1,8	12,0	10,3	6,0	20,5	6,4	5.000/100
	7	S1.5-M7	1,8	9,4	8,1	4,7	17,0	7,2	6.000/100
	8	S1.5-M8	1,8	12,0	10,3	6,0	20,5	8,4	4.000/100
	10	S1.5-M10	1,8	15,5	13,0	7,7	25,0	10,5	3.000/100
12	S1.5-M12	1,8	18,0	15,5	9,0	28,7	13,0	2.000/100	
1,5÷2,5 [16÷14]	3	S2.5-M3	2,4	5,6	5,0	2,8	12,0	3,2	6.000/100
	3,5	S2.5-M3.5	2,4	5,6	5,0	2,8	12,0	3,7	6.000/100
	3,5	S2.5-M3.5/1*	2,4	6,2	6,5	3,1	13,8	3,7	5.000/100
	4	S2.5-M4	2,4	8,0	6,5	4,0	14,7	4,3	5.000/100
	5	S2.5-M5	2,4	8,0	7,5	4,0	15,7	5,3	5.000/100
	6	S2.5-M6	2,4	9,4	8,6	4,7	17,5	6,4	5.000/100
	6	S2.5-M6/1	2,4	12,0	10,3	6,0	20,5	6,4	5.000/100
	7	S2.5-M7	2,4	10,0	7,8	5,0	17,0	7,2	5.000/100
	8	S2.5-M8	2,4	12,0	10,3	6,0	20,5	8,4	4.000/100
	10	S2.5-M10	2,4	15,5	13,0	7,7	25,0	10,5	2.500/100
	12	S2.5-M12	2,4	18,0	15,5	9,0	28,7	13,0	2.000/100
	4÷6 [12÷10]	3	S6-M3	3,6	8,0	8,1	4,0	18,5	3,2
3,5		S6-M3.5	3,6	8,0	8,1	4,0	18,5	3,7	3.000/100
4		S6-M4	3,6	9,0	8,1	4,5	19,0	4,3	3.000/100
5		S6-M5	3,6	9,0	8,1	4,5	19,0	5,3	2.500/100
6		S6-M6	3,6	11,0	11,1	5,5	23,0	6,4	2.500/100
6		S6-M6/1*	3,6	11,0	8,1	5,5	20,0	6,4	2.500/100
7		S6-M7	3,6	11,0	11,1	5,5	23,0	7,2	2.500/100
8		S6-M8	3,6	13,6	12,1	6,8	25,3	8,4	2.000/100
8		S6-M8/1*	3,6	11,0	8,1	5,5	20,0	8,4	2.500/100
10		S6-M10	3,6	13,6	12,1	6,8	25,3	10,5	2.000/100
10		S6-M10/1	3,6	15,5	13,8	7,7	28,0	10,5	2.000/100
12		S6-M12	3,6	19,0	15,1	9,5	31,0	13,0	1.000/100
14	S6-M14	3,6	21,0	16,1	10,5	33,0	15,0	1.000/100	
16	S6-M16	3,6	24,0	17,1	12,0	35,5	17,0	1.000/100	
10 (8)	4	S10-M4	4,8	11,5	9,0	5,8	23,8	4,3	2.000/100
	5	S10-M5	4,8	11,5	9,0	5,8	23,8	5,3	2.000/100
	6	S10-M6	4,8	11,5	9,0	5,8	23,8	6,4	2.000/100
	7	S10-M7	4,8	11,5	9,0	5,8	23,8	7,2	1.500/100

Conductor Size sqmm (AWG)	Ø Stud mm	Type	Dimensions mm						Quantity Box/Bag
			Øi	B	M	N	L	d	
0,25÷1,5 [22÷16]	3	S1.5-U3	1,8	5,5	5,5	4,0	13,7	3,2	7.000/100
	3,5	S1.5-U3.5	1,8	6,0	6,5	3,8	14,5	3,7	7.000/100
	3,5	S1.5-U3.5/2*	1,8	6,4	6,5	3,8	14,5	3,7	7.000/100
	4	S1.5-U4	1,8	6,5	7,5	3,7	15,4	4,3	7.000/100
	4	S1.5-U4/1*	1,8	8,5	7,5	3,7	15,4	4,3	7.000/100
	4	S1.5-U4/2	1,8	7,5	7,5	3,7	15,4	4,3	7.000/100
	5	S1.5-U5	1,8	8,5	7,5	3,7	15,4	5,3	7.000/100
	5	S1.5-U5/1	1,8	9,4	7,5	3,7	15,4	5,3	7.000/100
	6	S1.5-U6	1,8	9,4	8,1	4,7	17,0	6,4	6.000/100
	6	S1.5-U6/1*	1,8	12,0	9,2	7,1	20,5	6,4	6.000/100
	8	S1.5-U8	1,8	14,0	10,0	6,3	20,5	8,4	3.000/100
	10	S1.5-U10	1,8	17,5	13,0	7,7	25,0	10,5	2.500/100
12	S1.5-U12	1,8	20,0	15,5	9,0	28,7	13,0	2.000/100	
1,5÷2,5 [16÷14]	3	S2.5-U3	2,4	5,5	5,5	4,0	13,7	3,2	6.000/100
	3,5	S2.5-U3.5	2,4	6,4	6,5	3,8	14,5	3,7	6.000/100
	3,5	S2.5-U3.5/1*	2,4	7,2	6,5	3,8	14,5	3,7	6.000/100
	4	S2.5-U4	2,4	6,5	7,5	3,7	15,4	4,3	5.000/100
	4	S2.5-U4/1*	2,4	8,5	7,5	3,7	15,4	4,3	6.000/100
	4	S2.5-U4/2*	2,4	7,5	7,5	3,7	15,4	4,3	6.000/100
	5	S2.5-U5	2,4	8,5	7,5	3,7	15,4	5,3	6.000/100
	6	S2.5-U6	2,4	9,4	8,1	4,7	17,0	6,4	5.000/100
	6	S2.5-U6/1*	2,4	12,0	9,2	7,1	20,5	6,4	4.000/100
	8	S2.5-U8	2,4	14,0	10,0	6,3	20,5	8,4	2.500/100
	10	S2.5-U10	2,4	17,5	13,0	7,7	25,0	10,5	2.000/100
	12	S2.5-U12	2,4	20,0	15,5	9,0	28,7	13,0	2.000/100
4÷6 [12÷10]	3,5	S6-U3.5	3,6	7,5	8,5	3,9	18,8	3,7	3.000/100
	4	S6-U4	3,6	7,5	8,0	4,4	18,8	4,3	3.000/100
	5	S6-U5	3,6	9,5	8,0	4,4	18,8	5,3	2.500/100
	6	S6-U6	3,6	10,0	11,0	5,5	22,9	6,4	2.500/100
	8	S6-U8	3,6	13,5	12,0	8,0	26,4	8,4	2.000/100
	10	S6-U10	3,6	15,5	13,0	8,0	27,4	10,5	2.000/100
	10	S6-U10/1*	3,6	17,5	13,8	7,7	28,0	10,5	2.000/100
	12	S6-U12	3,6	21,0	15,1	9,5	31,0	13,0	1.000/100
	14	S6-U14	3,6	23,0	16,1	10,5	33,0	15,0	1.000/100
	16	S6-U16*	3,6	26,0	17,1	11,5	35,0	17,0	1.000/100

*Made to order

RN, BN, GN range - unbraced - for Copper conductors



RN, BN, GN range terminals are manufactured from electrolytic Copper strip with a purity greater than 99.9% and Tin plated. The seam is unbraced.

The terminal barrel is rifled to enhance electrical contact and to improve mechanical strength.

Recommended crimping tools are shown on pages 144 to 173, 260.

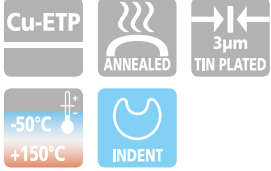

pin terminals

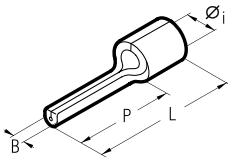

Conductor Size sqmm (AWG)	Type	Dimensions mm				Quantity Box/Bag
		Øi	B	P	L	
0,25÷1,5 [22÷16]	RN-P8	1,8	1,6	8,0	12,0	8.000/100
	RN-P10	1,8	1,6	10,0	14,0	8.000/100
	RN-P12	1,8	1,6	12,0	16,2	8.000/100
1,5÷2,5 [16÷14]	BN-P8	2,4	1,6	8,0	12,0	7.000/100
	BN-P10	2,4	1,6	10,0	14,0	7.000/100
	BN-P12	2,4	1,6	12,0	16,0	7.000/100
4÷6 [12÷10]	GN-P10	3,6	2,2	10,0	16,8	4.000/100
	GN-P12	3,6	2,2	12,0	19,0	4.000/100
	GN-P14	3,6	2,2	14,0	21,0	3.500/100

blade terminals

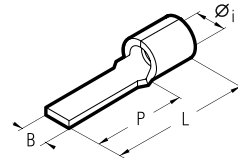

Conductor Size sqmm (AWG)	Type	Dimensions mm				Quantity Box/Bag
		Øi	B	P	L	
0,25÷1,5 [22÷16]	RN-PP12	1,8	3,0	12,8	17,0	8.000/100
	RN-PP12/1	1,8	3,0	11,3	15,5	8.000/100
	RN-PP12/19	1,8	1,9	13,2	17,4	8.000/100
	RN-PP14	1,8	3,0	14,8	19,0	8.000/100
	RN-PP16/23	1,8	2,3	17,2	21,4	8.000/100
1,5÷2,5 [16÷14]	BN-PP12	2,4	3,5	12,8	17,0	7.000/100
	BN-PP12/25	2,4	2,5	13,3	17,5	7.000/100
	BN-PP16/25	2,4	2,5	17,2	21,4	7.000/100
4÷6 [12÷10]	GN-PP12	3,6	4,0	13,3	19,7	4.000/100
	GN-PP17	3,6	2,9	19,1	25,5	3.000/100

RN, BN, GN range - unbraced - for Copper conductors

ring terminals

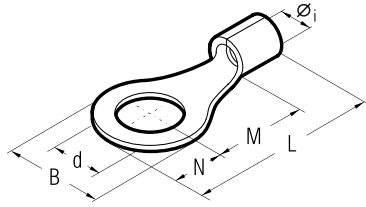

fork/spade terminals

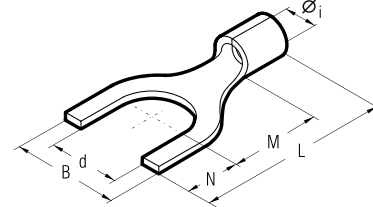

Conductor Size sqmm (AWG)	Ø Stud mm	Type	Dimensions mm					Quantity Box/Bag	
			Øi	B	M	N	L		d
0,25÷1,5 (22÷16)	2	RN-M2*	1,8	5,6	4,5	2,8	11,5	2,2	7.000/100
	3	RN-M3	1,8	5,6	4,5	2,8	11,5	3,2	7.000/100
	3,5	RN-M3.5	1,8	5,6	4,5	2,8	11,5	3,7	7.000/100
	3,5	RN-M3.5/1	1,8	6,2	7,1	3,1	14,4	3,7	7.000/100
	4	RN-M4	1,8	7,0	6,5	3,5	14,2	4,3	7.000/100
	4	RN-M4/3	1,8	7,8	7,1	3,9	15,2	4,3	7.000/100
	5	RN-M5	1,8	7,8	7,1	3,9	15,2	5,3	7.000/100
	6	RN-M6	1,8	9,4	8,1	4,7	17,0	6,4	6.000/100
	6	RN-M6/1	1,8	12,0	10,3	6,0	20,5	6,4	4.000/100
	7	RN-M7	1,8	9,4	8,1	4,7	17,0	7,2	6.000/100
	8	RN-M8	1,8	12,0	10,3	6,0	20,5	8,4	4.000/100
	10	RN-M10	1,8	15,5	13,0	7,7	25,0	10,5	2.000/100
12	RN-M12	1,8	18,0	15,5	9,0	28,7	13,0	2.000/100	
1,5÷2,5 (16÷14)	2	BN-M2*	2,4	5,6	5,0	2,8	12,0	2,2	6.000/100
	3	BN-M3	2,4	5,6	5,0	2,8	12,0	3,2	6.000/100
	3,5	BN-M3.5	2,4	5,6	5,0	2,8	12,0	3,7	6.000/100
	3,5	BN-M3.5/1	2,4	6,2	6,5	3,1	13,8	3,7	6.000/100
	4	BN-M4	2,4	8,0	6,5	4,0	14,7	4,3	5.000/100
	5	BN-M5	2,4	8,0	7,5	4,0	15,7	5,3	5.000/100
	6	BN-M6	2,4	9,4	8,6	4,7	17,5	6,4	5.000/100
	6	BN-M6/1	2,4	12,0	10,3	6,0	20,5	6,4	5.000/100
	7	BN-M7	2,4	10,0	7,8	5,0	17,0	7,2	5.000/100
	8	BN-M8	2,4	12,0	10,3	6,0	20,5	8,4	4.000/100
	10	BN-M10	2,4	15,5	13,0	7,7	25,0	10,5	2.500/100
	12	BN-M12	2,4	18,0	15,5	9,0	28,7	13,0	2.000/100
4÷6 (12÷10)	3	GN-M3	3,6	8,0	8,1	4,0	18,5	3,2	3.000/100
	3,5	GN-M3.5	3,6	8,0	8,1	4,0	18,5	3,7	3.000/100
	4	GN-M4	3,6	9,0	8,1	4,5	19,0	4,3	3.000/100
	5	GN-M5	3,6	9,0	8,1	4,5	19,0	5,3	2.500/100
	6	GN-M6	3,6	11,0	11,1	5,5	23,0	6,4	2.500/100
	6	GN-M6/1	3,6	11,0	8,1	5,5	20,0	6,4	2.500/100
	7	GN-M7	3,6	11,0	11,1	5,5	23,0	7,2	2.500/100
	8	GN-M8	3,6	13,6	12,1	6,8	25,3	8,4	2.000/100
	8	GN-M8/1*	3,6	11,0	8,1	5,5	20,0	8,4	2.500/100
	10	GN-M10	3,6	13,6	12,1	6,8	25,3	10,5	2.000/100
	10	GN-M10/1	3,6	15,5	13,8	7,7	28,0	10,5	2.000/100
	12	GN-M12	3,6	19,0	15,1	9,5	31,0	13,0	1.000/100
14	GN-M14	3,6	21,0	16,1	10,5	33,0	15,0	1.000/100	
16	GN-M16	3,6	24,0	17,1	12,0	35,5	17,0	1.000/100	

Conductor Size sqmm (AWG)	Ø Stud mm	Type	Dimensions mm					Quantity Box/Bag	
			Øi	B	M	N	L		d
0,25÷1,5 (22÷16)	3	RN-U3	1,8	5,5	5,5	4,0	13,7	3,2	7.000/100
	3,5	RN-U3.5	1,8	6,0	6,5	3,8	14,5	3,7	7.000/100
	3,5	RN-U3.5/2	1,8	6,4	6,5	3,8	14,5	3,7	7.000/100
	4	RN-U4	1,8	6,5	7,5	3,7	15,4	4,3	7.000/100
	4	RN-U4/1	1,8	8,5	7,5	3,7	15,4	4,3	7.000/100
	4	RN-U4/2	1,8	7,5	7,5	3,7	15,4	4,3	7.000/100
	5	RN-U5	1,8	8,5	7,5	3,7	15,4	5,3	5.000/100
	5	RN-U5/1*	1,8	9,4	7,5	3,7	15,4	5,3	5.000/100
	6	RN-U6	1,8	9,4	8,1	4,7	17,0	6,4	6.000/100
	6	RN-U6/1	1,8	12,0	9,2	7,1	20,5	6,4	3.000/100
	8	RN-U8	1,8	14,0	10,0	6,3	20,5	8,4	2.500/100
	10	RN-U10	1,8	17,5	13,0	7,7	25,0	10,5	2.000/100
12	RN-U12	1,8	20,0	15,5	9,0	28,7	13,0	2.000/100	
1,5÷2,5 (16÷14)	3	BN-U3	2,4	5,5	5,5	4,0	13,7	3,2	6.000/100
	3,5	BN-U3.5	2,4	6,4	6,5	3,8	14,5	3,7	6.000/100
	3,5	BN-U3.5/1*	2,4	7,2	6,5	3,8	14,5	3,7	6.000/100
	4	BN-U4	2,4	6,5	7,5	3,7	15,4	4,3	6.000/100
	4	BN-U4/1	2,4	8,5	7,5	3,7	15,4	4,3	6.000/100
	4	BN-U4/2	2,4	7,5	7,5	3,7	15,4	4,3	6.000/100
	5	BN-U5	2,4	8,5	7,5	3,7	15,4	5,3	5.000/100
	6	BN-U6	2,4	9,4	8,1	4,7	17,0	6,4	5.000/100
	6	BN-U6/1	2,4	12,0	9,2	7,1	20,5	6,4	4.000/100
	8	BN-U8	2,4	14,0	10,0	6,3	20,5	8,4	4.000/100
	10	BN-U10	2,4	17,5	13,0	7,7	25,0	10,5	2.000/100
	12	BN-U12	2,4	20,0	15,5	9,0	28,7	13,0	2.000/100
4÷6 (12÷10)	3,5	GN-U3.5	3,6	7,5	8,5	3,9	18,8	3,7	3.000/100
	4	GN-U4	3,6	7,5	8,0	4,4	18,8	4,3	3.000/100
	5	GN-U5	3,6	9,5	8,0	4,4	18,8	5,3	2.500/100
	6	GN-U6	3,6	10,0	11,0	5,5	22,9	6,4	2.500/100
	8	GN-U8	3,6	13,5	12,0	8,0	26,4	8,4	2.000/100
	10	GN-U10	3,6	15,5	13,0	8,0	27,4	10,5	2.000/100
	10	GN-U10/1	3,6	17,5	13,8	7,7	28,0	10,5	2.000/100
	12	GN-U12	3,6	21,0	15,1	9,5	31,0	13,0	1.000/100
	14	GN-U14	3,6	23,0	16,1	10,5	33,0	15,0	1.000/100
	16	GN-U16	3,6	26,0	17,1	11,5	35,0	17,0	1.000/100

*Made to order



CRIMPING CONNECTORS ACCORDING TO DIN 46234

for Copper conductors

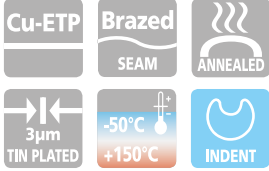
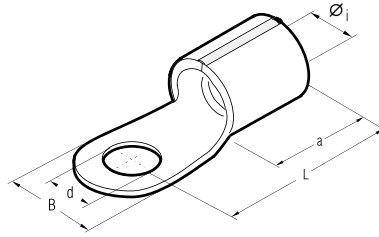

Q type connectors are manufactured from electrolytic Copper strip with a purity greater than 99.9%, annealed and surface protected by tin plating; dimensions are compliant with DIN 46234; the sleeve is brazed with a silver-Copper alloy.

Details of the conductor csa and stud diameter are engraved on the palm.

Details of the appropriate crimping tools and dies are shown on page 320.

Consult us for special requirements.

Conductor Size sqmm	Ø Stud mm	Type	Dimensions mm					Quantity Box/Bag	Mechanical Tools	Hydraulic Tools				
			Øi	d	L	B	a							
6÷10	4	Q10-4	4,5	4,3	16,0	10,0	8,0	1.500/100	HNS*	RHU81D	RHU81D	RH60C B600C B600CND	HT120 and tools and heads with 130 kN crimping force	ECW-H3D
	5	Q10-5	4,5	5,3	16,0	10,0	8,0	1.500/100						
	6	Q10-6	4,5	6,5	17,0	11,0	8,0	1.000/100						
	8	Q10-8	4,5	8,4	20,0	14,0	8,0	1.000/100						
	10	Q10-10	4,5	10,5	21,0	18,0	8,0	1.000/100						
10÷16	12	Q10-12	4,5	13,0	22,0	22,0	8,0	500/100						
	5	Q16-5	5,8	5,3	20,0	11,0	10,0	1.000/100						
	6	Q16-6	5,8	6,5	20,0	11,0	10,0	1.000/100						
	8	Q16-8	5,8	8,4	22,0	14,0	10,0	500/100						
16÷25	10	Q16-10	5,8	10,5	24,0	18,0	10,0	500/100						
	12	Q16-12	5,8	13,0	26,0	22,0	10,0	500/100						
	5	Q25-5	7,5	5,3	25,0	12,0	11,0	500/100						
	6	Q25-6	7,5	6,5	25,0	12,0	11,0	500/100						
	8	Q25-8	7,5	8,4	25,0	16,0	11,0	500/100						
25÷35	10	Q25-10	7,5	10,5	26,0	18,0	11,0	500/100						
	12	Q25-12	7,5	13,0	31,0	22,0	11,0	500/100						
	16	Q25-16	7,5	17,0	35,0	28,0	11,0	200/100						
	6	Q35-6	9,0	6,5	26,0	15,0	12,0	400/100						
	8	Q35-8	9,0	8,4	26,0	16,0	12,0	400/100						
35÷50	10	Q35-10	9,0	10,5	27,0	18,0	12,0	300/100						
	12	Q35-12	9,0	13,0	31,0	22,0	12,0	250/50						
	16	Q35-16	9,0	17,0	36,0	28,0	12,0	200/50						
	6	Q50-6	11,0	6,5	34,0	18,0	16,0	200/50						
	8	Q50-8	11,0	8,4	34,0	18,0	16,0	200/50						
50÷70	10	Q50-10	11,0	10,5	34,0	18,0	16,0	200/50						
	12	Q50-12	11,0	13,0	36,0	22,0	16,0	200/50						
	16	Q50-16	11,0	17,0	40,0	28,0	16,0	200/50						
	6	Q70-6	13,0	6,5	38,0	22,0	18,0	100/50						
70÷95	8	Q70-8	13,0	8,4	38,0	22,0	18,0	100/50						
	10	Q70-10	13,0	10,5	38,0	22,0	18,0	100/50						
	12	Q70-12	13,0	13,0	38,0	22,0	18,0	100/50						
	16	Q70-16	13,0	17,0	42,0	28,0	18,0	100/50						
70÷95	8	Q95-8	15,0	8,4	42,0	24,0	20,0	100/25						
	10	Q95-10	15,0	10,5	42,0	24,0	20,0	100/25						
	12	Q95-12	15,0	13,0	44,0	24,0	20,0	100/25						
	16	Q95-16	15,0	17,0	70,0	28,0	20,0	100/25						

CRIMPING CONNECTORS ACCORDING TO DIN 46234

for Copper conductors

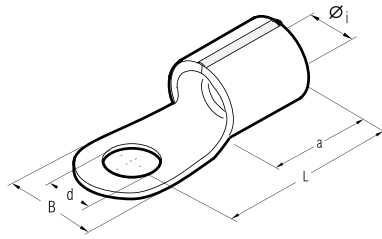

Conductor Size sqmm	Ø Stud mm	Type	Dimensions mm					Quantity Box/Bag	Hydraulic Tools	
			Øi	d	L	B	a		HT120 and tools and heads with 130 kN crimping force	ECW-H3D
95÷120	8	Q120-8	16,5	8,4	44,0	24,0	22,0	100/25		
	10	Q120-10	16,5	10,5	44,0	24,0	22,0	100/25		
	12	Q120-12	16,5	13,0	44,0	24,0	22,0	100/25		
	16	Q120-16	16,5	17,0	48,0	28,0	22,0	50/25		
120:150	10	Q150-10	19,0	10,5	50,0	30,0	24,0	50/25		
	12	Q150-12	19,0	13,0	50,0	30,0	24,0	50/25		
	16	Q150-16	19,0	17,0	50,0	30,0	24,0	50/25		
150÷185	10	Q185-10	21,0	10,5	50,0	36,0	28,0	40/20		
	12	Q185-12	21,0	13,0	50,0	36,0	28,0	40/20		
	16	Q185-16	21,0	17,0	50,0	36,0	28,0	30/15		
185÷240	10	Q240-10	23,5	10,5	56,0	38,0	32,0	10/10		
	12	Q240-12	23,5	13,0	56,0	38,0	32,0	10/10		
	16	Q240-16	23,5	17,0	56,0	38,0	32,0	10/10		

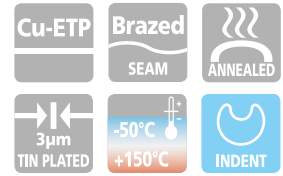

Consult us for special requirements.

Consult us for further information.

A-M

COPPER TUBE CRIMPING LUGS

for Copper conductors

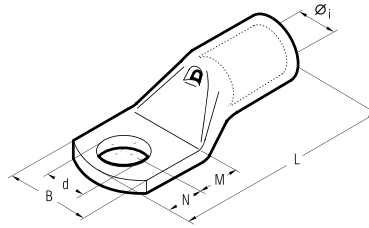

A-M series lugs are manufactured from electrolytic Copper tube with a purity greater than 99.9%.

The dimensions of the tube are designed to obtain the most efficient electrical conductivity and mechanical strength to resist vibration and pull out.

CEMBRE lugs are annealed to guarantee optimum ductility which is an absolute necessity for connectors which will have to withstand the severe deformation arising when compressed and any bending of the palm during installation. In applications subject to vibration, lugs still have to provide a reliable connection and annealing plays a vital role in avoiding cracking or breaks between the barrel and palm.

The presence of an inspection hole facilitates full insertion of the conductor, whilst the barrel length has been designed to allow easy and accurate positioning of the dies during the crimping operation.

Lugs are electrolytically Tin plated to avoid oxidation. A-M series lugs form an important part of CEMBRE crimping systems for power carrying conductors, details of the appropriate crimping tools and dies are shown opposite and in detail on pages 312 to 313.

Our technicians are always available to provide any technical advice which may be required.

The enclosed table is only indicative of the range and many variations in stud fixing and palm lengths are also available.

Conductor Size sqmm	Ø Stud mm	Type	Dimensions mm						Quantity Box/Bag	Mechanical Tools	Hydraulic Tools
			Øi	B	M	N	L	d			
0,25÷1,5	3	A03-M3*	1,8	6,0	4,5	3,5	16,0	3,2	5.000/100	HN1	B15MD
	3,5	A03-M3.5*	1,8	6,5	4,5	3,5	16,0	3,7	5.000/100		
	4	A03-M4*	1,8	6,5	5,0	4,0	17,0	4,3	5.000/100		
	5	A03-M5*	1,8	7,5	5,5	4,5	18,0	5,3	5.000/100		
	6	A03-M6*	1,8	9,0	6,0	5,0	19,0	6,4	5.000/100		
	3	A06-M3*	2,4	6,0	4,5	3,5	17,0	3,2	4.000/100		
1,5÷2,5	3,5	A06-M3.5*	2,4	6,5	4,5	3,5	17,0	3,7	4.000/100	HN5	B15MD
	4	A06-M4*	2,4	7,5	5,0	4,0	18,0	4,3	4.000/100		
	5	A06-M5*	2,4	8,5	5,5	4,5	19,0	5,3	4.000/100		
	6	A06-M6*	2,4	9,0	6,0	5,0	20,0	6,4	4.000/100		
	8	A06-M8*	2,4	12,0	9,0	8,0	26,0	8,4	2.500/100		
	3	A1-M3	3,6	7,5	4,5	3,5	20,5	3,2	2.000/100		
3,5	A1-M3.5	3,6	7,5	4,5	3,5	20,5	3,7	2.000/100			
4	A1-M4	3,6	8,0	5,0	4,0	21,5	4,3	2.000/100			
5	A1-M5	3,6	9,0	6,5	6,0	25,0	5,3	2.000/100			
6	A1-M6	3,6	11,0	7,0	6,0	25,5	6,4	1.500/100			
8	A1-M8	3,6	14,0	9,0	8,0	29,5	8,4	1.500/100			
4÷6	10	A1-M10	3,6	16,5	11,0	10,0	34,0	10,5	1.000/100	HN5	B15MD
	4	A2-M4	4,6	10,0	5,0	4,0	22,5	4,3	1.500/100		
	5	A2-M5	4,6	10,0	6,5	6,0	26,0	5,3	1.000/100		
	6	A2-M6	4,6	11,0	7,0	6,0	26,5	6,4	1.000/100		
	8	A2-M8	4,6	15,0	9,0	8,0	30,5	8,4	1.000/100		
	10	A2-M10	4,6	18,0	11,0	10,0	34,5	10,5	500/100		
10	12	A2-M12	4,6	19,0	14,0	12,0	39,5	13,2	500/100	HN425	B15MD
	4	A3-M4	5,8	11,5	5,0	4,0	25,5	4,3	1.000/100		
	5	A3-M5	5,8	11,5	6,5	6,0	29,0	5,3	1.000/100		
	6	A3-M6	5,8	11,5	7,0	6,0	29,5	6,4	1.000/100		
	8	A3-M8	5,8	15,0	9,0	8,0	33,5	8,4	500/100		
	10	A3-M10	5,8	18,0	11,0	10,0	37,5	10,5	500/100		
16	12	A3-M12	5,8	20,0	14,0	12,0	44,0	13,2	500/100	TN70SE	B15MD
	4	A5-M4	7,0	14,0	5,0	4,0	28,0	4,3	500/100		
	5	A5-M5	7,0	14,0	6,5	6,0	31,5	5,3	500/100		
	6	A5-M6	7,0	14,0	7,0	6,0	32,0	6,4	500/100		
	8	A5-M8	7,0	15,0	9,0	8,0	36,0	8,4	500/100		
	10	A5-M10	7,0	18,0	11,0	10,0	40,0	10,5	500/100		
25	12	A5-M12	7,0	21,0	14,0	12,0	45,0	13,2	400/100	TN120SE	B15MD
	5	A7-M5	8,9	17,0	6,5	6,0	34,0	5,3	400/100		
	6	A7-M6	8,9	17,0	7,0	6,0	34,5	6,4	400/100		
	8	A7-M8	8,9	17,0	9,0	8,0	38,5	8,4	400/100		
	10	A7-M10	8,9	19,0	11,0	10,0	42,5	10,5	300/100		
	12	A7-M12	8,9	21,0	14,0	12,0	47,5	13,2	200/50		
35	6	A10-M6	10,0	19,0	8,0	7,0	38,5	6,4	200/50	TN120SE	B15MD
	8	A10-M8	10,0	19,0	9,0	8,0	40,5	8,4	200/50		
	10	A10-M10	10,0	20,0	11,5	9,5	44,5	10,5	200/50		
	12	A10-M12	10,0	21,0	12,0	12,0	47,5	13,2	200/50		
	14	A10-M14	10,0	25,0	16,0	14,0	55,5	15,0	200/50		
	16	A10-M16	10,0	26,0	18,0	16,0	59,5	17,0	100/50		
50	6	A14-M6	11,3	21,0	8,0	7,0	44,0	6,4	200/50	TN120SE	B15MD
	8	A14-M8	11,3	21,0	9,0	8,0	46,0	8,4	200/50		
	10	A14-M10	11,3	21,0	11,0	10,0	50,0	10,5	200/50		
	12	A14-M12	11,3	22,0	14,0	12,0	55,0	13,2	150/50		
	14	A14-M14	11,3	25,0	16,0	14,0	59,0	15,0	100/50		
	16	A14-M16	11,3	26,0	18,0	16,0	63,0	17,0	100/50		
70	6	A14-M6	11,3	21,0	8,0	7,0	44,0	6,4	200/50	TN120SE	B15MD
	8	A14-M8	11,3	21,0	9,0	8,0	46,0	8,4	200/50		
	10	A14-M10	11,3	21,0	11,0	10,0	50,0	10,5	200/50		
	12	A14-M12	11,3	22,0	14,0	12,0	55,0	13,2	150/50		
	14	A14-M14	11,3	25,0	16,0	14,0	59,0	15,0	100/50		
	16	A14-M16	11,3	26,0	18,0	16,0	63,0	17,0	100/50		

*Not UL approved

COPPER TUBE CRIMPING LUGS

for Copper conductors

A-M

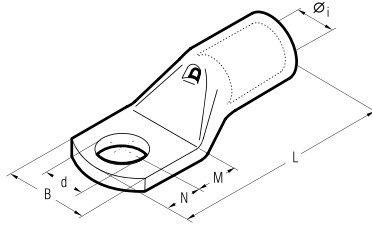

Conductor Size sqmm		Type	Dimensions mm							Quantity Box/Bag	Mechanical Tools	Hydraulic Tools	
Low Str.	Flex*		Øi	B	M	N	L	d					
95	70 95	6 A19-M6	13,5	25,0	8,0	7,0	50,5	6,4	100/25	TNI20SE** HT45-E B450ND-BV	HT51	RH50 B500ND RH60C HT60C B600CND RH81-U RHU81	HT120 and tools and heads with 130 kN crimping force ECW-H3D RHU520
		8 A19-M8	13,5	25,0	9,0	8,0	52,5	8,4	100/25				
		10 A19-M10	13,5	25,0	11,0	10,0	56,5	10,5	100/25				
		12 A19-M12	13,5	25,0	14,0	12,0	61,5	13,2	100/25				
		14 A19-M14	13,5	25,0	16,0	14,0	65,5	15,0	100/25				
		16 A19-M16	13,5	27,0	18,0	16,0	69,5	17,0	50/25				
		20 A19-M20	13,5	29,5	22,0	20,0	77,5	21,0	50/25				
120	95 120	8 A24-M8	15,2	28,5	9,0	8,0	54,0	8,4	75/25				
		10 A24-M10	15,2	28,5	11,0	10,0	58,0	10,5	75/25				
		12 A24-M12	15,2	28,5	14,0	12,0	63,0	13,2	75/25				
		14 A24-M14	15,2	28,5	16,0	14,0	67,0	15,0	50/25				
		16 A24-M16	15,2	28,5	18,0	16,0	71,0	17,0	50/25				
		20 A24-M20	15,2	30,0	22,0	20,0	79,0	21,0	50/25				
150	120 150	8 A30-M8	16,7	31,5	13,0	11,0	69,0	8,4	50/25				
		10 A30-M10	16,7	31,5	13,0	11,0	69,0	10,5	50/25				
		12 A30-M12	16,7	31,5	16,0	14,0	75,0	13,2	50/25				
		14 A30-M14	16,7	31,5	18,0	16,0	79,0	15,0	50/25				
		16 A30-M16	16,7	31,5	19,0	17,0	81,0	17,0	50/25				
		20 A30-M20	16,7	31,5	22,0	20,0	87,0	21,0	50/25				
185	150 185	8 A37-M8	19,2	35,5	13,0	11,0	76,0	8,4	30/15				
		10 A37-M10	19,2	35,5	13,0	11,0	76,0	10,5	30/15				
		12 A37-M12	19,2	35,5	16,0	14,0	82,0	13,2	30/15				
		14 A37-M14	19,2	35,5	18,0	16,0	86,0	15,0	30/15				
		16 A37-M16	19,2	35,5	19,0	17,0	88,0	17,0	30/15				
		20 A37-M20	19,2	35,5	22,0	20,0	94,0	21,0	30/15				
240	185 240	8 A48-M8	21,1	39,0	13,0	11,0	77,5	8,4	20/10				
		10 A48-M10	21,1	39,0	13,0	11,0	77,5	10,5	20/10				
		12 A48-M12	21,1	39,0	14,0	12,0	79,5	13,2	20/10				
		14 A48-M14	21,1	39,0	18,0	16,0	92,0	15,0	20/10				
		16 A48-M16	21,1	39,0	19,0	17,0	94,0	17,0	20/10				
		20 A48-M20	21,1	39,0	22,0	20,0	100,0	21,0	20/10				
300	240 300	10 A60-M10	23,7	44,0	20,0	11,0	96,0	10,5	20/10				
		12 A60-M12	23,7	44,0	20,0	14,0	99,0	13,2	20/10				
		14 A60-M14	23,7	44,0	22,0	16,0	103,0	15,0	20/10				
		16 A60-M16	23,7	44,0	22,0	19,0	106,0	17,0	20/10				
		20 A60-M20	23,7	44,0	24,0	23,0	112,0	21,0	20/10				
400	300 400	12 A80-M12	27,0	51,0	22,0	19,0	113,0	13,2	15/5				
		14 A80-M14	27,0	51,0	22,0	19,0	113,0	15,0	15/5				
		16 A80-M16	27,0	51,0	22,0	19,0	113,0	17,0	15/5				
		20 A80-M20	27,0	51,0	24,0	23,0	119,0	21,0	15/5				
500	400 500	16 A100-M16	30,3	56,5	22,0	19,0	117,0	17,0	10/1				
		20 A100-M20	30,3	56,5	24,0	23,0	123,0	21,0	10/1				
630	500 630	16 A120-M16*	33,4	61,6	22,0	19,0	128,0	17,0	9/1				
		20 A120-M20*	33,4	61,6	24,0	23,0	134,0	21,0	9/1				
800	630	16 A160-M16*	38,0	72,0	24,0	19,0	141,0	17,0	5/1				
		20 A160-M20*	38,0	72,0	24,0	23,0	145,0	21,0	6/1				
1000	800	16 A200-M16*	44,0	80,0	24,0	19,0	158,0	17,0	5/1				
		20 A200-M20*	44,0	80,0	24,0	23,0	162,0	21,0	5/1				

*Actual conductor section may require a larger lug eg for 120mm² size use A30-... lug.

**See page 161

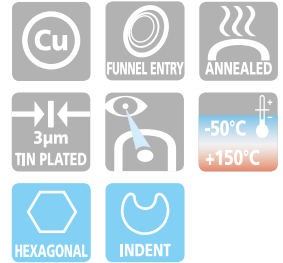

*Not UL approved

for L.V. circuit breakers - for Copper conductors

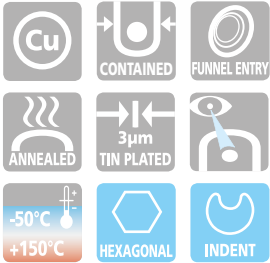
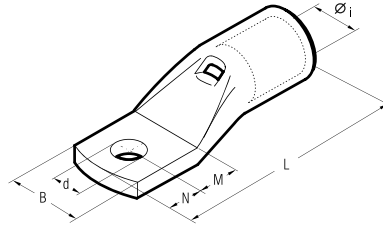

Cond. Size Flexible sqmm	Ø Stud mm	Type	Dimensions mm						Quantity Box/Bag	Mechanical Tools	Hydraulic Tools
			Øi	B	M	N	L	d			
10	5	A2-M5/9	4,6	9,0	6,5	6,0	26,0	5,3	1.000/100	HN5	B15MD
16	5	A3-M5/9	5,8	9,0	6,5	6,0	30,5	5,3	1.000/100		
25	5	A5-M5/9	7,0	9,0	6,5	6,0	31,5	5,3	500/100	HN-A25	B15MD
35	6	A7B-M6/11.5*	8,9	11,5	8,0	7,0	36,5	6,4	400/100		
50	6	A10B-M6/11.5*	10,0	11,5	8,0	7,0	40,5	6,4	200/50	TN70SE	B15MD
70	6	A14B-M6/11.5*	11,3	11,5	8,0	7,0	44,5	6,4	200/50		
95	8	A19B-M8/15.5*	13,5	15,5	9,0	8,0	52,5	8,4	100/25	TN120SE	B15MD
120	8	A24B-M8/19*	15,2	19,0	14,0	9,0	60,0	8,4	75/25		
120	10	A24B-M10/19*	15,2	19,0	14,0	9,0	60,0	10,5	75/25	HT45-E B450ND-BV	HT51
150	8	A30B-M8/19*	16,7	19,0	18,0	9,0	70,0	8,4	50/25		
150	10	A30B-M10/19*	16,7	19,0	18,0	9,0	70,0	10,5	50/25	RH50 B500 B500ND	RH60C B600C B600CND
185	10	A37B-M10/24.5*	19,2	24,5	18,0	9,0	77,0	10,5	30/15		
240	10	A48-M10/31	21,1	31,0	13,0	9,0	80,0	10,5	20/10	RH60C B600C B600CND	HT81-U RHU81
240	12	A48-M12/31	21,1	31,0	16,0	12,0	86,0	13,2	20/10		
240	16	A48-M16/31	21,1	31,0	19,0	17,0	94,0	17,0	20/10		
300	10	A60B-M10/31*	23,7	31,0	16,0	12,0	95,0	10,5	20/10	HT120 and tools and heads with 130 kN crimping force	ECW-H3D
300	12	A60B-M12/31*	23,7	31,0	16,0	12,0	95,0	13,2	20/10		

*Without inspection hole

This range of terminals features contained palm width and has been specifically developed for application on L.V. circuit breakers with reduced space terminal blocks.

The contained palm width allows an immediate and easier installation.

CEMBRE terminals are manufactured from electrolytic Copper tube with a purity greater than 99.9%.

The specifically designed section of the barrel and the choice of principal dimensions are optimising the best combination of mechanical strength and electrical conductivity.

These terminals are annealed to

guarantee optimum ductility and are electrolytically Tin plated to avoid oxidation.

The barrel is provided with an internal taper to ease the introduction of the conductor; furthermore, its length grants a comfortable and correct positioning between dies, during crimping operations.

Each palm is marked with the CEMBRE logo and part number.

Details of the appropriate crimping tools and dies are shown on pages 312 to 313.



COPPER TUBE CRIMPING LUGS

for extra flexible Copper conductors

A-M

for fine stranded
flexible conductors
SPECIAL

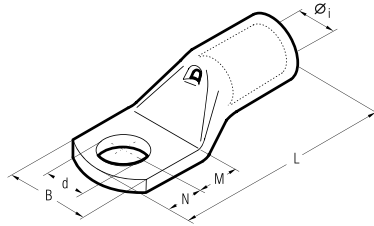

Conductor Size Extra Flexible sqmm	Ø Stud mm	Type	Dimensions mm						Quantity Box/Bag	Mechanical Tools	Hydraulic Tools		
			Øi	B	M	N	L	d					
35	6	A9-M6/15	9,3	15,0	8,0	7,0	38,5	6,4	400/100	TN70SE TN120SE	HT45-E B450ND-BV	HT51 RH50 B500 B500ND RH60C HT60C B600C B600CND HT81-U RHU81	HT120 and tools and heads with 130kN crimping force ECW-H3D RHU520
	8	A9-M8	9,3	17,0	9,0	8,0	40,5	8,4	400/100				
	10	A9-M10	9,3	18,5	11,0	10,0	44,5	10,5	300/100				
	12	A9-M12	9,3	21,0	14,0	12,0	49,5	13,2	200/50				
50	6	A12-M6/15	11,0	15,0	8,0	7,0	40,5	6,4	200/50				
	8	A12-M8	11,0	19,3	9,0	8,0	42,5	8,4	200/50				
	10	A12-M10	11,0	19,3	11,0	10,0	46,5	10,5	200/50				
	10	A12-M10/19	11,0	19,0	11,0	10,0	46,5	10,5	200/50				
	12	A12-M12	11,0	22,0	14,0	12,0	51,5	13,2	200/50				
70	6	A17-M6	13,0	23,0	8,0	7,0	45,0	6,4	200/50				
	8	A17-M8	13,0	23,0	9,0	8,0	47,0	8,4	150/50				
	10	A17-M10	13,0	23,0	11,0	10,0	51,0	10,5	150/50				
	10	A17-M10/19	13,0	19,0	11,0	10,0	51,0	10,5	200/50				
	12	A17-M12	13,0	23,0	14,0	12,0	56,0	13,2	150/50				
	14	A17-M14	13,0	25,0	15,5	12,0	57,5	15,0	150/25				
95	16	A17-M16	13,0	27,0	16,5	13,5	60,0	17,0	100/25				
	8	A20-M8	15,0	27,0	9,0	8,0	50,0	8,4	100/25				
	10	A20-M10	15,0	27,0	11,0	10,0	54,0	10,5	100/25				
	12	A20-M12	15,0	27,0	14,0	12,0	59,0	13,2	100/25				
	14	A20-M14	15,0	27,0	15,5	12,0	60,5	15,0	100/25				
120	16	A20-M16	15,0	27,0	16,5	13,5	63,0	17,0	100/25				
	8	A29-M8	16,5	30,0	9,0	8,0	53,5	8,4	100/25				
	10	A29-M10	16,5	30,0	11,0	10,0	57,5	10,5	50/25				
	12	A29-M12	16,5	30,0	14,0	12,0	62,5	13,2	50/25				
	14	A29-M14	16,5	30,0	15,5	12,0	64,0	15,0	100/25				
	16	A29-M16	16,5	30,0	16,5	13,5	66,5	17,0	100/25				
150	20	A29-M20	16,5	30,0	22,0	20,0	78,5	21,0	75/25				
	10	A35-M10	19,2	34,2	13,0	11,0	65,5	10,5	50/25				
	12	A35-M12	19,2	34,2	16,0	14,0	71,5	13,2	50/25				
	14	A35-M14	19,2	34,2	18,0	16,0	75,5	15,0	50/25				
	16	A35-M16	19,2	34,2	19,0	17,0	77,5	17,0	30/15				
185	20	A35-M20	19,2	34,2	22,0	20,0	83,5	21,0	30/15				
	10	A40-M10	21,0	37,5	13,0	11,0	73,0	10,5	30/15				
	12	A40-M12	21,0	37,5	16,0	14,0	79,0	13,2	30/15				
	14	A40-M14	21,0	37,5	18,0	16,0	83,0	15,0	30/15				
185	16	A40-M16	21,0	37,5	19,0	17,0	85,0	17,0	30/15				
	20	A40-M20	21,0	37,5	22,0	20,0	91,0	21,0	30/15				

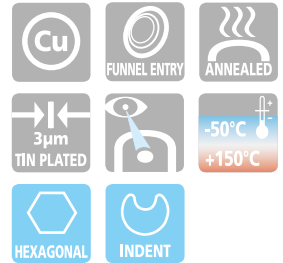

These lugs are particularly recommended for use with extra flexible conductors on for instance, welding machines.

A-M series lugs are designed to suit panel applications.

The dimensions of the tube are designed to obtain the most efficient electrical conductivity and mechanical strength to resist vibration and pull out.

CEMBRE lugs are annealed to guarantee optimum ductility and electrolytically Tin plated to avoid oxidation.

The presence of an inspection hole facilitates full insertion of the conductor.

Details of the appropriate crimping tools and dies are shown on pages 312 to 313.

A-L

COPPER TUBE CRIMPING LUGS ANGLED 90°

for Copper conductors

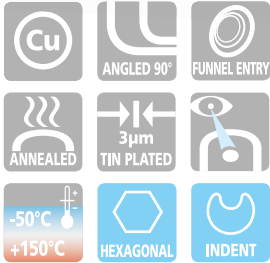
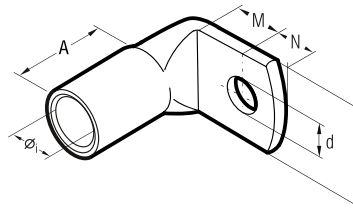

A-L series lugs angled 90° are manufactured from electrolytic Copper tube with a purity greater than 99.9%.

The dimensions of the tube are designed to obtain the most efficient electrical conductivity and mechanical strength to resist vibration and pull out.

CEMBRE lugs are annealed to guarantee optimum ductility which is an absolute necessity for connectors which will have to withstand the severe deformation arising when compressed and any bending of the palm during installation. In applications subject to vibration, terminals still have to perform a reliable connection, annealing plays a vital role in avoiding cracking or breaks between the barrel and palm.

The presence of an inspection hole facilitates full insertion of the conductor, whilst the barrel length has been designed to allow easy and accurate positioning of the dies during the crimping operation.

Lugs are electrolytically Tin plated to avoid oxidation.

Details of the appropriate crimping tools and dies are shown on pages 312 to 313.

Conductor Size sqmm	Ø Stud mm	Type	Dimensions mm						Quantity Box/Bag	Mechanical Tools		Hydraulic Tools							
			Low Str.	Flex*	Øi	B	M	N		A	d								
6	6	A1-L6*	6	6	3,6	11,0	7,0	6,0	8,0	6,4	2.000/100								
		A2-L4	6	6	4,6	10,0	5,0	4,0	8,0	4,3	1.500/100								
		A2-L5	10	6	4,6	10,0	6,5	6,0	8,0	5,3	1.000/100	HNT							
		A2-L6	10	6	4,6	11,0	7,0	6,0	8,0	6,4	1.000/100								
10	10	A2-L8	10	8	4,6	15,0	9,0	8,0	8,0	8,4	500/100								
		A3-L5	16	5	5,8	11,5	6,5	6,0	11,5	5,3	1.000/100								
		A3-L6	16	6	5,8	11,5	7,0	6,0	11,5	6,4	1.000/100	HNS							
		A3-L8	16	8	5,8	15,0	9,0	8,0	11,5	8,4	500/100								
16	16	A3-L10	16	10	5,8	18,0	11,0	10,0	11,5	10,5	500/100								
		A5-L6	25	6	7,0	14,0	7,0	6,0	10,5	6,4	500/100								
		A5-L8	25	8	7,0	15,0	9,0	8,0	10,5	8,4	500/100								
		A5-L10	25	10	7,0	18,0	11,0	10,0	10,5	10,5	500/100								
25	25	A7-L6	35	6	8,9	17,0	7,0	6,0	13,2	6,4	300/100								
		A7-L8	35	8	8,9	17,0	9,0	8,0	13,2	8,4	300/100								
		A7-L10	35	10	8,9	19,0	11,0	10,0	13,2	10,5	300/100								
		A7-L12	35	12	8,9	21,0	14,0	12,0	13,2	13,2	300/100								
35	35	A10-L6	50	6	10,0	19,0	8,0	7,0	16,5	6,4	300/100								
		A10-L8	50	8	10,0	19,0	9,0	8,0	16,5	8,4	200/100								
		A10-L10	50	10	10,0	20,0	11,5	9,5	16,5	10,5	200/50								
		A10-L12	50	12	10,0	21,0	12,0	12,0	16,5	13,2	200/50								
50	50	A14-L8	70	8	11,3	21,0	9,0	8,0	18,0	8,4	200/50								
		A14-L10	70	10	11,3	21,0	11,0	10,0	18,0	10,5	100/50								
		A14-L12	70	12	11,3	22,0	14,0	12,0	18,0	13,2	100/50								
		A14-L16	70	16	11,3	26,0	18,0	16,0	18,0	17,0	150/50								
70	70	A19-L8	95	8	13,5	25,0	9,0	8,0	22,5	8,4	100/25								
		A19-L10	95	10	13,5	25,0	11,0	10,0	22,5	10,5	100/25								
		A19-L12	95	12	13,5	25,0	14,0	12,0	22,5	13,2	100/25								
		A24-L10	120	10	15,2	28,5	11,0	10,0	24,0	10,5	50/25								
95	95	A24-L12	120	12	15,2	28,5	14,0	12,0	24,0	13,2	50/25								
		A30-L10	150	10	16,7	31,5	13,0	11,0	26,5	10,5	50/25								
		A30-L12	150	12	16,7	31,5	16,0	14,0	26,5	13,2	50/25								
		A37-L10	185	10	19,2	35,5	13,0	11,0	29,0	10,5	30/15								
120	120	A37-L12	185	12	19,2	35,5	16,0	14,0	29,0	13,2	30/25								
		A48-L10	240	10	21,1	39,0	13,0	11,0	33,0	10,5	30/15								
		A48-L12	240	12	21,1	39,0	16,0	14,0	33,0	13,2	20/10								
		A60-L12	300	12	23,7	44,0	20,0	14,0	40,0	13,2	20/10								

*Actual conductor section may require a larger lug eg for 120mm² size use A30-... lug.

**See page 161

*Not UL approved

COPPER TUBE CRIMPING LUGS

double hole fixing - for Copper conductors

A-2M

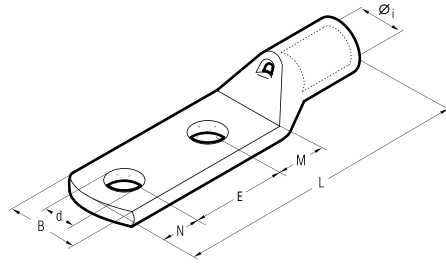

Conductor Size sqmm	Ø Stud mm	Type	Dimensions mm							Quantity Box/Bag	Mechanical Tools	Hydraulic Tools
			Øi	B	M	N	E	L	d			
10	4	A2-2M4-12	4,6	10,0	5,0	4,0	12,0	36,5	4,3	100	HN1 HN5 HN-A25	B15MD
	8	A2-2M8-20	4,6	15,0	11,0	11,0	20,0	57,5	8,4	100		
16	8	A3-2M8-20	5,8	15,0	11,0	11,0	20,0	62,0	8,4	50	HN-A25	B15MD
	12	A3-2M12-40	5,8	20,0	14,0	12,0	40,0	82,5	13,2	200/50		
25	8	A5-2M8-20	7,0	15,0	9,0	11,0	20,0	59,0	8,4	400/100	TN70SE	B15MD
	8	A5-2M8-24-24	7,0	15,0	24,0	11,0	24,0	78,0	8,4	300/100		
	10	A5-2M10-24-13	7,0	18,0	13,0	11,0	24,0	67,0	10,5	300/100		
35	10	A7-2M10	8,9	19,0	11,0	10,0	44,5	87,0	10,5	100/50	TN70SE	B15MD
	10	A7-2M10-25	8,9	19,0	12,0	11,0	25,0	69,5	10,5	100		
	12	A7-2M12	8,9	21,0	16,0	14,0	44,5	96,0	13,2	200/100		
	12	A7-2M12-25	8,9	21,0	16,0	14,0	25,0	76,5	13,2	50		
	12	A7-2M12-40	8,9	21,0	16,0	14,0	40,0	91,5	13,2	150/50		
	12	A7-2M12-40	8,9	21,0	16,0	14,0	40,0	91,5	13,2	150/50		
50	6	A10-2M6	10,0	19,0	8,0	11,0	44,5	89,0	6,4	50	TN70SE	B15MD
	8	A10-2M8	10,0	19,0	11,0	11,0	44,5	92,0	8,4	100/50		
	8	A10-2M8-20	10,0	19,0	11,0	11,0	20,0	67,5	8,4	100/50		
	8	A10-2M8-22	10,0	19,0	11,0	11,0	22,0	69,5	8,4	150/50		
	8	A10-2M8-30	10,0	19,0	11,0	11,0	30,0	77,5	8,4	150/50		
	8	A10-2M8-24-24	10,0	19,0	24,0	11,0	24,0	84,5	8,4	150/50		
	10	A10-2M10	10,0	20,0	13,0	11,0	44,5	94,0	10,5	100/50		
	10	A10-2M10-24-13	10,0	19,0	13,0	11,0	24,0	73,5	10,5	150/50		
	12	A10-2M12	10,0	21,0	16,0	14,0	44,5	100	13,2	100/50		
	12	A10-2M12-25	10,0	21,0	16,0	14,0	25,0	80,5	13,2	50		
	12	A10-2M12-40	10,0	21,0	16,0	14,0	40,0	99,0	13,2	100/50		
	70	8	A14-2M8	11,3	21,0	11,0	11,0	44,5	95,5	8,4		
8		A14-2M8-24-24	11,3	21,0	24,0	11,0	24,0	88,0	8,4	100/50		
10		A14-2M10	11,3	21,0	13,0	11,0	44,5	97,5	10,5	100/50		
10		A14-2M10-24	11,3	21,0	13,0	11,0	24,0	77,0	10,5	100/50		
12		A14-2M12	11,3	22,0	16,0	14,0	44,5	103,5	13,2	100/50		
12		A14-2M12-25	11,3	22,0	16,0	14,0	25,0	84,0	13,2	50		
12		A14-2M12-30-29	11,3	22,0	29,0	14,0	30,0	102,0	13,2	100/50		
12		A14-2M12-40	11,3	22,0	16,0	14,0	40,0	99,0	13,2	100/50		
14		A14-2M14	11,3	25,0	18,0	16,0	44,5	107,5	15,0	100/50		
14		A14-2M14	11,3	25,0	18,0	16,0	44,5	107,5	15,0	100/50		
95	6	A19-2M6	13,5	25,0	10,0	11,0	44,5	101,0	6,4	25	TN120SE	B15MD
	8	A19-2M8-50 S	13,5	25,0	15,0	15,0	50,0	115,5	8,4	75/25		
	10	A19-2M10	13,5	25,0	13,0	11,0	44,5	104,0	10,5	50/25		
	10	A19-2M10-24-13	13,5	25,0	13,0	11,0	24,0	83,5	10,5	75/25		
	10	A19-2M10-24-26	13,5	25,0	26,0	11,0	24,0	96,5	10,5	50/25		
	10	A19-2M10-40	13,5	25,0	13,0	11,0	40,0	99,5	10,5	75/25		
	12	A19-2M12	13,5	25,0	16,0	14,0	44,5	110,0	13,2	75/25		
	12	A19-2M12-25	13,5	25,0	16,0	14,0	25,0	90,5	13,2	25		
	12	A19-2M12-30-29	13,5	25,0	29,0	14,0	30,0	108,5	13,2	50/25		
	14	A19-2M14	13,5	25,0	18,0	16,0	44,5	114,0	15,0	100/25		
	14	A19-2M14-25	13,5	25,0	18,0	16,0	25,0	94,5	15,0	25		
	16	A19-2M16	13,5	25,0	19,0	17,0	44,5	116,0	17,0	50/25		
120	8	A24-2M8-20	15,2	28,5	11,0	11,0	20,0	79,0	8,4	25	TN120SE	B15MD
	8	A24-2M8-24-29	15,2	28,5	29,0	11,0	24,0	101,0	8,4	50/25		
	10	A24-2M10	15,2	28,5	13,0	11,0	44,5	105,5	10,5	50/25		
	10	A24-2M10-22	15,2	28,5	13,0	11,0	22,0	83,0	10,5	25		
	10	A24-2M10-25/24	15,2	24,0	13,0	11,0	25,0	86,0	10,5	50/25		
	10	A24-2M10-33.5	15,2	28,5	13,0	11,0	33,5	94,5	10,5	50/25		
	12	A24L-2M10-30AS	15,2	28,5	13,0	11,0	30,0	91,0	10,5	25		
	12	A24-2M12	15,2	28,5	16,0	14,0	44,5	113,0	13,2	50/25		
	12	A24-2M12-30-29	15,2	28,5	29,0	14,0	30,0	110,0	13,2	50/25		
	12	A24-2M12-40	15,2	28,5	16,0	14,0	40,0	107,0	13,2	50/25		
	14	A24-2M14	15,2	28,5	18,0	16,0	44,5	115,5	15,0	50/25		
	16	A24-2M16	15,2	28,5	19,0	17,0	44,5	117,5	17,0	50/25		

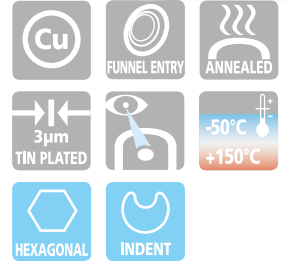

A-2M series lugs are manufactured from electrolytic copper tube with a purity greater than 99.9%. The dimensions of the tube are designed to obtain the most efficient electrical conductivity and mechanical strength to resist vibration and pull out.

The double hole fixing ensures greater mechanical stability even in the presence of electrodynamic stresses.

CEMBRE lugs are annealed to guarantee optimum ductility, an absolute necessity for connectors which will have to withstand the severe deformation arising when compressed and any bending of the palm during installation.

In applications subject to vibration, terminals still have to perform a reliable connection, annealing plays a vital role in avoiding cracking or breaks between the barrel and palm.

The presence of an inspection hole facilitates full insertion of the conductor, whilst the barrel length has been designed to allow easy and accurate positioning of the dies during the crimping operation. Lugs are electrolytically tinplated to avoid oxidation.

A-2M series lugs form an important part of CEMBRE crimping systems for power carrying conductors, details of the appropriate crimping tools and dies are shown opposite and in detail on page 312 to 313, whilst our technicians are always available to provide any technical advice which may be required.

The enclosed table is only indicative of the range and many variations in stud fixing and palm lengths are also available.

HT120 and tools and heads with 130 kN crimping force
ECW-H3D
RHU520

double hole fixing - for Copper conductors

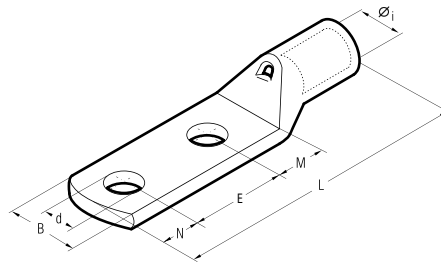

Conductor Size sqmm	Ø Stud mm	Type	Dimensions mm							Quantity Box/Bag	Mechanical Tools	Hydraulic Tools						
			Øi	B	M	N	E	L	d									
150	8	A30-2M8-20	16,7	31,5	13,0	11,0	20,0	89,0	8,4	50/25	TN120SE*	HT51	RH50 B500 B500ND	RH60C HT60C B600CND	RH81-U RHU81	HT120 and tools and heads with 130 kN crimping force	ECW-HRD	RHU520
	10	A30-2M10	16,7	31,5	13,0	11,0	44,5	113,5	10,5	50/25								
	10	A30-2M10-24-28	16,7	31,5	28,0	11,0	24,0	108,0	10,5	50/25								
	12	A30-2M12	16,7	31,5	16,0	14,0	44,5	119,5	13,2	50/25								
	12	A30-2M12-30	16,7	31,5	16,0	14,0	30,0	105,0	13,2	50/25								
	12	A30-2M12-30-29	16,7	31,5	29,0	14,0	30,0	118,0	13,2	30/15								
	12	A30-2M12-40	16,7	31,5	16,0	14,0	40,0	115,0	13,2	30/15								
	14	A30-2M14	16,7	31,5	18,0	16,0	44,5	123,5	15,0	50/25								
	14	A30-2M14-33.5	16,7	31,5	18,0	16,0	33,5	112,5	15,0	50/25								
	10	A37-2M10	19,2	35,5	13,0	11,0	44,5	120,5	10,5	30/15								
10	A37-2M10-25	19,2	35,5	13,0	11,0	25,0	101,0	10,5	30/15									
12	A37-2M12	19,2	35,5	16,0	14,0	44,5	126,5	13,2	30/15									
12	A37-2M12-32	19,2	35,5	16,0	14,0	32,0	114,0	13,2	30/15									
12	A37-2M12-30-31	19,2	35,5	31,0	14,0	30,0	127,0	13,2	30/15									
14	A37-2M14	19,2	35,5	18,0	16,0	44,5	130,5	15,0	30/15									
14	A37-2M14-35	19,2	35,5	18,0	16,0	35,0	121,0	15,0	30/15									
16	A37-2M16	19,2	35,5	19,0	17,0	44,5	132,5	17,0	30/15									
16	A37-2M16-40	19,2	35,5	19,0	17,0	40,0	128,0	17,0	30/15									
10	A48-2M10	21,1	39,0	13,0	11,0	44,5	126,5	10,5	30/15									
10	A48-2M10-20	21,1	39,0	13,0	11,0	20,0	102,0	10,5	30/15									
10	A48-2M10-35	21,1	39,0	13,0	11,0	35,0	117,0	10,5	30/15									
12	A48-2M12	21,1	39,0	16,0	14,0	44,5	132,5	13,2	30/15									
12	A48-2M12-35	21,1	39,0	16,0	14,0	35,0	123,0	13,2	30/15									
12	A48-2M12-40	21,1	39,0	16,0	14,0	40,0	128,0	13,2	30/15									
12	A48-2M12-30-31	21,1	39,0	31,0	14,0	30,0	133,0	13,2	20/10									
14	A48-2M14	21,1	39,0	18,0	16,0	44,5	136,5	15,0	30/15									
14	A48-2M14-40	21,1	39,0	18,0	16,0	40,0	132,0	15,0	30/15									
16	A48-2M16	21,1	39,0	19,0	17,0	44,5	138,5	17,0	30/15									
10	A60-2M10	23,7	44,0	13,0	11,0	44,5	133,5	10,5	20/5									
12	A60-2M12	23,7	44,0	20,0	14,0	44,5	143,5	13,2	20/5									
12	A60-2M12-40	23,7	44,0	20,0	14,0	40,0	139,0	13,2	20/5									
12	A60-2M12-30-38	23,7	44,0	38,0	14,0	30,0	147,0	13,2	20/5									
14	A60-2M14	23,7	44,0	22,0	16,0	44,5	147,5	15,0	20/5									
16	A60-2M16-40	23,7	44,0	22,0	17,0	40,0	144,0	17,0	20/5									
16	A60-2M16	23,7	44,0	22,0	17,0	44,5	148,5	17,0	20/5									
16	A60-2M16-35	23,7	44,0	22,0	17,0	35,0	139,0	17,0	20/5									
16	A60-2M16/36	23,7	36,0	22,0	17,0	44,5	148,5	17,0	20/5									
12	A80-2M12	27,0	51,0	22,0	14,0	44,5	152,5	13,2	15/5									
14	A80-2M14	27,0	51,0	22,0	16,0	44,5	154,5	15,0	15/5									
14	A80-2M14-40	27,0	51,0	22,0	16,0	40,0	150,0	15,0	15/5									
16	A80-2M16	27,0	51,0	22,0	19,0	44,5	157,5	17,0	15/5									
16	A80-2M16-40	27,0	51,0	22,0	19,0	40,0	153,0	17,0	15/5									
16	A80-2M16/41	27,0	41,0	22,0	19,0	44,5	157,5	17,0	15/5									
16	A80-2M16-50	27,0	51,0	22,0	19,0	50,0	163,0	17,0	5									
12	A100-2M12	30,3	56,5	20,0	14,0	44,5	152,0	13,2	10/1									
14	A100-2M14-40	30,3	56,5	17,0	16,0	40,0	149,0	15,0	1									
14	A100-2M14	30,3	56,5	17,0	16,0	44,5	153,5	15,0	10/1									
16	A100-2M16	30,3	56,5	19,0	19,0	44,5	158,5	17,0	10/5									
630	12	A120-2M12*	33,4	61,6	22,0	14,0	44,5	167,5	13,2	20/5								
16	A120-2M16*	33,4	61,6	22,0	19,0	44,5	172,5	17,0	8/1									
800	12	A160-2M12*	38,0	72,0	20,0	14,0	44,5	176,5	13,2	9/3								
16	A160-2M16*	38,0	72,0	22,0	19,0	44,5	183,5	17,0	9/3									

*See page 161

*Not UL approved

COPPER TUBE CRIMPING LUGS ANGLED 315° and 345°

A-2M

double hole fixing - for Copper conductors

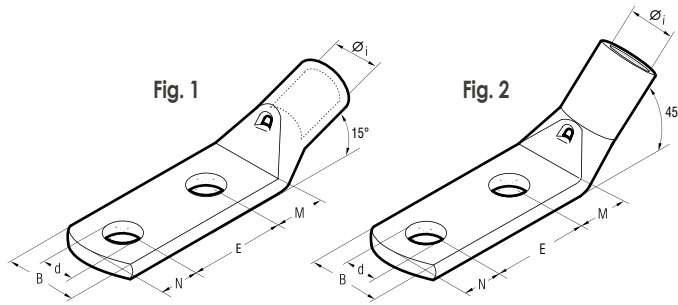

Conductor Size sqmm	Ø Stud mm	Type	Fig. N.	Dimensions mm						Quantity Box/Bag	Mechanical Tools	Hydraulic Tools
				Øi	B	M	N	E	d			
25	8	A5-2M8-24-24/345	1	7,0	15,0	24,0	11,0	24,0	8,4	300/100	HN-A25	HT45-E B450ND-BV
	12	A5-2M12-3029/345	1	7,0	21,0	29,0	14,0	30,0	13,2	200/100		
50	8	A10-2M8-2424/345	1	10,0	19,0	24,0	11,0	24,0	8,4	150/50	TN70SE	RH50 B500 B500ND RH60C HT60C B600C B600CND HT81-U RHU81
	10	A14-2M102426/315	2	11,3	21,0	26,0	11,0	24,0	10,5	100/50		
70	10	A14-2M102426/345	1	11,3	21,0	26,0	11,0	24,0	10,5	100/50	TN120SE*	HT120 and tools and heads with 130 kN crimping force ECW-H3D RHU520
	12	A14-2M123029/345	1	11,3	22,0	29,0	14,0	30,0	13,2	100/50		
95	8	A19-2M8-2424/345	1	13,5	25,0	24,0	11,0	24,0	8,4	75/25	TN120SE*	HT120 and tools and heads with 130 kN crimping force ECW-H3D RHU520
	10	A19-2M102426/345	1	13,5	25,0	26,0	11,0	24,0	10,5	25		
120	8	A24-2M8-2429/345	1	15,2	28,5	29,0	11,0	24,0	8,4	50/25	TN120SE*	HT120 and tools and heads with 130 kN crimping force ECW-H3D RHU520
	10	A24-2M102429/345	1	15,2	28,5	29,0	11,0	24,0	10,5	50/25		
150	8	A30-2M8-2429/345	1	16,7	31,5	29,0	11,0	24,0	8,4	30/15	TN120SE*	HT120 and tools and heads with 130 kN crimping force ECW-H3D RHU520
	10	A30-2M102428/345	1	16,7	31,5	28,0	11,0	24,0	10,5	50/25		
185	10	A37-2M10-25/315	2	19,2	35,5	13,0	11,0	25,0	10,5	15	TN120SE*	HT120 and tools and heads with 130 kN crimping force ECW-H3D RHU520
	12	A37-2M123031/345	1	19,2	35,5	31,0	14,0	30,0	13,2	30/15		
240	12	A48-2M12/345	1	21,1	39,0	16,0	14,0	44,5	13,2	20/10	TN120SE*	HT120 and tools and heads with 130 kN crimping force ECW-H3D RHU520
	12	A48-2M12-30/45	1	21,1	39,0	16,0	14,0	30,0	13,2	20/10		
300	12	A60-2M123038/345	1	23,7	44,0	38,0	14,0	30,0	13,2	20/10	TN120SE*	HT120 and tools and heads with 130 kN crimping force ECW-H3D RHU520

*See page 161

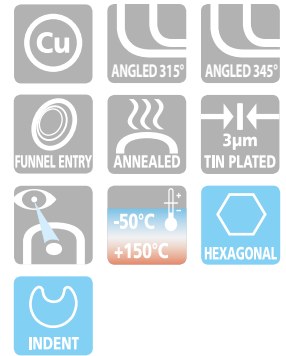

A-2M series lugs angled 315° and 345° are manufactured from electrolytic copper tube with a purity greater than 99.9%.

The dimensions of the tube are designed to obtain the most efficient electrical conductivity and mechanical strength to resist vibration and pull out.

The double hole fixing ensures greater mechanical stability even in the presence of electrodynamic stresses.

CEMBRE lugs are annealed to guarantee optimum ductility, an absolute necessity for connectors which will have to withstand the severe deformation arising when compressed and any bending of the palm during installation.

In applications subject to vibration, terminals still have to perform a reliable connection, annealing plays a vital role in avoiding cracking or breaks between the barrel and palm.

The presence of an inspection hole facilitates full insertion of the conductor, whilst the barrel length has been designed to allow easy and accurate positioning of the dies during the crimping operation. Lugs are electrolytically tinplated to avoid oxidation.

Details of the appropriate crimping tools and dies are shown on pages 312 to 313.

for Copper conductors

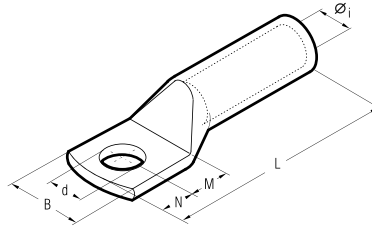

The 2A-M series cable lugs are designed for heavy duty, for grounding structures and equipment both indoors and outdoors and for medium voltage applications up to 35 kV.

2A-M series terminals are made from high purity Copper tube with a purity greater than 99.9%, and are annealed.

They feature a double length barrel for enhanced electrical and mechanical performance in heavy duty applications.

The absence of an inspection hole prevents the entry of water or moisture into the crimped joint making these terminals suitable for outdoor applications.

The terminals are electrolytically Tin plated to prevent atmospheric corrosion.

Details of the appropriate crimping tools and dies are shown on pages 312 to 313.

Conductor Size sqmm	Ø Stud mm	Type	Dimensions mm						Quantity Box/Bag	Mechanical Tools	Hydraulic Tools							
			Øi	B	M	N	L	d										
16	8	2A3-M8	5,8	15,0	9,0	8,0	43,5	8,4	600/100	HNS	HN-A25	B15MD						
	10	2A3-M10	5,8	18,0	11,0	10,0	47,5	10,5	500/100									
25	8	2A5-M8	7,0	15,0	9,0	8,0	51,0	8,4	400/100	HN-A25	B15MD							
	10	2A5-M10	7,0	18,0	11,0	10,0	55,0	10,5	300/50									
25	12	2A5-M12	7,0	21,0	14,0	12,0	60,0	13,2	300/50	HN-A25	B15MD							
	8	2A7-M8	8,9	17,0	9,0	8,0	53,0	8,4	200/50									
35	10	2A7-M10	8,9	19,0	11,0	10,0	57,0	10,5	200/50	HN-A25	B15MD							
	12	2A7-M12	8,9	21,0	14,0	12,0	62,0	13,2	200/50									
50	10	2A10-M10	10,0	20,0	11,0	10,0	63,0	10,5	100/50	TN70SE	B15MD							
	12	2A10-M12	10,0	21,0	14,0	12,0	68,0	13,2	100/50									
	14	2A10-M14	10,0	25,0	16,0	14,0	72,0	15,0	150/50									
	16	2A10-M16	10,0	26,0	18,0	16,0	76,0	17,0	150/50									
63	10	2A14-M10	11,3	21,0	11,0	10,0	70,0	10,5	100/50	TN70SE	B15MD							
	12	2A14-M12	11,3	22,0	14,0	12,0	75,0	13,2	100/50									
70	14	2A14-M14	11,3	25,0	16,0	14,0	79,0	15,0	100/50	TN70SE	B15MD							
	16	2A14-M16	11,3	26,0	18,0	16,0	83,0	17,0	100/50									
95	10	2A19-M10	13,5	25,0	11,0	10,0	76,5	10,5	50/25	TN120 SE*	B15MD							
	12	2A19-M12	13,5	25,0	14,0	12,0	81,5	13,2	50/25									
	14	2A19-M14	13,5	25,0	16,0	14,0	85,5	15,0	75/25									
	16	2A19-M16	13,5	27,0	18,0	16,0	90,5	17,0	50/25									
120	10	2A24-M10	15,2	28,5	11,0	10,0	82,0	10,5	30/15	TN120 SE*	B15MD							
	12	2A24-M12	15,2	28,5	14,0	12,0	87,0	13,2	30/15									
	14	2A24-M14	15,2	28,5	16,0	14,0	91,0	15,0	30/15									
	16	2A24-M16	15,2	28,5	18,0	16,0	95,0	17,0	30/15									
125	20	2A24-M20	15,2	30,0	22,0	20,0	103,0	21,0	50/25	TN120 SE*	B15MD							
	10	2A30-M10	16,7	31,5	13,0	11,0	92,0	10,5	30/15									
	12	2A30-M12	16,7	31,5	16,0	14,0	98,0	13,2	30/15									
	14	2A30-M14	16,7	31,5	18,0	16,0	102,0	15,0	30/15									
150	16	2A30-M16	16,7	31,5	19,0	17,0	104,0	17,0	30/15	TN120 SE*	B15MD							
	20	2A30-M20	16,7	31,5	22,0	20,0	110,0	21,0	30/15									
	12	2A37-M12	19,2	35,5	16,0	14,0	108,0	13,2	20/10									
	14	2A37-M14	19,2	35,5	18,0	16,0	112,0	15,0	30/15									
185	16	2A37-M16	19,2	35,5	19,0	17,0	114,0	17,0	30/15	TN120 SE*	B15MD							
	20	2A37-M20	19,2	35,5	22,0	20,0	120,0	21,0	30/15									
	12	2A48-M12	21,1	39,0	16,0	14,0	109,0	13,2	20/5									
	14	2A48-M14	21,1	39,0	18,0	16,0	113,0	15,0	20/5									
240	16	2A48-M16	21,1	39,0	19,0	17,0	115,0	17,0	20/5	TN120 SE*	B15MD							
	20	2A48-M20	21,1	39,0	22,0	20,0	121,0	21,0	25/5									
	12	2A60-M12	23,7	44,0	20,0	14,0	129,5	13,2	15/5									
	14	2A60-M14	23,7	44,0	22,0	16,0	133,5	15,0	15/5									
300	16	2A60-M16	23,7	44,0	22,0	19,0	136,5	17,0	15/5	TN120 SE*	B15MD							
	20	2A60-M20	23,7	44,0	24,0	23,0	142,5	21,0	15/5									
	12	2A80-M12	27,0	51,0	22,0	19,0	140,0	13,2	15/5									
	14	2A80-M14	27,0	51,0	22,0	19,0	140,0	15,0	10/5									
400	16	2A80-M16	27,0	51,0	22,0	19,0	140,0	17,0	10/5	TN120 SE*	B15MD							
	20	2A80-M20	27,0	51,0	24,0	23,0	146,0	21,0	15/5									
	16	2A100-M16	30,3	56,5	22,0	19,0	141,0	17,0	10/1									
	20	2A100-M20	30,3	56,5	24,0	23,0	147,0	21,0	10/1									
500	16	2A120-M16*	33,4	61,5	22,0	19,0	159,0	17,0	20/1	TN120 SE*	B15MD							
	20	2A120-M20*	33,4	61,5	24,0	23,0	165,0	21,0	20/1									
630	16	2A160-M16*	38,0	72,0	24,0	23,0	187,0	21,0	12/1	TN120 SE*	B15MD							
	20	2A160-M20*	38,0	72,0	24,0	23,0	187,0	21,0	12/1									
800	20	2A200-M20*	44,0	80,0	24,0	23,0	202,0	21,0	6/1	TN120 SE*	B15MD							

*See page 161

*Not UL approved

HEAVY DUTY COPPER TUBE TERMINALS

2A-2M

double hole fixing - for Copper conductors

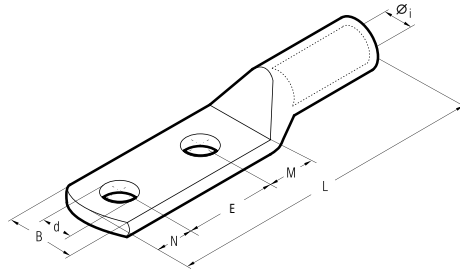

Conductor Size sqmm	Ø Stud mm	Type	Dimensions mm							Quantity Box/Bag	Mechanical Tools	Hydraulic Tools
			Øi	B	M	N	E	L	d			
50	12	2A10-2M12	10,0	21,0	14,0	12,0	44,5	112,5	13,2	75/25	TN70SE	B450ND-BV
70	12	2A14-2M12	11,3	22,0	16,0	14,0	44,5	123,5	13,2	50/25		
	14	2A14-2M14	11,3	25,0	18,0	16,0	44,5	127,5	15,0	75/25	TN120 SE*	B450ND-BV
95	12	2A19-2M12	13,5	25,0	16,0	14,0	44,5	128,0	13,2	50/25		
	14	2A19-2M14	13,5	25,0	18,0	16,0	44,5	132,0	15,0	50/25	HT45-E	HT51
120	12	2A24-2M12	15,2	28,5	16,0	14,0	44,5	135,5	13,2	50/25		
	14	2A24-2M14	15,2	28,5	18,0	16,0	44,5	139,5	15,0	50/25	RH50 B500	RH60C B600C
150	16	2A24-2M16	15,2	28,5	18,0	17,0	44,5	140,5	17,0	50/25		
	12	2A30-2M12	16,7	31,5	16,0	14,0	44,5	142,5	13,2	30/15	HT81-U	RHU81
	14	2A30-2M14	16,7	31,5	18,0	16,0	44,5	146,5	15,0	30/15		
185	12	2A37-2M12	19,2	35,5	16,0	14,0	44,5	152,5	13,2	30/15	RH50 B500	RH60C B600C
	14	2A37-2M14	19,2	35,5	18,0	16,0	44,5	156,5	15,0	30/15		
	16	2A37-2M16	19,2	35,5	19,0	17,0	44,5	158,5	17,0	30/15		
240	12	2A48-2M12	21,1	39,0	16,0	14,0	44,5	153,5	13,2	25/5	RH50 B500	RH60C B600C
	14	2A48-2M14	21,1	39,0	18,0	16,0	44,5	157,5	15,0	25/5		
	16	2A48-2M16	21,1	39,0	19,0	17,0	44,5	159,5	17,0	25/5		
	12	2A60-2M12	23,7	44,0	20,0	14,0	44,5	174,0	13,2	15/5	HT70 and tools and heads with 130 kN crimping force	ECW-H3D
300	14	2A60-2M14	23,7	44,0	22,0	16,0	44,5	178,0	15,0	20/5		
	16	2A60-2M16	23,7	44,0	19,0	17,0	44,5	176,0	17,0	20/5		
	12	2A80-2M12	27,0	51,0	20,0	14,0	44,5	177,5	13,2	15/5	RHU520	
400	14	2A80-2M14	27,0	51,0	22,0	16,0	44,5	181,5	15,0	10/5		
	16	2A80-2M16	27,0	51,0	22,0	19,0	44,5	184,5	17,0	15/5		
	12	2A100-2M12	30,3	56,5	20,0	14,0	44,5	178,5	13,2	10/5	RHU520	
500	14	2A100-2M14	30,3	56,5	22,0	16,0	44,5	182,5	15,0	10/1		
	16	2A100-2M16	30,3	56,5	22,0	19,0	44,5	185,5	17,0	8/1		
	12	2A120-2M12*	33,4	61,5	20,0	14,0	44,5	196,5	13,2	15/1	RHU520	
630	14	2A120-2M14*	33,4	61,5	22,0	19,0	44,5	200,5	15,0	15/1		
	16	2A120-2M16*	33,4	61,5	22,0	19,0	44,5	203,5	17,0	15/1		
	14	2A160-2M14*	38,0	72,0	22,0	19,0	44,5	225,5	15,0	10/1	RHU520	
800	16	2A160-2M16*	38,0	72,0	24,0	19,0	44,5	227,5	17,0	10/1		
	12	2A200-2M12*	44,0	80,0	20,0	14,0	44,5	233,5	13,2	6/2		
1000	16	2A200-2M16*	44,0	80,0	22,0	19,0	44,5	240,5	17,0	5/1	RHU520	
	20	2A200-2M20*	44,0	80,0	24,0	23,0	44,5	246,5	21,0	6/2		

*See page 161

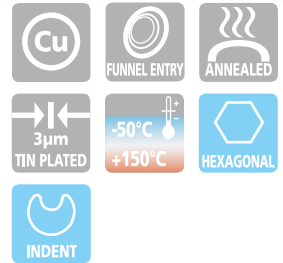

The 2A-2M series cable lugs are designed for heavy duty, for grounding structures and equipment both indoors and outdoors and for medium voltage applications up to 35 kV.

2A-2M series terminals are made from high purity Copper tube with a purity greater than 99.9%, and are annealed.

They feature a double length barrel for enhanced electrical and mechanical performance in heavy duty applications.

The double hole fixing ensures greater mechanical stability even in the presence of electrodynamic stresses.

The absence of an inspection hole prevents the entry of water or moisture into the crimped joint making these terminals suitable for outdoor applications.

The terminals are electrolytically Tin plated to prevent atmospheric corrosion.

Details of the appropriate crimping tools and dies are shown on pages 312 to 313.

*Not UL approved

L-M

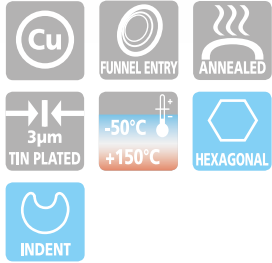

L-M range of connectors are designed for jointing low voltage conductors.

Made of electrolytic Copper tube with a purity greater than 99.9%, having the same dimension as A-M series lugs: L-M connectors are annealed and electrolytically Tin plated.

They feature an internal taper at both ends to ease the introduction of the conductor and a central stop to ensure correct positioning. Details of the appropriate crimping tools and dies are shown on pages 312 to 313.

THROUGH CONNECTORS

for Copper conductors

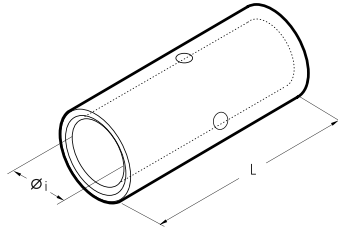

Conductor Size sqmm		Type	Dimensions mm		Quantity Box/Bag	Mechanical Tools	Hydraulic Tools
Low Stranded	Flexible		øi	L			
0,25÷1,5	0,25÷1,5	L03-M*	1,8	15	5.000/100	HN1	B15MD
1,5÷2,5	1,5÷2,5	L06-M*	2,4	15	4.000/100		
4÷6	4÷6	L1-M	3,6	22	2.000/100	HN5	B15MD
10	10	L2-M	4,6	25	1.000/100		
16	16	L3-M	5,8	27	500/100	HN-A25	B15MD
25	25	L5-M	7,0	29	500/100		
35	25÷35	L7-M	8,9	33	400/100	TN70SE	B15MD
50	35÷50	L10-M	10,0	37	200/50		
70	50÷70	L14-M	11,3	39	200/50	TN120 SE*	B15MD
95	70÷95	L19-M	13,5	43	100/25		
120	95÷120	L24-M	15,2	47	75/25	HT45-E B450ND-BV	HT51
150	120÷150	L30-M	16,7	58	50/25		
185	150÷185	L37-M	19,2	64	30/15	RH50 B500 B500ND	RH60C HT60C B600C B600CND
240	185÷240	L48-M	21,1	75	20/10		
300	240÷300	L60-M	23,7	90	20/10	RH60C HT60C B600C B600CND	RH50 B500 B500ND
400	300÷400	L80-M	27,0	94	15/5		
500	400÷500	L100-M	30,3	98	12/1	HT45-E B450ND-BV	HT51
630	500÷630	L120-M*	33,4	105	10/1		
800	600	L160-M*	38,0	112	6/1	RH50 B500 B500ND	RH60C HT60C B600C B600CND
1000	800	L200-M*	44,0	120	6/1		

*See page 161

L-P

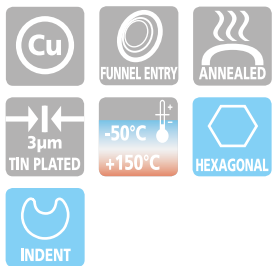

Made of electrolytic Copper tube with a purity greater than 99.9%, having the same dimensions as A-M series lugs, L-P connectors are annealed and electrolytically Tin plated.

They feature an internal taper to ease the introduction of the conductor.

Details of the appropriate crimping tools and dies are shown on pages 312 to 313.

PARALLEL CONNECTORS

for Copper conductors

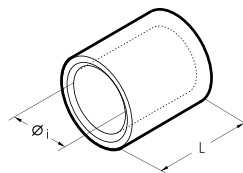

Total Conductor Size sqmm		Type	Dimensions mm		Quantity Box/Bag	Mechanical Tools	Hydraulic Tools
Low Stranded	Flexible		øi	L			
0,25÷1,5	0,25÷1,5	L03-P	1,8	6,0	8.000/100	HN1	B15MD
1,5÷2,5	1,5÷2,5	L06-P	2,4	6,0	5.000/100		
4÷6	4÷6	L1-P	3,6	9,0	3.000/100	HN5	B15MD
10	10	L2-P	4,6	10,5	2.000/100		
16	16	L3-P	5,8	11,5	1.500/100	HN-A25	B15MD
25	25	L5-P	7,0	13,0	1.000/100		
35	25÷35	L7-P	8,9	14,0	500/100	TN70SE	B15MD
50	35÷50	L10-P	10,0	16,0	500/100		
70	50÷70	L14-P	11,3	18,0	500/100	TN120 SE*	B15MD
95	70÷95	L19-P	13,5	19,0	200/50		
120	95÷120	L24-P	15,2	22,0	200/50	HT45-E B450ND-BV	HT51
150	120÷150	L30-P	16,7	26,5	100/50		
185	150÷185	L37-P	19,2	26,5	100/50	RH50 B500 B500ND	RH60C HT60C B600C B600CND
240	185÷240	L48-P	21,1	34,0	60/15		
300	240÷300	L60-P	23,7	43,0	50/25	RH60C HT60C B600C B600CND	RH50 B500 B500ND

*See page 161

*Not UL approved

COPPER TUBE LUGS 4-ESI FIXING

for Copper conductors

A-4ESI

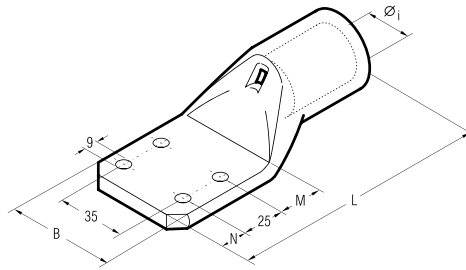

Conductor Size sqmm	Type	Dimensions mm					Quantity Box/Bag	Hydraulic Tools					
		Ø	B	M	N	L		HT51 B550	RH50 B500 B500ND	RH60C HT60C B600C B600CND	HT81-U RHU81	HT 120 and tools and heads with 130 kN crimping force	ECW-H3D
185	A 37-4ESI	19,2	61,0	20	15	124	20/10						
240	A 48-4ESI	21,1	61,0	20	15	128	20/10						
300	A 60-4ESI	23,7	61,0	20	15	133	15/5						
400	A 80-4ESI	27,0	61,0	20	15	134	15/5						
500	A 100-4ESI	30,3	61,0	20	15	139	10/5						
630	A 120-4ESI	33,4	61,6	20	15	144	10/5						
800	A 160-4ESI	38,0	61,0	20	15	158	8/1						



A-4ESI series lugs are made from electrolytic Copper tube with a purity greater than 99.9%, annealed and Tin plated.

The four hole stud fixing in accordance with E.A. specifications ensures compatibility with most transformer fixing arrangements.

Details of the appropriate crimping tools and dies are shown on pages 312 to 313.



A-P



Cu-ETP
Brazed
 SEAM
 ANNEALED
 3µm
 TIN PLATED
 -50°C
 +150°C
 INDENT
 HEXAGONAL

A-P series pin connectors are designed to terminate conductors into contact blocks. They are manufactured from Copper strip with a purity greater than 99.9%, rolled, brazed and Tin plated.

UNINSULATED PIN CONNECTORS

for Copper conductors

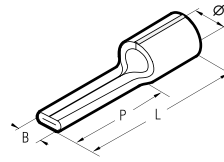

Conductor Size sqmm		Type	Dimensions mm				Quantity Box/Bag	Mechanical Tools				Hydraulic Tools												
Low Stranded	Flex		Øi	B	P	L		HN1	HN5	HN-A25	TN70SE	TN120SE	B15MD	HT45-E	B450ND-BV	HT51	RH50	B500	B500ND	RH60C	HT60C	B600C	B600CND	HT120 and tools and heads with 130 kN crimping force
10	10	A2-P12	4,8	4,3	14,5	23,5	1.500/100																	
16	16	A3-P14	5,9	5,5	18,0	28,0	1.000/100																	
25	25	A5-P16	7,0	7,0	20,3	32,0	500/100																	
35	25÷35	A7-P20	8,9	8,0	24,5	39,0	500/100																	
50	35÷50	A10-P25	10,0	9,5	26,0	45,0	250/50																	
70	50÷70	A14-P30	11,5	11,0	31,0	55,0	200/50																	

Details of the appropriate crimping tools and dies are shown on pages 312 to 313.

A-PR



Cu-ETP
Brazed
 SEAM
 ANNEALED
 3µm
 TIN PLATED
 -50°C
 +150°C
 INDENT
 HEXAGONAL

A-PR series pin connectors are designed to terminate conductors into contact blocks. They are manufactured from Copper strip with a purity greater than 99.9%, rolled, brazed and Tin plated.

UNINSULATED ROUND PIN CONNECTORS

for Copper conductors

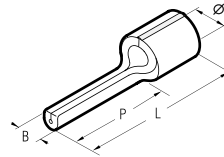

Conductor Size sqmm		Type	Dimensions mm				Quantity Box/Bag	Mechanical Tools				Hydraulic Tools												
Low Stranded	Flex		Øi	B	P	L		HN1	HN5	HN-A25	TN70SE	TN120SE	B15MD	HT45-E	B450ND-BV	HT51	RH50	B500	B500ND	RH60C	HT60C	B600C	B600CND	HT120 and tools and heads with 130 kN crimping force
16	16	A3-P22R	5,9	4,0	22,0	32,0	1.000/100																	
25	25	A5-P22R	7,0	4,0	22,0	33,7	500/100																	

Details of the appropriate crimping tools and dies are shown on pages 312 to 313.

UNINSULATED ROUND PIN CONNECTORS ANGLED 45°

for Copper conductors

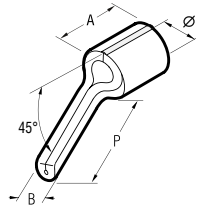

Conductor Size sqmm		Type	Dimensions mm				Quantity Box/Bag	Mechanical Tools				Hydraulic Tools										
Low Stranded	Flex		Øi	B	P	A		HNT	HNS	HN-A25	TN/0SE	TN120SE	BT15MD	HT45-E	B450ND-BV	HT51 RH50	B500 B500ND	RH60C	HT60C B600C	B600CND	HT120 and tools and heads with 130 kN crimping force	ECW-H3D
16	16	A3-P22R/45	5,9	4,0	22,0	10,0	1.000/100															
25	25	A5-P22R/45	7,0	4,0	22,0	11,7	500/100															

A-PR/45

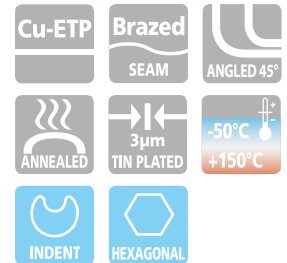

A-PR/45 series pin connectors are designed to terminate conductors into contact blocks.

They are manufactured from Copper strip with a purity greater than 99.9%, rolled, brazed and Tin plated.

Details of the appropriate crimping tools and dies are shown on pages 312 to 313.

UNINSULATED FORK TERMINALS

for Copper conductors

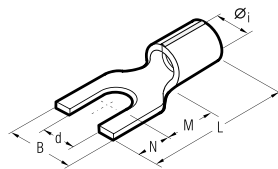

Conductor Size sqmm	Ø Stud mm	Type	Dimensions mm						Quantity Box/Bag	Mechanical Tools				Hydraulic Tools									
			Øi	B	M	N	L	d		HNT1	HNS	TN/0SE	TN120SE	BT15MD	HT45-E	B450ND-BV	HT51 RH50	B500 B500ND	RH60C	HT60C	B600CND	HT120 and tools and heads with 130 kN crimping force	ECW-H3D
10	4	A2-U4	4,8	9,8	7,5	7,0	23,5	4,3	1.500/100														
	5	A2-U5	4,8	11,5	7,5	7,0	23,5	5,3	1.500/100														
16	4	A3-U4	5,9	10,0	10,0	8,0	28,0	4,3	1.000/100														
	5	A3-U5	5,9	11,5	10,0	8,0	28,0	5,3	1.000/100														

A-U

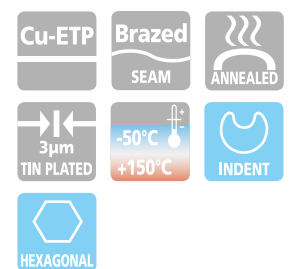

A-U series fork terminals are designed to terminate conductors into contact blocks.

Made from electrolytic Copper strip with a purity greater than 99.9%, rolled and Tin plated.

The seam is brazed to provide uniform mechanical strength.

The terminal barrel is rifled to enhance electrical contact and to improve mechanical strength. Recommended crimping tools are shown on pages 312 to 313.

for Copper conductors

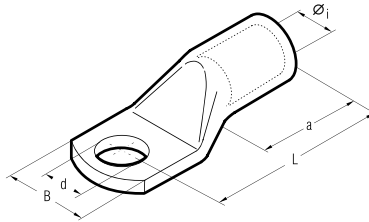

DR series lugs are manufactured from electrolytic Copper tube with a purity greater than 99.9%, and designed to obtain high electrical conductivity combined with the mechanical strength required to resist vibration and pull out.

CEMBRE lugs are annealed and Tin plated for improved surface protection.

The annealing process optimises the structural features of the material allowing easier crimping and greater resistance to mechanical stresses.

Dimensions are according to DIN 46235.

The barrel entrance of the lug is chamfered to allow easy conductor insertion, while its length facilitates precise positioning in the crimping die.

Each lug is marked with:

- CEMBRE logo and part code.
- conductor type and csa (mm²).
- stud Ø (mm).
- crimping die code

Details of the appropriate crimping tools and dies are shown on page 320.

Consult us for special requirements

Conductor Size sqmm	Ø Stud mm	Type	Code	Dimensions mm					Quantity Box/Bag	Mechanical Tools	Hydraulic Tools
				Øi	d	L	B	a			
6	5	DR6-5	5	3,8	5,3	25,0	8,5	10,0	800/100	HN-D25	B15MD
	6	DR6-6	5	3,8	6,4	25,0	8,5	10,0	800/100		
	8	DR6-8*	5	3,8	8,4	25,0	12,5	10,0	800/100		
10	5	DR10-5	6	4,5	5,3	28,0	9,0	13,0	800/100	TNE-D50	B15MD
	6	DR10-6	6	4,5	6,4	28,0	9,0	13,0	800/100		
	8	DR10-8*	6	4,5	8,4	28,0	13,0	13,0	800/100		
16	10	DR10-10*	6	4,5	10,5	28,0	17,0	13,0	800/100	TNE-D50	B15MD
	6	DR16-6	8	5,5	6,4	37,0	13,0	20,0	400/100		
	8	DR16-8	8	5,5	8,4	37,0	13,0	20,0	400/100		
25	10	DR16-10	8	5,5	10,5	37,0	17,0	20,0	400/100	TNE-D50	B15MD
	12	DR16-12*	8	5,5	13,0	39,0	19,0	20,0	400/100		
	6	DR25-6	10	7,0	6,4	39,0	14,0	20,0	400/100		
35	8	DR25-8	10	7,0	8,4	39,0	16,0	20,0	300/100	TNE-D20	B15MD
	10	DR25-10	10	7,0	10,5	39,0	17,0	20,0	200/100		
	12	DR25-12	10	7,0	13,0	40,0	19,0	20,0	200/100		
50	12	DR35-6*	12	8,2	6,4	41,0	17,0	20,0	200/100	TNE-D20	B15MD
	8	DR35-8	12	8,2	8,4	43,0	17,0	20,0	200/100		
	10	DR35-10	12	8,2	10,5	43,0	19,0	20,0	200/100		
70	12	DR35-12	12	8,2	13,0	43,0	21,0	20,0	200/100	TNE-D20	B15MD
	16	DR35-16*	12	8,2	17,0	47,0	26,0	20,0	200/100		
	6	DR50-6*	14	10,0	6,4	53,0	20,0	28,0	100/25		
95	8	DR50-8	14	10,0	8,4	53,0	20,0	28,0	100/25	TNE-D20	B15MD
	10	DR50-10	14	10,0	10,5	53,0	22,0	28,0	100/25		
	12	DR50-12	14	10,0	13,0	53,0	24,0	28,0	100/25		
120	16	DR50-16	14	10,0	17,0	53,0	28,0	28,0	100/25	TNE-D20	B15MD
	8	DR70-8	16	11,5	8,4	56,0	24,0	28,0	50/25		
	10	DR70-10	16	11,5	10,5	56,0	24,0	28,0	50/25		
150	12	DR70-12	16	11,5	13,0	56,0	24,0	28,0	50/25	TNE-D20	B15MD
	16	DR70-16	16	11,5	17,0	56,0	30,0	28,0	50/25		
	20	DR70-20*	16	11,5	21,0	64,0	30,0	28,0	50/25		
185	8	DR95-8*	18	13,5	8,4	66,0	28,0	35,0	50/25	TNE-D20	B15MD
	10	DR95-10	18	13,5	10,5	66,0	28,0	35,0	50/25		
	12	DR95-12	18	13,5	13,0	66,0	28,0	35,0	50/25		
240	16	DR95-16	18	13,5	17,0	66,0	32,0	35,0	50/25	TNE-D20	B15MD
	20	DR95-20*	18	13,5	21,0	74,0	32,0	35,0	50/25		
	8	DR120-8*	20	15,5	8,4	71,0	30,0	35,0	50/25		
320	10	DR120-10	20	15,5	10,5	71,0	32,0	35,0	30/15	TNE-D20	B15MD
	12	DR120-12	20	15,5	13,0	71,0	32,0	35,0	30/15		
	16	DR120-16	20	15,5	17,0	71,0	32,0	35,0	50/25		
400	20	DR120-20	20	15,5	21,0	70,5	38,0	35,0	50/25	TNE-D20	B15MD
	10	DR150-10	22	17,0	10,5	79,0	34,0	39,0	30/15		
	12	DR150-12	22	17,0	13,0	79,0	34,0	39,0	30/15		
500	16	DR150-16	22	17,0	17,0	79,0	34,0	39,0	40/20	TNE-D20	B15MD
	20	DR150-20	22	17,0	21,0	79,0	40,0	39,0	30/15		
	10	DR185-10	25	19,0	10,5	83,0	37,0	40,0	25/25		
630	12	DR185-12	25	19,0	13,0	83,0	37,0	40,0	25/25	TNE-D20	B15MD
	16	DR185-16	25	19,0	17,0	83,0	37,0	40,0	25/25		
	20	DR185-20	25	19,0	21,0	83,0	40,0	40,0	25/25		
800	10	DR240-10*	28	21,5	10,5	92,0	42,0	46,0	20/10	TNE-D20	B15MD
	12	DR240-12	28	21,5	13,0	92,0	42,0	46,0	20/10		
	16	DR240-16	28	21,5	17,0	93,0	42,0	46,0	20/10		
1000	20	DR240-20	28	21,5	21,0	93,0	45,0	46,0	20/10	TNE-D20	B15MD

* Dimensions of the tube according to DIN 46235; Stud hole not included within the standard.

COPPER TUBE CRIMPING LUGS ACCORDING TO DIN 46235

for Copper conductors

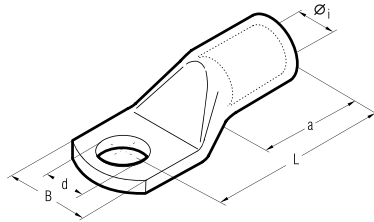

Conductor Size sqmm	Ø Stud mm	Type	Code	Dimensions mm					Quantity Box/Bag	Hydraulic Tools			
				Øi	d	L	B	a		RH50 B500 B500ND	RH60C HT60C B600C B600CND	HT120 and tools and heads with 130 kN crimping force	ECW-H3D RHU520
300	12	DR300-12*	32	24,5	13,0	101,0	48,0	51,0	10/5	ECW-H3D RHU520			
	16	DR300-16	32	24,5	17,0	101,0	48,0	51,0	10/5				
	20	DR300-20	32	24,5	21,0	101,0	48,0	51,0	10/5				
400	12	DR400-12**	38	27,5	13,0	116,0	55,0	70,0	5/5				
	16	DR400-16*	38	27,5	17,0	116,0	55,0	70,0	5/5				
	20	DR400-20*	38	27,5	21,0	116,0	55,0	70,0	5/5				
500	12	DR500-12**	42	31,0	13,0	125,0	60,0	70,0	5/5				
	16	DR500-16**	42	31,0	17,0	125,0	60,0	70,0	5/5				
	20	DR500-20*	42	31,0	21,0	125,0	60,0	70,0	5/5				
625	20	DR625-20*	44	34,5	21,0	136,0	60,0	80,0	5/5				
800	20	DR800-20*	52	40,0	21,0	166,0	75,0	100,0	5/5				
1.000	20	DR1000-20*	58	44,0	21,0	166,0	85,0	100,0	5/5				

* Dimensions of the tube according to DIN 46235; Stud hole not included within the standard.

**Not UL approved

DR



Consult us for special requirements

CRIMPING THROUGH CONNECTORS ACCORDING TO DIN 46267 T.1

for Copper conductors

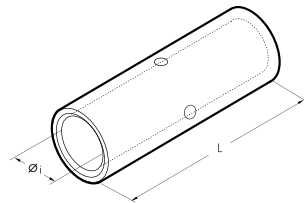

Conductor Size sqmm	Type	Code	Dimensions mm		Quantity Box/Bag	Mechanical Tools	Hydraulic Tools							
			Øi	L			B15MD	HT45-E B450ND-BV	HT51	RH50 B500 B500ND	RH60C HT60C B600C B600CND	HT81-U RHU81	HT120 and tools and heads with 130 kN crimping force	
6	DSV6	5	3,7	30	1.200/100	HIN-D25 TNE-D50 TNE-D120	B15MD	HT45-E B450ND-BV	HT51	RH50 B500 B500ND	RH60C HT60C B600C B600CND	HT81-U RHU81	HT120 and tools and heads with 130 kN crimping force	ECW-H3D RHU520
10	DSV10	6	4,4	30	1.200/100									
16	DSV16	8	5,5	50	400/100									
25	DSV25	10	7,0	50	200/100									
35	DSV35	12	8,2	50	200/100									
50	DSV50	14	10,0	56	200/50									
70	DSV70	16	11,5	56	100/50									
95	DSV95	18	13,5	70	100/50									
120	DSV120	20	15,5	70	50/25									
150	DSV150	22	17,0	80	50/25									
185	DSV185	25	19,0	85	25/25									
240	DSV240	28	21,5	90	15/15									
300	DSV300	32	24,5	100	10/5									
400	DSV400	38	27,5	150	10/5									
500	DSV500	42	31,0	160	5/5									
625	DSV625	44	34,5	160	5/5									
800	DSV800	52	40,0	200	5/5									
1.000	DSV1000	58	44,0	200	5/5									



DSV

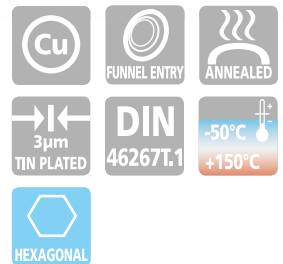

DSV series through connectors are manufactured from electrolytic Copper tube with a purity greater than 99.9%, annealed and surface protected by tin plating. Internal and external dimensions match those of DR series lugs. Chamfered ends and a central stop provide easy and correct insertion of the conductor. Details of the appropriate crimping tools and dies are shown on page 320.

Consult us for special requirements

HR

COPPER TUBE CRIMPING LUGS

for Copper conductors

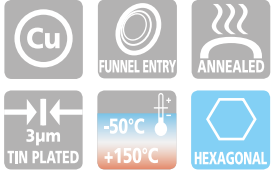
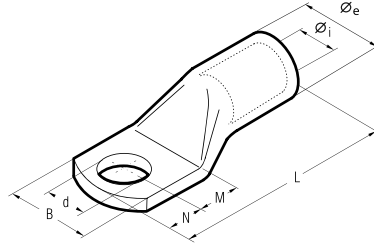

HR series lugs are manufactured from electrolytic Copper tube with a purity greater than 99.9%, and designed to obtain high electrical conductivity combined with the mechanical strength required to resist vibration and pull out.

CEMBRE lugs are annealed and Tin plated for improved surface protection.

The annealing process optimises the structural features of the material allowing easier crimping and greater resistance to mechanical stresses.

The barrel entrance of the lug is chamfered to allow easy conductor insertion, while its length facilitates precise positioning in the crimping die.

Each lug is marked with:

- CEMBRE logo and part code.
- conductor type and csa (mm²).
- stud Ø (mm).
- crimping die code

Details of the appropriate crimping tools and dies are shown on page 320.

Consult us for special requirements

Conductor Size sqmm	Ø Stud mm	Type	Dimensions mm							Quantity Box/Bag	Mechanical Tools		Hydraulic Tools		
			Øi	Øe	B	M	N	L	d						
6	4	HR6-4	3,5	6,5	10,0	7,5	6,5	27,5	4,3	800/100	HN1	HN5	HN-H25	B15MD	
	5	HR6-5	3,5	6,5	10,0	7,5	6,5	27,5	5,3	800/100					
	6	HR6-6	3,5	6,5	11,5	7,5	6,5	27,5	6,4	800/100					
	8	HR6-8	3,5	6,5	15,0	10,0	10,0	33,5	8,4	800/100					
	10	HR6-10	3,5	6,5	17,0	12,0	12,0	37,5	10,5	800/100					
	12	HR6-12	3,5	6,5	19,0	15,0	13,5	42,0	13,2	800/100					
10	4	HR10-4	4,5	7,0	12,0	7,5	6,5	28,5	4,3	800/100	HN1	HN5	HN-H25	B15MD	
	5	HR10-5	4,5	7,0	12,0	7,5	6,5	28,5	5,3	800/100					
	6	HR10-6	4,5	7,0	12,0	7,5	6,5	28,5	6,4	800/100					
	8	HR10-8	4,5	7,0	15,0	10,0	10,0	34,5	8,4	800/100					
	10	HR10-10	4,5	7,0	17,0	12,0	12,0	38,5	10,5	800/100					
	12	HR10-12	4,5	7,0	19,0	13,0	13,0	40,5	13,2	800/100					
16	5	HR16-5	5,5	8,5	12,0	7,0	6,0	31,5	5,3	400/100	HN1	HN5	HN-H25	B15MD	
	6	HR16-6	5,5	8,5	12,0	7,5	6,5	32,5	6,4	400/100					
	8	HR16-8	5,5	8,5	15,0	9,5	8,5	36,5	8,4	400/100					
	10	HR16-10	5,5	8,5	17,0	11,5	10,5	40,5	10,5	400/100					
	12	HR16-12	5,5	8,5	19,0	13,0	12,0	43,5	13,2	400/100					
	14	HR16-14	5,5	8,5	21,0	14,5	13,5	46,5	15,0	400/100					
25	5	HR25-5	7,0	10,0	14,0	7,5	7,5	37,0	5,3	400/100	HN1	HN5	HN-H25	B15MD	
	6	HR25-6	7,0	10,0	14,0	7,5	7,5	37,0	6,4	400/100					
	8	HR25-8	7,0	10,0	16,0	10,0	10,0	42,0	8,4	400/100					
	10	HR25-10	7,0	10,0	18,0	12,0	12,0	46,0	10,5	400/100					
	12	HR25-12	7,0	10,0	19,0	13,0	13,0	48,0	13,2	400/100					
	14	HR25-14	7,0	10,0	21,0	14,0	14,5	50,5	15,0	400/100					
35	6	HR35-6	8,5	12,0	17,0	7,5	7,5	39	6,4	200/50	HN1	HN5	HN-H25	B15MD	
	8	HR35-8	8,5	12,0	17,0	10,0	10,0	44	8,4	200/50					
	10	HR35-10	8,5	12,0	19,0	12,0	12,0	48	10,5	200/50					
	12	HR35-12	8,5	12,0	21,0	13,0	13,0	50	13,2	200/50					
	14	HR35-14	8,5	12,0	21,0	14,5	14,5	53	15,0	200/50					
	16	HR35-16	8,5	12,0	26,0	18,0	18,0	58	17,0	200/50					
50	6	HR50-6	10,0	14,0	20,0	10,0	10,0	47,0	6,4	200/50	HN1	HN5	HN-H25	B15MD	
	8	HR50-8	10,0	14,0	20,0	10,0	10,0	47,0	8,4	200/50					
	10	HR50-10	10,0	14,0	20,0	12,0	12,0	51,0	10,5	200/50					
	12	HR50-12	10,0	14,0	23,0	13,0	13,0	53,0	13,2	200/50					
	14	HR50-14	10,0	14,0	23,0	14,5	14,5	56,0	15,0	200/50					
	16	HR50-16	10,0	14,0	28,0	16,0	16,0	59,0	17,0	100/50					
70	20	HR50-20	10,0	14,0	30,0	19,0	19,0	65,0	21,0	100/50	HN1	HN5	HN-H25	B15MD	
	6	HR70-6	12,0	16,5	23,5	10,0	10,0	52,0	6,4	100/25					
	8	HR70-8	12,0	16,5	23,5	10,0	10,0	52,0	8,4	100/25					
	10	HR70-10	12,0	16,5	23,5	12,0	12,0	56,0	10,5	80/20					
	12	HR70-12	12,0	16,5	23,5	13,0	13,0	58,0	13,2	80/20					
	14	HR70-14	12,0	16,5	23,5	14,5	14,5	61,0	15,0	80/20					
95	16	HR70-16	12,0	16,5	28,0	16,0	16,0	64,0	17,0	60/15	HN1	HN5	HN-H25	B15MD	
	20	HR70-20	12,0	16,5	30,5	19,0	19,0	70,0	21,0	60/15					
	8	HR95-8	13,5	18,0	26,0	12,0	12,0	60,0	8,4	100/25					
	10	HR95-10	13,5	18,0	26,0	12,0	12,0	60,0	10,5	100/25					
	12	HR95-12	13,5	18,0	26,0	13,0	13,0	62,0	13,2	100/25					
	14	HR95-14	13,5	18,0	26,0	14,5	14,5	65,0	15,0	100/25					
120	16	HR95-16	13,5	18,0	28,0	16,0	16,0	68,0	17,0	100/25	HN1	HN5	HN-H25	B15MD	
	20	HR95-20	13,5	18,0	36,0	22,0	22,0	80,0	21,0	100/25					
	8	HR120-8	15,0	19,5	28,0	14,0	14,0	65,0	8,4	100/25					
	10	HR120-10	15,0	19,5	28,0	14,0	14,0	65,0	10,5	100/25					
	12	HR120-12	15,0	19,5	28,0	14,0	14,0	65,0	13,2	100/25					
	14	HR120-14	15,0	19,5	28,0	15,0	15,0	67,0	15,0	100/25					
150	16	HR120-16	15,0	19,5	30,0	16,0	16,0	69,0	17,0	100/25	HN1	HN5	HN-H25	B15MD	
	20	HR120-20	15,0	19,5	36,0	22,0	22,0	81,0	21,0	50/25					
	8	HR150-8	16,5	21,0	31,0	14,0	14,0	70,0	8,4	40/10					
	10	HR150-10	16,5	21,0	31,0	14,0	14,0	70,0	10,5	40/10					
	12	HR150-12	16,5	21,0	31,0	15,0	15,0	72,0	13,2	40/10					
	14	HR150-14	16,5	21,0	31,0	15,0	15,0	72,0	15,0	40/10					
150	16	HR150-16	16,5	21,0	31,0	16,0	16,0	74,0	17,0	40/10	HN1	HN5	HN-H25	B15MD	
	20	HR150-20	16,5	21,0	36,0	22,0	22,0	86,0	21,0	60/15					

HT45-E B450ND-BV
HT51 RH50 B500ND RH60C HT60C B600C B600CND HT81-U RHU81
HT120 and tools and heads with 130 kN crimping force
ECW-H3D

COPPER TUBE CRIMPING LUGS

for Copper conductors

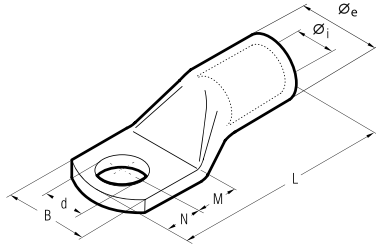

Conductor Size sqmm	Ø Stud mm	Type	Dimensions mm							Quantity Box/Bag	Hydraulic Tools					
			Øi	Øe	B	M	N	L	d		HT51	RH50 B500 B500ND	RH60C B600C B600CND	HT81-U RHU81	HT120 and tools and heads with 130 kN crimping force	ECW-H3D
185	10	HR185-10	19,0	24,0	35,0	18,0	18,0	83,0	10,5	40/10	HT51	RH50 B500 B500ND	RH60C B600C B600CND	HT81-U RHU81	HT120 and tools and heads with 130 kN crimping force	ECW-H3D
	12	HR185-12	19,0	24,0	35,0	18,0	18,0	83,0	13,2	40/10						
	14	HR185-14	19,0	24,0	35,0	18,0	18,0	83,0	15,0	40/10						
	16	HR185-16	19,0	24,0	35,0	18,0	18,0	83,0	17,0	40/10						
	20	HR185-20	19,0	24,0	35,0	22,0	22,0	91,0	21,0	40/10						
240	10	HR240-10	21,0	26,0	39,0	19,0	21,5	93,5	10,5	40/10						
	12	HR240-12	21,0	26,0	39,0	19,0	21,5	93,5	13,2	40/10						
	14	HR240-14	21,0	26,0	39,0	19,0	21,5	93,5	15,0	40/10						
	16	HR240-16	21,0	26,0	39,0	19,0	21,5	93,5	17,0	40/10						
	20	HR240-20	21,0	26,0	39,0	19,0	21,5	93,5	21,0	40/10						
300	12	HR300-12	23,5	29,5	43,0	24,0	24,0	111,0	13,2	10/5						
	14	HR300-14	23,5	29,5	43,0	24,0	24,0	111,0	15,0	10/5						
	16	HR300-16	23,5	29,5	43,0	24,0	24,0	111,0	17,0	10/5						
	20	HR300-20	23,5	29,5	43,0	24,0	24,0	111,0	21,0	10/5						

HR

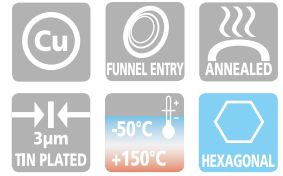

CRIMPING THROUGH CONNECTORS

for Copper conductors

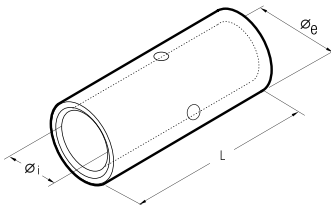

Conductor Size sqmm	Type	Dimensions mm			Quantity Box/Bag	Mechanical Tools				Hydraulic Tools							
		Øi	Øe	L		HN1	HN-5	HN-H25	TNE-H50	B15MD	HT45-E B450ND-BV	HT51	RH50 B500 B500ND	RH60C B600C B600CND	HT81-U RHU81	HT120 and tools and heads with 130 kN crimping force	ECW-H3D
10	HSV10	4,5	7,0	30	1200/100												
16	HSV16	5,5	8,5	35	800/100												
25	HSV25	7,0	10,0	40	400/100												
35	HSV35	8,5	12,0	45	200/50												
50	HSV50	10,0	14,0	50	200/50												
70	HSV70	12,0	16,5	55	160/40												
95	HSV95	13,5	18,0	60	80/10												
120	HSV120	15,0	19,5	65	80/10												
150	HSV150	16,5	21,0	70	80/10												
185	HSV185	19,0	24,0	75	40/20												
240	HSV240	21,0	26,0	85	40/20												
300	HSV300	23,5	29,5	100	20/10												

HSV

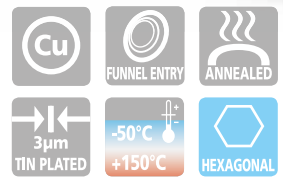

HSV series through connectors are manufactured from electrolytic Copper tube with a purity greater than 99.9%, annealed and surface protected by tin plating. Internal and external dimensions match those of HR series lugs. Chamfered ends and a central stop provide easy and correct insertion of the conductor. Details of the appropriate crimping tools and dies are shown on page 320.

Consult us for special requirements

T-M

COPPER TUBE CRIMPING LUGS ACCORDING TO NF C 20-130

for Copper conductors

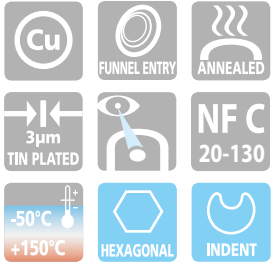
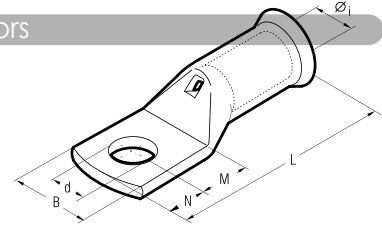

T-M series lugs are manufactured from electrolytic Copper tube with a purity greater than 99.9%.

The dimensions of the tube are designed to obtain the most efficient electrical conductivity and mechanical strength to resist vibration and pull out.

CEMBRE lugs are annealed to guarantee optimum ductility which is an absolute necessity for connectors which will have to withstand the severe deformation arising when compressed and any bending of the palm during installation. In applications subject to vibration, lugs still have to provide a reliable connection and annealing plays a vital role in avoiding cracking or breaks between the barrel and palm.

The insertion of the cable is facilitated by a tulip out.

The presence of an inspection hole facilitates full insertion of the conductor, whilst the barrel length has been designed to allow easy and accurate positioning of the dies during the crimping operation.

Lugs are electrolytically Tin plated to avoid oxidation.

Our technicians are always available to provide any technical advice which may be required.

The enclosed table is only indicative of the range and many variations in stud fixing and palm lengths are also available.

Details of the appropriate crimping tools and dies are shown on page 322.

Conductor Size sqmm	Low Str.	Flex	Ø Stud mm	Type	Dimensions mm						Quantity Box/Bag	Mechanical Tools	Hydraulic Tools
					Øi	B	M	N	L	d			
4			4	T4-M4	2,7	9,0	7,0	6,0	27,5	4,2	1.200/100	HN1	B15MD
			5	T4-M5	2,7	9,0	7,0	6,0	27,5	5,2	2.000/100		
			6	T4-M6	2,7	12,0	9,0	8,0	32,0	6,4	1.200/100		
4÷6			4	T6-M4	3,3	10,0	6,5	6,0	30,0	4,2	1.200/100	HN1	B15MD
			5	T6-M5	3,3	13,0	6,5	6,0	30,0	5,2	1.200/100		
			6	T6-M6	3,3	13,0	9,0	8,0	34,5	6,4	800/100		
10			8	T6-M8	3,3	13,0	11,0	10,0	38,5	8,3	800/100	HN5	B15MD
			5	T10-M5	4,2	11,0	6,5	6,0	30,0	5,2	800/100		
			6	T10-M6	4,2	11,0	9,0	8,0	34,5	6,4	800/100		
16			8	T10-M8	4,2	14,0	11,0	10,0	38,5	8,3	800/100	HN-T25	B15MD
			5	T16-M5	5,3	12,0	6,5	6,0	34,0	5,2	800/100		
			6	T16-M6	5,3	12,0	9,0	8,0	38,5	6,4	400/100		
25			8	T16-M8	5,3	16,0	11,0	10,0	42,5	8,3	400/100	HN-T50	B15MD
			10	T16-M10	5,3	16,0	14,0	12,0	47,5	10,3	400/100		
			5	T25-M5	6,6	13,0	6,5	6,0	35,5	5,2	400/100		
35			6	T25-M6	6,6	13,0	9,0	8,0	40,0	6,4	400/100	HN-T50	B15MD
			8	T25-M8	6,6	16,0	11,0	10,0	44,0	8,3	400/100		
			10	T25-M10	6,6	16,0	14,0	12,0	49,0	10,3	400/100		
50			12	T25-M12	6,6	19,0	18,0	16,0	57,0	12,8	200/50	HN-T120	B450ND-BV
			6	T35-M6	7,9	15,0	9,0	8,0	41,0	6,4	200/50		
			8	T35-M8	7,9	17,0	11,0	10,0	45,0	8,3	200/50		
70			10	T35-M10	7,9	17,0	14,0	12,0	50,0	10,3	200/50	HN-T120	HT45-E
			12	T35-M12	7,9	17,0	18,0	16,0	58,0	12,8	200/50		
			6	T50-M6	9,2	18,0	9,0	8,0	46,5	6,4	200/25		
95			8	T50-M8	9,2	18,0	11,0	10,0	50,5	8,3	200/25	HN-T120	HT45-E
			10	T50-M10	9,2	18,0	14,0	12,0	55,5	10,3	200/25		
			12	T50-M12	9,2	19,0	18,0	16,0	63,5	12,8	100/25		
120			8	T70-M8	11,0	21,0	11,0	10,0	54,0	8,3	100/25	HN-T120	HT45-E
			10	T70-M10	11,0	21,0	14,0	12,0	59,0	10,3	100/25		
			12	T70-M12	11,0	21,0	18,0	16,0	67,0	12,8	100/25		
150			14	T95-M14	13,1	23,0	18,0	16,0	73,0	12,8	80/20	HN-T120	HT45-E
			16	T95-M16	13,1	23,0	19,0	17,0	75,0	16,5	80/20		
			8	T120-M8	14,5	28,0	11,0	10,0	63,0	8,3	100/25		
185			10	T120-M10	14,5	28,0	14,0	12,0	68,0	10,3	50/25	HN-T120	HT45-E
			12	T120-M12	14,5	28,0	18,0	16,0	76,0	12,8	50/25		
			14	T120-M14	14,5	28,0	18,0	16,0	76,0	14,5	50/25		
240			16	T120-M16	14,5	28,0	19,0	17,0	78,0	16,5	50/25	HN-T120	HT45-E
			8	T150-M8	16,2	30,0	11,0	10,0	72,5	8,3	40/10		
			10	T150-M10	16,2	30,0	14,0	12,0	77,5	10,3	40/10		
300			12	T150-M12	16,2	30,0	18,0	16,0	85,5	12,8	40/10	HN-T120	HT45-E
			14	T150-M14	16,2	30,0	18,0	16,0	85,5	14,5	40/10		
			16	T150-M16	16,2	30,0	19,0	17,0	87,5	16,5	40/10		
400			10	T185-M10	18,0	33,0	14,0	12,0	83,5	10,3	40/10	HN-T120	HT45-E
			12	T185-M12	18,0	33,0	18,0	16,0	91,5	12,8	40/10		
			14	T185-M14	18,0	33,0	18,0	16,0	91,5	14,5	40/10		
400			16	T185-M16	18,0	33,0	19,0	17,0	93,5	16,5	40/10	HN-T120	HT45-E
			10	T240-M10	20,6	37,0	13,0	11,0	87,5	10,3	20/10		
			12	T240-M12	20,6	37,0	16,0	14,0	93,5	12,8	20/10		
400			14	T240-M14	20,6	37,0	18,0	16,0	97,5	14,5	20/10	HN-T120	HT45-E
			16	T240-M16	20,6	37,0	19,0	17,0	99,5	16,5	20/10		
			20	T240-M20	20,6	37,0	22,0	20,0	105,5	21,0	20/10		
400			10	T300-M10	23,1	41,0	14,0	11,0	95,0	10,3	20/5	HN-T120	HT45-E
			12	T300-M12	23,1	41,0	20,0	14,0	104,0	12,8	20/5		
			14	T300-M14	23,1	41,0	22,0	16,0	108,0	14,5	20/5		
400			16	T300-M16	23,1	41,0	22,0	19,0	111,0	16,5	20/5	HN-T120	HT45-E
			20	T300-M20	23,1	41,0	24,0	23,0	117,0	21,0	10/5		
			14	T400-M14	26,1	47,0	22,0	19,0	119,0	14,5	10/5		
400			16	T400-M16	26,1	47,0	22,0	19,0	119,0	16,5	10/5	HN-T120	HT45-E
			20	T400-M20	26,1	47,0	24,0	23,0	125,0	21,0	10/5		

HT45-E B450ND-BV
HT51
RH50 B500
RH50 B500ND
HT81-U RHU81
HT120 and tools and heads with 130 kN crimping force
ECW-H3D
RHU520

COPPER TUBE CRIMPING LUGS ANGLED 90°

for Copper conductors

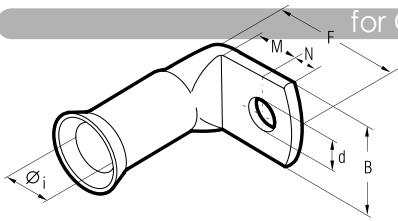

Conductor Size sqmm		Type	Dimensions mm						Quantity Box/Bag	Mechanical Tools	Hydraulic Tools							
Low Str.	Flex		Øi	B	M	N	F*	d										
4÷6	6	T6-L6	3,3	13,0	9,0	8,0	23,6	6,4	800/100	HNT	B15MD	HT45-E B450ND-BV	RH50 B500 B500ND	HT81-U RHU81	HT120 and tools and heads with 130 kN crimping force	ECW-H3D	RHU520	
		5	T10-L5	4,2	11,0	6,0	6,0	20,3										5,2
10	6	T10-L6	4,2	11,0	8,0	8,0	24,8	6,4	800/100	HN1	B15MD	HT45-E B450ND-BV	RH50 B500 B500ND	HT81-U RHU81	HT120 and tools and heads with 130 kN crimping force	ECW-H3D	RHU520	
		8	T10-L8	4,2	14,0	11,0	10,0	28,8										8,3
16	6	T16-L6	5,3	12,0	9,0	8,0	26,5	6,4	400/100	HN5	B15MD	HT45-E B450ND-BV	RH50 B500 B500ND	HT81-U RHU81	HT120 and tools and heads with 130 kN crimping force	ECW-H3D	RHU520	
		8	T16-L8	5,3	16,0	11,0	10,0	30,5										8,3
25	6	T25-L6	6,6	13,0	9,0	8,0	28,0	6,4	400/100	HN-T25	B15MD	HT45-E B450ND-BV	RH50 B500 B500ND	HT81-U RHU81	HT120 and tools and heads with 130 kN crimping force	ECW-H3D	RHU520	
		8	T25-L8	6,6	16,0	11,0	10,0	32,0										8,3
35	6	T35-L6	7,9	15,0	9,0	8,0	29,5	6,4	400/50	HN-T50	B15MD	HT45-E B450ND-BV	RH50 B500 B500ND	HT81-U RHU81	HT120 and tools and heads with 130 kN crimping force	ECW-H3D	RHU520	
		8	T35-L8	7,9	17,0	11,0	10,0	33,5										8,3
50	6	T50-L6	9,2	18,0	9,0	8,0	31,5	6,4	100/25	TNE-T50	B15MD	HT45-E B450ND-BV	RH50 B500 B500ND	HT81-U RHU81	HT120 and tools and heads with 130 kN crimping force	ECW-H3D	RHU520	
		8	T50-L8	9,2	18,0	10,0	10,0	35,5										8,3
70	6	T70-L6	11,0	21,0	9,0	8,0	38,5	6,4	100/25	TNE-T120	B15MD	HT45-E B450ND-BV	RH50 B500 B500ND	HT81-U RHU81	HT120 and tools and heads with 130 kN crimping force	ECW-H3D	RHU520	
		8	T70-L8	11,0	21,0	11,0	10,0	38,5										8,3
95	6	T95-L6	13,1	23,0	9,0	8,0	41,0	6,4	100/25	TNE-T120	B15MD	HT45-E B450ND-BV	RH50 B500 B500ND	HT81-U RHU81	HT120 and tools and heads with 130 kN crimping force	ECW-H3D	RHU520	
		8	T95-L8	13,1	23,0	11,0	10,0	41,0										8,3
120	6	T120-L6	14,5	28,0	9,0	8,0	48,0	6,4	50/25	TNE-T120	B15MD	HT45-E B450ND-BV	RH50 B500 B500ND	HT81-U RHU81	HT120 and tools and heads with 130 kN crimping force	ECW-H3D	RHU520	
		8	T120-L8	14,5	28,0	11,0	10,0	48,0										8,3
150	6	T150-L6	16,2	30,0	9,0	8,0	50,0	6,4	40/10	TNE-T120	B15MD	HT45-E B450ND-BV	RH50 B500 B500ND	HT81-U RHU81	HT120 and tools and heads with 130 kN crimping force	ECW-H3D	RHU520	
		8	T150-L8	16,2	30,0	11,0	10,0	50,0										8,3
185	10	T185-L10	18,0	33,0	14,0	12,0	52,0	10,3	40/10									

T-L

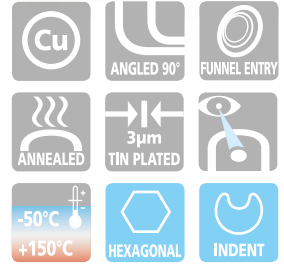

T-L series lugs angled 90° are manufactured from electrolytic Copper tube with a purity greater than 99.9%.

T-L series lugs having the same dimensions and characteristics as T-M series lugs.

F* = indicative dimension

Details of the appropriate crimping tools and dies are shown on page 322.

CRIMPING THROUGH CONNECTORS

for Copper conductors

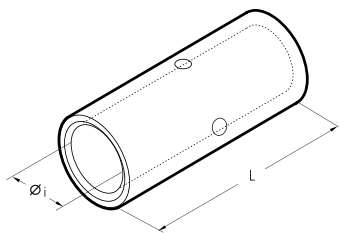

Total Conductor Size sqmm		Type	Dimensions mm		Quantity Box/Bag	Mechanical Tools	Hydraulic Tools
Low Stranded	Flexible		Øi	L			
4	4	L4-T	2,7	22	2.000/100	HN1	B15MD
4÷6	4÷6	L6-T	3,3	25	1.500/100		
10	10	L10-T	4,2	27	1.000/100	HN5	B15MD
16	16	L16-T	5,3	31	500/100		
25	25	L25-T	6,6	35	500/100	HN-A25	B15MD
35	25	L35-T	7,9	37	250/50		
50	35	L50-T	9,2	45	250/50	TNE-T50	B15MD
70	50	L70-T	11,0	50	200/50		
95	70	L95-T	13,1	56	100/25	TNE-T120	B15MD
120	95	L120-T	14,5	60	100/25		
150	120	L150-T	16,2	66	50/25	TNE-T120	B15MD
185	150	L185-T	18,0	75	50/25		
240	185	L240-T	20,6	80	30/15	TNE-T120	B15MD
300	240	L300-T	23,1	90	20/10		
400	300	L400-T	26,1	100	20/5		

L-T



Made of electrolytic Copper tube with a purity greater than 99.9%, having the same dimensions as T-M series lugs, L-T connectors are annealed and electrolytically Tin plated. They feature an internal taper to ease the introduction of the conductor.

Details of the appropriate crimping tools and dies are shown on page 322.



COLOUR CODED COPPER CRIMPING LUGS

for Copper conductors

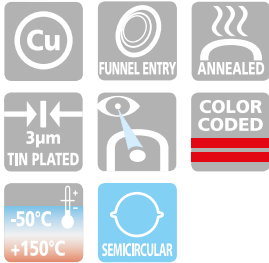
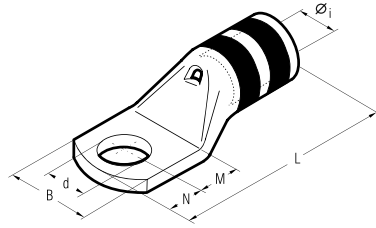

C series lugs are manufactured from electrolytic Copper tube with a purity greater than 99.9%.

The dimensions of the tube are designed to obtain the most efficient electrical conductivity and mechanical strength to resist vibration and pull out.

CEMBRE lugs are annealed to guarantee optimum ductility, an absolute necessity for connectors which will have to withstand the severe deformation arising when compressed and any bending of the palm during installation.

In applications subject to vibration, terminals have to perform a reliable connection, the annealing process plays a vital role in avoiding cracking or breaks between the barrel and palm.

The presence of an inspection hole facilitates full insertion of the conductor. The barrel length has been designed to allow easy and accurate positioning of the dies during the crimping operation.

Lugs are electrolytically Tin plated to avoid oxidation.

The tongue is clearly marked with wire size and die index for CEMBRE tools.

UL listed for US and Canada per UL486A up to 35 KV.

C series lugs are an important part of CEMBRE crimping systems for power carrying conductors.

Details of the appropriate crimping tools and dies are shown on page 321.

CEMBRE technicians are available to provide technical advice as required.

Please consult CEMBRE for products not listed.

Cond. Size sqmm	Conductor		Type	Dimensions mm						Colour Code	Quantity Box/Bag	Mechanical Tools	Hydraulic Tools
	AWG	Size		Ø Stud mm	Øi	B	M	N	L				
10	8	23	4 C8-8	4,6	10,0	5,0	4,0	22,5	4,3	RED	600/50	TN705E	B15MD
			5 C8-10	4,6	10,0	6,5	6,0	26,0	5,3		600/50		
			6 C8-14	4,6	11,0	7,0	6,0	26,5	6,4		600/50		
			8 C8-516	4,6	15,0	9,0	8,0	30,5	8,4		400/50		
			10 C8-38	4,6	18,0	11,0	10,0	34,5	10,5		600/50		
12 C8-12	4,6	19,0	14,0	12,0	39,5	13,2	600/50						
16	6	40	4 C6-8	5,8	11,5	5,0	4,0	25,5	4,3	BLUE	600/50		
			5 C6-10	5,8	11,5	6,5	6,0	29,0	5,3		600/50		
			6 C6-14	5,8	11,5	7,0	6,0	29,5	6,4		600/50		
			8 C6-516	5,8	15,0	9,0	8,0	33,5	8,4		600/50		
			10 C6-38	5,8	18,0	11,0	10,0	37,5	10,5		600/50		
12 C6-12	5,8	20,0	14,0	12,0	43,5	13,2	400/50						
25	4	40	4 C4-8	6,2	12,5	5,0	4,0	25,5	4,3	GREY	600/50		
			5 C4-10	6,2	12,5	6,5	6,0	29,0	5,3		600/50		
			6 C4-14	6,2	12,5	7,0	6,0	29,5	6,4		600/50		
			8 C4-516	6,2	15,0	9,0	8,0	33,5	8,4		600/50		
			10 C4-38	6,2	18,0	11,0	10,0	37,5	10,5		400/50		
12 C4-12	6,2	20,0	14,0	12,0	42,5	13,2	400/50						
	3	50	4 C3-8	7,0	14,0	5,0	4,0	28,0	4,3	WHITE	600/50		
			5 C3-10	7,0	14,0	6,5	6,0	31,5	5,3		600/50		
			6 C3-14	7,0	14,0	7,0	6,0	32,0	6,4		600/50		
			8 C3-516	7,0	15,0	9,0	8,0	36,0	8,4		600/50		
			10 C3-38	7,0	18,0	11,0	10,0	40,0	10,5		400/50		
12 C3-12	7,0	21,0	14,0	12,0	45,0	13,2	400/50						
35	2	60	5 C2-10	7,6	17,0	6,5	6,0	33,0	5,3	BROWN	400/50		
			6 C2-14	7,6	17,0	7,0	6,0	33,5	6,4		400/50		
			8 C2-516	7,6	17,0	9,0	8,0	37,5	8,4		400/50		
			10 C2-38	7,6	19,0	11,0	10,0	41,5	10,5		400/50		
			12 C2-12	7,6	21,0	14,0	12,0	46,5	13,2		200/50		
	1	75	6 C1-14	8,9	17,0	7,0	6,0	34,5	6,4	GREEN	400/50		
			8 C1-516	8,9	17,0	9,0	8,0	38,5	8,4		400/50		
			10 C1-38	8,9	19,0	11,0	10,0	42,5	10,5		200/50		
			12 C1-12	8,9	21,0	14,0	12,0	47,5	13,2		200/50		
			6 C1/0-14	10,0	19,0	8,0	7,0	40,5	6,4		200/25		
50	1/0	100	8 C1/0-516	10,0	19,0	9,0	8,0	42,5	8,4	PINK	200/25		
			10 C1/0-38	10,0	20,0	11,0	10,0	46,5	10,5		200/25		
			12 C1/0-12	10,0	21,0	14,0	12,0	51,5	13,2		200/25		
			14 C1/0-916	10,0	25,0	16,0	14,0	55,5	15,0		200/25		
			16 C1/0-58	10,0	26,0	18,0	16,0	59,5	17,0		200/25		
70	2/0	125	6 C2/0-14	11,3	21,0	8,0	7,0	44,0	6,4	BLACK	200/25		
			8 C2/0-516	11,3	21,0	9,0	8,0	46,0	8,4		200/25		
			10 C2/0-38	11,3	21,0	11,0	10,0	50,0	10,5		200/25		
			12 C2/0-12	11,3	22,0	14,0	12,0	55,0	13,2		200/25		
			14 C2/0-916	11,3	25,0	16,0	14,0	59,0	15,0		100/25		
			16 C2/0-58	11,3	26,0	18,0	16,0	63,0	17,0		100/25		
			20 C2/0-34	11,3	29,5	22,0	20,0	75,0	21,0		100/25		
95	3/0	150	6 C3/0-14	12,4	23,0	8,0	7,0	45,0	6,4	ORANGE	200/25		
			8 C3/0-516	12,4	23,0	9,0	8,0	47,0	8,4		100/25		
			10 C3/0-38	12,4	23,0	11,0	10,0	51,0	10,5		100/25		
			12 C3/0-12	12,4	24,0	14,0	12,0	56,0	13,2		100/25		
			14 C3/0-916	12,4	27,0	16,0	14,0	60,0	15,0		100/25		
			16 C3/0-58	12,4	28,0	18,0	16,0	64,0	17,0		100/25		
			20 C3/0-34	12,4	31,5	22,0	20,0	72,0	21,0		100/25		

COLOUR CODED COPPER CRIMPING LUGS

for Copper conductors

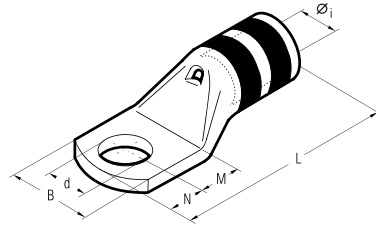

Cond. Size sqmm	Sez. Cond. AWG		Ø Stud mm	Type	Dimensions mm						Colour Code	Quantity Box/Bag	Mechanical Tools	Hydraulic Tools
	Size	Navy			Øi	B	M	N	L	d				
4/0	200	6	C4/0-14	13,5	25,0	8,0	7,0	50,5	6,4	PURPLE	100/25	TNI20SE	HT51 RH50 B500ND HT120 and tools and heads with 130 kN crimping force ECW-H3D RHU520	
		8	C4/0-516	13,5	25,0	9,0	8,0	52,5	8,4		100/25			
		10	C4/0-38	13,5	25,0	11,0	10,0	56,5	10,5		100/25			
		12	C4/0-12	13,5	25,0	14,0	12,0	61,5	13,2		100/25			
		14	C4/0-916	13,5	25,0	16,0	14,0	65,5	15,0		100/25			
		16	C4/0-58	13,5	27,0	18,0	16,0	69,5	17,0		50/25			
120	250 MCM	20	C4/0-34	13,5	29,5	22,0	20,0	77,5	21,0	50/25				
		6	C250-14	15,2	28,5	8,0	7,0	52,0	6,4	YELLOW	100/25			
		8	C250-516	15,2	28,5	9,0	8,0	54,0	8,4		100/25			
		10	C250-38	15,2	28,5	11,0	10,0	58,0	10,5		100/25			
		12	C250-12	15,2	28,5	14,0	12,0	63,0	13,2		50/25			
		14	C250-916	15,2	28,5	16,0	14,0	67,0	15,0		50/25			
16	C250-58	15,2	28,5	18,0	16,0	71,0	17,0	50/25						
150	300 MCM	20	C250-34	15,2	30,0	22,0	20,0	79,0	21,0	50/25				
		22	C250-78	15,2	32,0	24,0	23,0	84,0	23,0	50/25				
		8	C300-516	16,7	31,5	13,0	11,0	69,0	8,4	WHITE	40/10			
		10	C300-38	16,7	31,5	13,0	11,0	69,0	10,5		40/10			
		12	C300-12	16,7	31,5	16,0	14,0	75,0	13,2		40/10			
		14	C300-916	16,7	31,5	18,0	16,0	79,0	15,0		40/10			
16	C300-58	16,7	31,5	19,0	17,0	81,0	17,0	40/10						
20	C300-34	16,7	31,5	22,0	20,0	87,0	21,0	40/10						
185	350 MCM	22	C300-78	16,7	31,5	24,0	23,0	92,0	23,0	40/10				
		10	C350-38	17,6	33,0	13,0	11,0	70,5	10,5	RED	40/20			
		12	C350-12	17,6	33,0	16,0	14,0	76,5	13,2		40/20			
		14	C350-916	17,6	33,0	18,0	16,0	80,5	15,0		40/20			
		16	C350-58	17,6	33,0	19,0	17,0	82,5	17,0		40/20			
		20	C350-34	17,6	33,0	22,0	20,0	88,5	21,0		40/20			
22	C350-78	17,6	37,0	24,0	23,0	93,5	23,0	30/15						
400	400 MCM	10	C400-38	19,2	35,5	13,0	11,0	76,0	10,5	BLUE	40/20			
		12	C400-12	19,2	35,5	16,0	14,0	82,0	13,2		40/20			
		14	C400-916	19,2	35,5	18,0	16,0	86,0	15,0		40/20			
		16	C400-58	19,2	35,5	19,0	17,0	88,0	17,0		40/20			
		20	C400-34	19,2	35,5	22,0	20,0	94,0	21,0		40/20			
		22	C400-78	19,2	35,5	24,0	23,0	99,0	23,0		40/20			
240	500 MCM	10	C500-38	21,1	39,0	13,0	11,0	82,0	10,5	BROWN	30/15			
		12	C500-12	21,1	39,0	16,0	14,0	88,0	13,2		30/15			
		14	C500-916	21,1	39,0	18,0	16,0	92,0	15,0		30/15			
		16	C500-58	21,1	39,0	19,0	17,0	94,0	17,0		30/15			
		20	C500-34	21,1	39,0	22,0	20,0	100,0	21,0		20/10			
		22	C500-78	21,1	39,0	24,0	23,0	105,0	23,0		20/10			
300	600 MCM	12	C600-12	23,7	44,0	20,0	14,0	99,0	13,2	GREEN	20/10			
		14	C600-916	23,7	44,0	22,0	16,0	103,0	15,0		20/10			
		16	C600-58	23,7	44,0	22,0	19,0	106,0	17,0		20/10			
		20	C600-34	23,7	44,0	24,0	23,0	112	21,0		10/5			
750	MCM	22	C600-78	23,7	44,0	24,0	23,0	112,0	23,0	10/5				
		12	C750-12	26,0	48,0	22,0	19,0	113,0	13,2	BLACK	10/5			
		16	C750-58	26,0	48,0	22,0	19,0	113,0	17,0		10/5			
		20	C750-34	26,0	48,0	24,0	23,0	119,0	21,0		10/5			
22	C750-78	26,0	48,0	24,0	23,0	119,0	23,0	10/5						

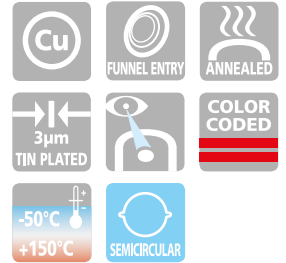

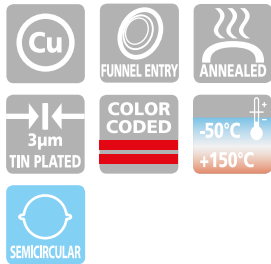
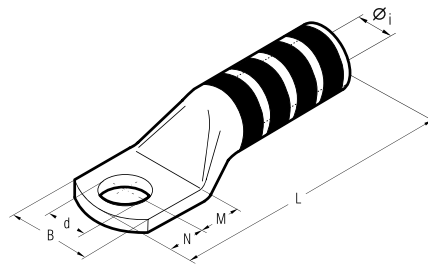

CL series lugs are manufactured from electrolytic Copper tube with a purity greater than 99.9%, for use in heavy duty applications.

The dimensions of the tube are designed to obtain the most efficient electrical conductivity and mechanical strength to resist vibration and pull out.

CEMBRE lugs are annealed to guarantee optimum ductility which is an absolute necessity for connectors which will have to withstand the severe deformation arising when compressed and any bending of the palm during installation. In applications subject to vibration, terminals have to perform a reliable connection, the annealing process plays a vital role in avoiding cracking or breaks between the barrel and palm.

The long barrel provides better mechanical pull-out strength. Lugs are electrolytically Tin plated to avoid oxidation.

The tongue is clearly marked with wire size and die index for CEMBRE tools.

UL listed for US and Canada per UL486A up to 35 KV.

CL series lugs are an important part of CEMBRE crimping systems for power carrying conductors.

Details of the appropriate crimping tools and dies are shown on page 321.

CEMBRE technicians are available to provide technical advice as required. Please consult CEMBRE for products not listed.

Cond. Size sqmm	Conductor AWG	Ø Stud mm	Type	Dimensions mm						Colour Code	Quantity Box/Bag	Mechanical Tools	Hydraulic Tools
				Øi	B	M	N	L	d				
10	8	23	5 CL8-10	4,6	10,0	6,5	6,0	37,5	5,3	RED	400/50	TN120SE	B15MD
			6 CL8-14	4,6	11,0	7,0	6,0	38,0	6,4		400/50		
			10 CL8-38	4,6	18,0	11,0	10,0	46,0	10,5		400/50		
16	6	60	5 CL6-10	5,8	11,5	6,5	6,0	40,0	5,3	BLUE	400/50		
			6 CL6-14	5,8	11,5	7,0	6,0	40,5	6,4		400/50		
			12 CL6-12	5,8	20,0	14,0	12,0	53,5	13,2		400/50		
25	4	40	5 CL4-10	6,2	12,5	6,5	6,0	47,0	5,3	GREY	400/50		
			6 CL4-14	6,2	12,5	7,0	6,0	47,5	6,4		400/50		
			10 CL4-38	6,2	18,0	11,0	10,0	55,5	10,5		400/50		
35	2	60	12 CL4-12	6,2	20,0	14,0	12,0	60,5	13,2	WHITE	400/50		
			6 CL3-14	7,0	14,0	7,0	6,0	47,5	6,4		200/100		
			8 CL3-516	7,0	15,0	9,0	8,0	51,5	8,4		200/100		
50	1/0	100	10 CL3-38	7,0	18,0	11,0	10,0	55,5	10,5	BROWN	200/50		
			12 CL3-12	7,0	21,0	14,0	12,0	60,5	13,2		200/100		
			5 CL2-10	7,6	17,0	6,5	6,0	46,0	5,3		200/50		
70	2/0	125	6 CL2-14	7,6	17,0	7,0	6,0	46,5	6,4	GREEN	200/50		
			8 CL2-516	7,6	17,0	9,0	8,0	50,5	8,4		200/50		
			12 CL2-12	7,6	21,0	14,0	12,0	59,5	13,2		200/50		
95	3/0	150	5 CL1-10	8,9	17,0	6,5	6,0	48,0	5,3	PINK	200/50		
			8 CL1-516	8,9	17,0	9,0	8,0	52,5	8,4		200/50		
			12 CL1-12	8,9	21,0	14,0	12,0	61,5	13,2		200/50		
120	250 MCM	250	10 CL1/0-10	10,0	19,0	8,0	7,0	53,5	5,3	BLACK	100/50		
			8 CL1/0-516	10,0	19,0	9,0	8,0	55,5	8,4		100/50		
			10 CL1/0-38	10,0	20,0	11,0	10,0	59,5	10,5		100/50		
150	300 MCM	300	12 CL1/0-12	10,0	21,0	14,0	12,0	64,5	13,2	ORANGE	100/50		
			10 CL2/0-38	11,3	21,0	11,0	10,0	67,5	10,5		100/50		
			12 CL2/0-12	11,3	22,0	14,0	12,0	72,5	13,2		100/50		
185	350 MCM	350	12 CL3/0-12	12,4	24,0	14,0	12,0	71,5	13,2	PURPLE	60/30		
			10 CL4/0-38	13,5	25,0	11,0	10,0	73,5	10,5		60/30		
			12 CL4/0-12	13,5	25,0	14,0	12,0	78,5	13,2		60/30		
240	500 MCM	500	12 CL250-12	15,2	28,5	14,0	12,0	84,0	13,2	YELLOW	50/25		
			12 CL300-12	16,7	31,5	16,0	14,0	98,0	13,2		30/15		
			12 CL350-12	17,6	33,0	16,0	14,0	98,0	13,2		30/15		
300	600 MCM	600	12 CL400-12	19,2	35,5	16,0	14,0	107,0	13,2	BLUE	20/10		
			16 CL400-58	19,2	35,5	19,0	17,0	113,0	17,0		20/10		
			12 CL500-12	21,1	39,0	16,0	14,0	108,0	13,2		20/10		
300	750 MCM	750	16 CL500-58	21,1	39,0	19,0	17,0	114,0	17,0	BROWN	20/10		
			12 CL600-12	23,7	44,0	20,0	14,0	128,5	13,2		10/5		
			16 CL600-58	23,7	44,0	22,0	19,0	135,5	17,0		10/5		
300	750 MCM	750	12 CL750-12	26,0	48,0	22,0	19,0	140,5	13,2	GREEN	10/5		
			16 CL750-58	26,0	48,0	22,0	19,0	140,5	17,0		10/5		

Also available with inspection hole.
In case of order, add suffix IH to the part number.
E.g.: CL250IH-12

COLOUR CODED COPPER CRIMPING LUGS

CL-D

double hole long barrel - for Copper conductors

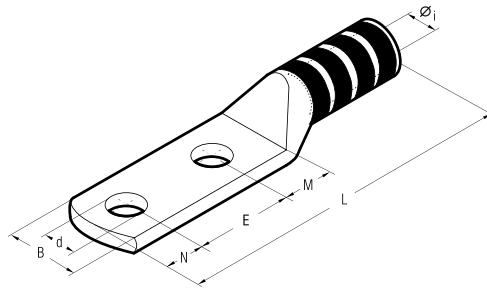

Cond. Size sqmm	Conductor AWG Size	Ø Stud mm	Type	Dimensions mm							Colour Code	Quantity Box/Bag	Mechanical Tools	Hydraulic Tools
				Øi	B	M	E	N	L	d				
10	8	23	6 CL8-D14	4,6	11,0	7,0	16,0	6,0	53,0	6,4	RED	400/50	B15MD	
			6 CL8-D141	4,6	11,0	7,0	19,0	6,0	56,0	6,4	RED	400/50		
			10 CL8-D38	4,6	18,0	11,0	25,5	10,0	70,5	10,5	RED	400/50		
16	6	40	6 CL6-D14	5,8	11,5	7,0	16,0	6,0	54,5	6,4	BLUE	400/50	B15MD	
			6 CL6-D141	5,8	11,5	7,0	19,0	6,0	57,5	6,4	BLUE	400/50		
			10 CL6-D38	5,8	18,0	11,0	25,5	10,0	72,0	10,5	BLUE	400/50		
25	4	40	6 CL4-D14	6,2	12,5	7,0	16,0	6,0	62,0	6,4	GREY	200/50	B15MD	
			6 CL4-D141	6,2	12,5	7,0	19,0	6,0	65,0	6,4	GREY	200/50		
			10 CL4-D38	6,2	18,0	11,0	25,5	10,0	79,5	10,5	GREY	200/50		
3	50	75	6 CL3-D14	7,0	18,0	11,0	25,5	10,0	79,5	10,5	WHITE	200/50	B15MD	
			12 CL3-DN	7,0	21,0	14,0	44,5	12,0	103,5	13,2	WHITE	200/50		
			6 CL2-D14	7,6	17,0	7,0	16,0	6,0	61,0	6,4	BROWN	200/50		
35	2	60	6 CL2-D141	7,6	17,0	7,0	19,0	6,0	64,0	6,4	BROWN	200/50	B15MD	
			10 CL2-D38	7,6	19,0	11,0	25,5	10,0	78,5	10,5	BROWN	100/50		
			12 CL2-DN38	7,6	19,0	11,0	44,5	10,0	97,5	10,5	BROWN	100/50		
1	75	100	6 CL1-D14	8,9	17,0	7,0	16,0	6,0	63,0	6,4	GREEN	200/50	B15MD	
			6 CL1-D141	8,9	17,0	7,0	19,0	6,0	66,0	6,4	GREEN	200/50		
			10 CL1-D38	8,9	19,0	11,0	25,5	10,0	80,5	10,5	GREEN	100/25		
50	1/0	100	12 CL1-DN	8,9	21,0	14,0	44,5	12,0	104,5	13,2	GREEN	100/25	B15MD	
			6 CL1/0-D14	10,0	19,0	7,9	16,0	7,0	68,0	6,4	PINK	100/25		
			6 CL1/0-D141	10,0	19,0	7,9	19,0	7,0	71,0	6,4	PINK	100/25		
70	2/0	125	10 CL1/0-D38	10,0	20,0	10,9	25,5	10,0	83,5	10,5	PINK	100/25	B15MD	
			12 CL1/0-DN	10,0	21,0	14,0	44,5	12,0	107,5	13,2	PINK	100/25		
			6 CL2/0-D14	11,3	21,0	7,8	16,0	7,0	76,0	6,4	BLACK	60/30		
95	3/0	150	6 CL2/0-D141	11,3	21,0	7,8	19,0	7,0	79,0	6,4	BLACK	60/30	B15MD	
			10 CL2/0-D38	11,3	21,0	11,0	25,5	10,0	91,5	10,5	BLACK	60/30		
			12 CL2/0-DN	11,3	22,0	14,0	44,5	12,0	115,5	13,2	BLACK	60/30		
120	MCM	250	6 CL3/0-D141	12,4	23,3	8,0	19,0	7,0	82,0	6,4	ORANGE	60/30	B15MD	
			10 CL3/0-D38	12,4	23,3	11,0	25,5	10,0	94,5	10,5	ORANGE	60/30		
			12 CL3/0-DN	12,4	24,0	14,0	44,5	12,0	118,5	13,2	ORANGE	60/30		
150	MCM	300	6 CL4/0-D141	13,5	25,0	13,0	19,0	11,0	94,0	6,4	PURPLE	50/25	B15MD	
			10 CL4/0-D38	13,5	25,0	11,0	25,5	10,0	97,5	10,5	PURPLE	50/25		
			12 CL4/0-DN38	13,5	25,0	11,0	44,5	10,0	116,5	10,5	PURPLE	50/25		
185	MCM	350	10 CL4/0-DN	13,5	25,0	14,0	44,5	12,0	121,5	13,2	PURPLE	50/25	B15MD	
			6 CL250-D38	15,2	28,5	11,0	25,5	10,0	103,0	10,5	YELLOW	40/20		
			12 CL250-DN	15,2	28,5	14,0	44,5	12,0	127,0	13,2	YELLOW	40/20		
240	MCM	400	10 CL300-D38	16,7	31,5	13,0	25,5	11,0	116,0	10,5	WHITE	30/15	B15MD	
			12 CL300-DN	16,7	31,5	16,0	44,5	14,0	141,0	13,2	WHITE	30/15		
			6 CL350-D141	17,6	33,0	13,0	19,0	11,0	109,5	6,4	RED	30/15		
300	MCM	500	10 CL350-D38	17,6	33,0	13,0	25,5	11,0	116,0	10,5	RED	30/15	B15MD	
			12 CL350-DN	17,6	33,0	16,0	44,5	14,0	141,0	13,2	RED	30/15		
			6 CL400-D141	19,2	35,5	13,0	19,0	11,0	118,5	6,4	BLUE	20/10		
300	MCM	600	10 CL400-D38	19,2	35,5	13,0	25,5	11,0	125,0	10,5	BLUE	20/10	B15MD	
			12 CL400-DN	19,2	35,5	16,0	44,5	14,0	150,0	13,2	BLUE	20/10		
			6 CL500-D141	21,1	39,0	13,0	19,0	11,0	119,5	6,4	BROWN	20/10		
300	MCM	750	10 CL500-D38	21,1	39,0	13,0	25,5	11,0	126,0	10,5	BROWN	10/5	B15MD	
			12 CL500-DN	21,1	39,0	16,0	44,5	14,0	151,0	13,2	BROWN	10/5		
			10 CL600-D38	23,7	44,0	20,0	25,5	11,0	149,5	10,5	GREEN	20/5		
300	MCM	750	12 CL600-DN	23,7	44,0	20,0	44,5	14,0	171,5	13,2	GREEN	20/5	B15MD	
			10 CL750-DN38	26,0	48,0	20,0	44,5	11,0	173,5	10,5	BLACK	15/5		
			10 CL750-D38	26,0	48,0	20,0	25,5	11,0	154,5	10,5	BLACK	15/5		
300	MCM	750	12 CL750-DN	26,0	48,0	20,0	44,5	14,0	176,5	13,2	BLACK	15/5	B15MD	

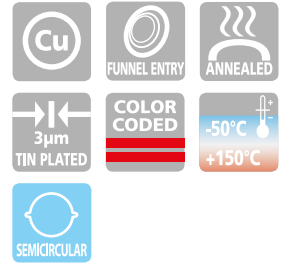

CL series lugs are manufactured from electrolytic Copper tube with a purity greater than 99.9%.

The dimensions of the tube are designed to obtain the most efficient electrical conductivity and mechanical strength to resist vibration and pull out.

CEMBRE lugs are annealed to guarantee optimum ductility, an absolute necessity for connectors which will have to withstand the severe deformation arising when compressed and any bending of the palm during installation.

In applications subject to vibration, terminals have to perform a reliable connection, the annealing process plays a vital role in avoiding cracking or breaks between the barrel and palm.

The barrel length has been designed to allow easy and accurate positioning of the dies during the crimping operation.

Lugs are electrolytically Tin plated to avoid oxidation.

The tongue is clearly marked with wire size and die index for CEMBRE tools.

UL listed for US and Canada per UL486A up to 35 KV.

CL series lugs are an important part of CEMBRE crimping systems for power carrying conductors.

Details of the appropriate crimping tools and dies are shown on page 321.

CEMBRE technicians are available to provide technical advice as required.

Please consult CEMBRE for products not listed.

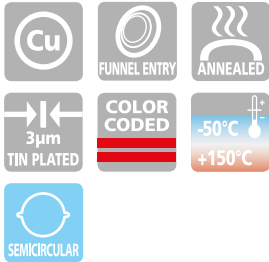
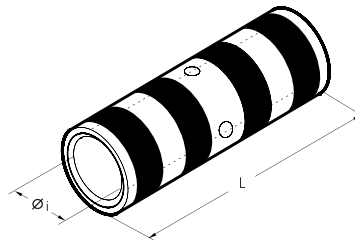

BSCL range of connectors are designed for joining low voltage conductors in heavy duty applications. Made of electrolytic Copper tube with a purity greater than 99.9%, having the same dimension as C and CL series lugs, BSCL connectors are annealed and electrolytically Tin plated.

They feature an internal taper at both ends to ease the introduction of the conductor and a central stop to ensure correct positioning. **UL listed for US and Canada per UL486A up to 35 KV.**

Appropriate crimping tools and dies are shown in details on page 321.

Conductor Size sqmm (AWG)	Conductor Size AWG	Type	Dimensions mm		Colour Code	Quantity Box/Bag	Mechanical Tools			Hydraulic Tools					
			ø1	L			HN1	HN5	TN70	TN120S	B15MD	HT51 RH50 B500ND	HTT120 and tools and heads with 130 kN crimping force	ECW-HBD RHU520	
10	8	BSCL8	4,6	50,5	RED	600/150									
16	6	BSCL6	5,8	50,5	BLUE	400/100									
25	4	BSCL4	6,2	60,5	GREY	200/100									
	3	BSCL3	7,0	60,5	WHITE	200/50									
35	2	BSCL2	7,6	60,5	BROWN	200/50									
	1	BSCL1	8,9	65,5	GREEN	200/50									
50	1/0	BSCL1/0	10,0	73,0	PINK	200/50									
70	2/0	BSCL2/0	11,3	79,0	BLACK	100/50									
95	3/0	BSCL3/0	12,4	79,0	ORANGE	80/40									
	4/0	BSCL4/0	13,5	85,5	PURPLE	50/25									
120	250 MCM	BSCL250	15,2	85,5	YELLOW	50/25									
150	300 MCM	BSCL300	16,7	104,5	WHITE	40/20									
185	350 MCM	BSCL350	17,6	104,5	RED	40/20									
	400 MCM	BSCL400	19,2	111,0	BLUE	20/10									
240	500 MCM	BSCL500	21,1	117,0	BROWN	20/10									
300	600 MCM	BSCL600	23,7	139,5	GREEN	20/10									
	750 MCM	BSCL750	26,0	149,0	BLACK	10/10									

SLEEVE CONNECTORS

for Copper conductors

C-C

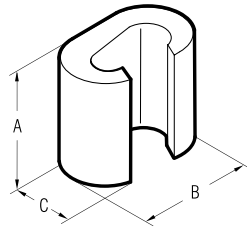

tin plated version

Conductor Size sqmm		Type	Dimensions mm			Quantity Box/Bag	Mechanical Tools	Hydraulic Tools		
Run	Tap		A	B	C			HT45-E B450ND-BV HT45-E B500 B500ND HT51 RH50 RHU81	HT81-U RHU81	ECW-H3D
6÷2,5	6÷1,5	C6-C6ST*	9,0	9,8	6,4	1.000/100	HP4-C10			
10	10÷1,5	C10-C10ST*	12,0	12,6	8,4	500/100				
16	16÷1,5	C16-C16ST	17,0	19,4	12,0	500/100				
25÷16	10÷1,5	C25-C10ST	17,0	19,8	13,0	400/50				
25	25÷16	C25-C25ST	17,0	21,4	13,0	300/50				
40÷35	16÷1,5	C35-C16ST	21,0	24,6	15,4	200/25				
40÷35	40÷25	C35-C35ST	21,0	26,6	15,6	200/25				
50	25÷10									
70÷63	25÷1,5	C70-C25N-ST	21,0	26,4	17,5	200/50				
50	25÷4	C50-C25ST	25,0	32,9	21,0	100/25				
50	50÷35	C50-C50ST	26,0	33,0	21,0	100/25				
70÷50	40÷4	C70-C35ST	28,0	33,0	21,0	100/25				
70÷50	70÷35	C70-C70ST	28,0	34,0	21,0	100/25				
100÷95	40÷4	C95-C35ST	29,0	40,6	26,0	50/25				
100÷95	70÷40	C95-C70ST	29,0	41,0	26,0	50/25				
100÷95	100÷63	C95-C95ST	29,0	41,0	26,0	50/25				
125÷110	125÷25	C120-C120ST	30,0	45,0	28,0	30/15				
160÷150	125÷25	C150-C120ST	31,0	45,0	28,0	50/25				
125	125									
150	150÷63	C150-C150ST	30,0	45,0	28,0	50/25				
125	125									
185	100÷16	C185-C95ST	31,0	45,0	28,0	30/15				
185÷120	185÷120	C185-C185ST	22,6	68,0	34,0	30/15				
240÷150	120÷95	C240-C120ST	22,6	68,0	34,0	30/15				

*Given the small size, on these connectors, only the type is engraved

bright surface version

Conductor Size sqmm		Type	Dimensions mm			Quantity Box/Bag	Mechanical Tools	Hydraulic Tools		
Run	Tap		A	B	C			HT45-E B450ND-BV HT45-E B500 B500ND HT51 RH50 RHU81	HT81-U RHU81	ECW-H3D
6÷2,5	6÷1,5	C6-C6*	9,0	9,8	6,4	1.000/100	HP4-C10			
10	10÷1,5	C10-C10*	12,0	12,6	8,4	500/100				
16	16÷1,5	C16-C16	17,0	19,4	12,0	500/100				
25÷16	10÷1,5	C25-C10	17,0	19,8	13,0	400/50				
25	25÷16	C25-C25	17,0	21,4	13,0	300/50				
40÷35	16÷1,5	C35-C16	21,0	24,6	15,4	200/25				
40÷35	40÷25	C35-C35	21,0	26,6	15,6	200/25				
50	25÷10									
70÷63	25÷1,5	C70-C25N	21,0	26,4	17,5	200/25				
50	25÷4	C50-C25	25,0	32,9	21,0	100/25				
50	50÷35	C50-C50	26,0	33,0	21,0	100/25				
70÷50	40÷4	C70-C35	28,0	33,0	21,0	100/25				
70÷50	70÷35	C70-C70	28,0	34,0	21,0	100/25				
100÷95	40÷4	C95-C35	29,0	40,6	26,0	50/25				
100÷95	70÷40	C95-C70	29,0	41,0	26,0	50/25				
100÷95	100÷63	C95-C95	29,0	41,0	26,0	50/25				
125÷110	125÷25	C120-C120	30,0	45,0	28,0	30/15				
160÷150	125÷25	C150-C120	31,0	45,0	28,0	30/15				
125	125									
150	150÷63	C150-C150	30,0	45,0	28,0	30/15				
125	125									
185	100÷16	C185-C95	31,0	45,0	28,0	30/15				
185÷120	185÷120	C185-C185	22,6	68,0	34,0	30/15				
240÷150	120÷95	C240-C120	22,6	68,0	34,0	30/15				

*Given the small size, on these connectors, only the type is engraved

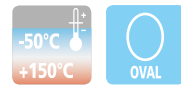

"C" connectors are manufactured from Copper profiles with a purity greater than 99.9%, and are suitable for a variety of uses either to create an earthing network or tapping off from overhead distribution lines. Each connector is marked as follows:

- CEMBRE trade mark
- Reference number
- Conductor size-Run
- Conductor size-Tap
- Number of crimps
- Die reference.

Details of the appropriate crimping tools and dies are shown on page 316.



Example of tap connection

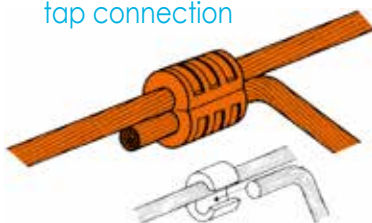

Example of joint connection

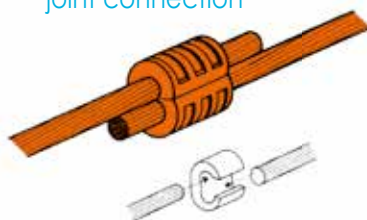

Example of joining two running conductors

Conductor Size sqmm	Type
25-25	C35-C16
35-35	C35-C35
50-50	C70-C70
63-63	C95-C70
70-70	
95-95	C150-C120
120-120	C150-C150
120-120	C185-C95
125-125	

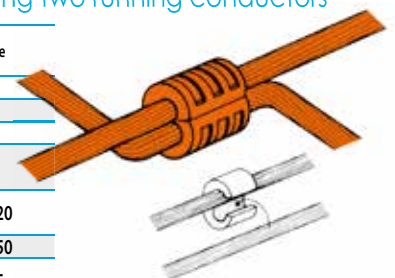

H-H

H CLAMPS

for Copper conductors

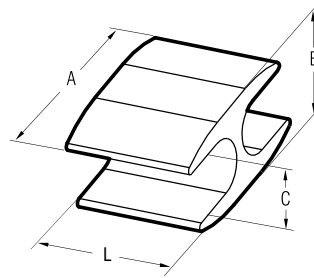

tin plated version

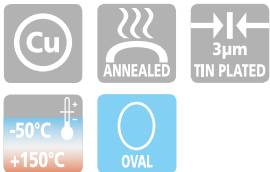

Conductor Size mm ²		Type	Dimensions mm				Quantity	Hydraulic Tools			
Run	Tap		A	B	C	L		HT120 and tools and heads with 130 kN crimping force	ECW-H3D	RHU450	RHU520
70	70	H70-H70ST	34,0	17,0	10,8	28,0	25				
95	95	H95-H95ST	40,0	22,0	13,0	30,0	25				
120	120	H120-H120ST	43,0	24,0	15,5	25,0	15				

bright surface version



Conductor Size mm ²		Type	Dimensions mm				Quantity	Hydraulic Tools			
Run	Tap		A	B	C	L		HT120 and tools and heads with 130 kN crimping force	ECW-H3D	RHU450	RHU520
70	70	H70-H70	34,0	17,0	10,8	28,0	25				
95	95	H95-H95	40,0	22,0	13,0	30,0	25				
120	120	H120-H120	43,0	24,0	15,5	25,0	15				

H clamps are manufactured from Copper profiles with a purity greater than 99.9%, and are suitable for a earthing systems.

Each connector is marked as follows:

- CEMBRE trade mark
- Reference number

features:

- H shape
- For Copper conductors DIN 48201
- Material: Cu ETP (CW004A) according to EN 13605
- Surface: bright and tin plated version
- Electrolytically tin plated to avoid oxidation; min 3µm

Details of the appropriate crimping tools and dies are shown on page 316.

TWIN CABLE TERMINAL LUGS FOR ROUND CONDUCTORS

DK

for Copper conductors

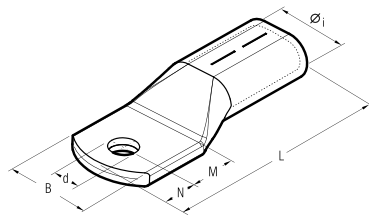

with an M12 hole

Conductor Size mm ²	Type	Dimensions mm						Quantity	Hydraulic Tools
		Øi	B	M	N	L	d		
2 x 50	DK50-M12	20,6x10,75	34,0	22,0	14,5	93,5	13,0	10	HT120 and tools and heads with 130 kN crimping force ECW-H3D RHU450 RHU520
2 x 70	DK70-M12	23,0x12,0	37,0	22,0	14,5	97,5	13,0	10	
2 x 95	DK95-M12	26,5x12,8	42,0	23,0	16,0	108,0	13,0	10	
2 x 120	DK120-M12	29,5x15,5	48,0	24,0	14,5	115,5	13,0	5	

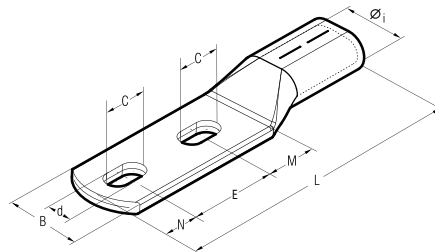
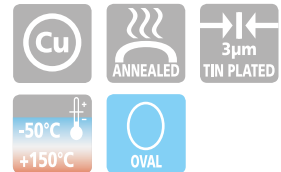

with 2 elongated holes

Conductor Size mm ²	Type	Dimensions mm								Quantity	Hydraulic Tools
		Øi	B	M	N	E	L	C	d		
2 x 70	DK70-2M12-51AS	23,0x12,0	37,0	25,5	21,5	51,0	159,0	24,0	13,0	10	HT120 and tools and heads with 130 kN crimping force ECW-H3D RHU450 RHU520
2 x 95	DK95-2M12-51AS	26,5x12,8	42,0	25,5	21,5	51,0	167,0	24,0	13,0	10	
2 x 120	DK120-2M12-51AS	29,5x15,5	48,0	25,5	21,5	51,0	175,0	24,0	13,0	10	

DK compression cable lugs are made from Copper tube with a purity greater than 99.9% and are suitable for the compression of 2 round conductors.

Cable lugs with an M12 hole or with 2 elongated holes are available (see tables). The elongated holes 2xM12 allow easy assembly with different fastening points. This enables flexible use in earthing systems.

features:

- For copper conductors DIN 48201
- Material: Cu ETP (CW004A) according to EN13605
- Electrolytically tin plated to avoid oxidation; min 3µm
- Marking: CEMBRE logo; Type, die type (MRD ..- C); Press positions

Details of the appropriate crimping tools and dies are shown on page 316.

for Copper conductors

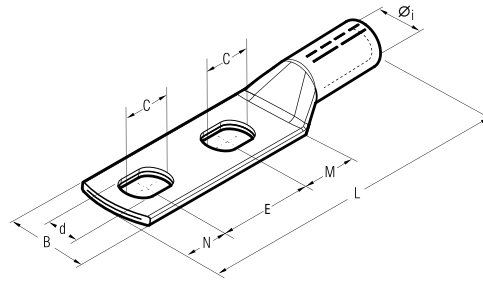

with 2 elongated holes



Conductor Size sqmm	Type	Dimensions mm								Quantity	Mechanical Tools	Hydraulic Tools								
		Øi	B	M	N	E	L	C	d											
70	DR70-2M12-51AS	11,5	24,0	25,5	21,5	51,0	140,0	24,0	13,0	10	TNE-D50	TNE-D120	HT45-E	B450ND-BV	B500ND	B600CND	B600CND	HT120 and tools and heads with 130 kN crimping force	ECW-H3D	RHU520
95	DR95-2M12-51AS	13,5	28,0	25,5	21,5	51,0	150,0	24,0	13,0	10	TNE-D120		HT45-E	B450ND-BV	B500ND	B600CND	B600CND		ECW-H3D	RHU520
120	DR120-2M12-51AS	15,5	32,0	25,5	21,5	51,0	151,0	24,0	13,0	10	TNE-D120		HT45-E	B450ND-BV	B500ND	B600CND	B600CND		ECW-H3D	RHU520

DR compression cable lugs are made from Copper tube with a purity greater than 99.9%. They are available with 2 slotted holes (see tables). The slotted holes 2xM12 enable easy installation with different attachment points.

features:

- For copper conductors DIN 48201
- Material: Cu ETP (CW004A) according to EN13605
- Electrolytically tin plated to avoid oxidation; min 3µm
- Marking: CEMBRE logo; Type, die type (MK.); Press positions

Details of the appropriate crimping tools and dies are shown on page 316.

MECHANICAL FIXING LUGS

21..

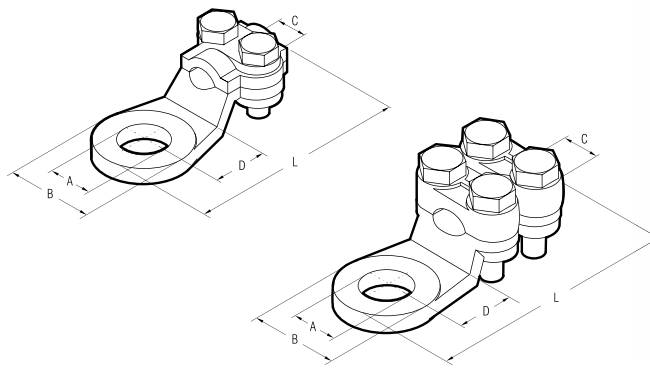

2 bolt fixing lugs

Conductor Size sqmm	Type	Clamping Bolt		Ø A Bolt	Dimensions mm				Quantity
		Ø	Torque Ratio Nm		B	C	D	L	
16	2155	M5	3	M8	18,0	4,5	12,5	39	100
16	2171	M5	3	M10	18,0	4,5	12,5	39	100
25	2156	M5	3	M8	19,5	6,0	13,0	43	100
25	2172	M5	3	M10	19,5	6,0	13,0	43	100
35	2157	M5	3	M12	23,0	7,0	15,0	49	50
35	2173	M5	3	M14	23,0	7,0	15,0	49	50
50	2174	M6	5	M14	25,0	8,0	17,0	56	50



Material:
Brass CB754S EN 1982 Nickel plated.
Zinc plated Steel bolts.

4 bolt fixing lugs

Conductor Size sqmm	Type	Clamping Bolt		Ø A Bolt	Dimensions mm				Quantity
		Ø	Torque Ratio Nm		B	C	D	L	
50	2158	M6	5	M12	23,5	8	16,0	57	50
75	2160	M6	5	M12	28,0	10	20,0	65	25
75	2176	M6	5	M16	28,0	10	20,0	65	25
100	2161*	M6	5	M12	31,0	13	17,0	66	25
125	2162*	M7	10	M15	33,0	14	18,0	71	25
150	2163*	M7	10	M14	34,0	16	19,5	75	25
175	2164*	M7	10	M15	36,0	16	21,0	78	25



* Versions with U-bolts in bent steel

CABLE CLAMPS

23..

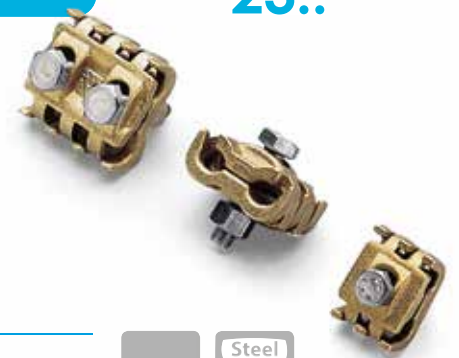
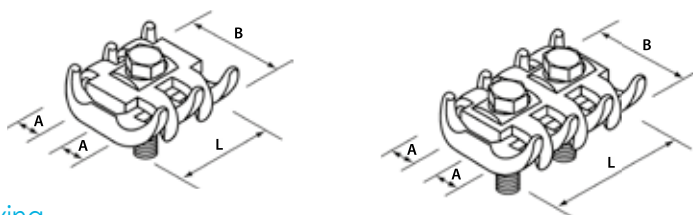

Single bolt fixing

Conductor Size sqmm	Type	Clamping Bolt		A for Cable mm	Dimensions mm		Quantity
		Ø	Torque Ratio Nm		B	L	
6÷16	2323	M6	8	3÷ 5	24	20,0	50
16÷50	2326	M8	15	5÷ 8	32	28,4	50
35÷70	2329	M8	15	7÷12	40	30,0	25



2 bolt fixing

Conductor Size sqmm	Type	Clamping Bolt		A for Cable mm	Dimensions mm		Quantity
		Ø	Torque Ratio Nm		B	L	
6÷16	2333	M6	8	3÷ 5	24,5	30	50
16÷50	2336	M8	15	5÷ 8	32,0	40	50
35÷70	2339	M8	15	7÷12	40,0	44	25
50÷95	2342	M10	35	8÷14	48,0	48	10
95÷150	2344	M10	35	12÷16	51,0	53	10
150÷300	2346*	M12	60	16÷22	66,0	66	5

Material:
Brass CB754S EN 1982
White zinc plated Steel bolts.
White zinc plated Steel nuts.

* Stainless Steel bolts

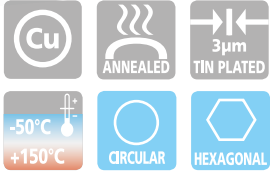
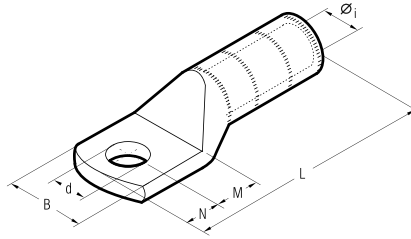

Series CA-M and 2A-M terminals are designed for medium voltage applications up to 35 kV. They are manufactured from Copper tube with a purity greater than 99.9%, annealed and Tin plated. The extended barrel enhances both electrical and mechanical performance. The absence of an inspection hole prevents moisture entry into the crimped joint and makes these terminals suitable for outdoor applications. Details of the appropriate crimping tools and dies are shown on page 317.

Conductor Size (sqmm) & Format	Ø Stud mm	Type	Dimensions mm						Quantity Box/Bag	Hydraulic Tools
			Øi	B	M	N	L	d		
25 R/BR/BS*	8	CA25-M8	6,8	14,0	9,0	8,0	65,0	8,4	300/50	HT45-E B450ND-BV HT51 RH50 B500 B500ND HT81-U RHU81 HT120 and tools and heads with 130 kN crimping force ECW-H3D RHU520
	10	CA25-M10	6,8	18,0	13,0	11,0	72,0	10,5	200/50	
	12	CA25-M12	6,8	21,0	16,0	14,0	78,0	13,2	150/50	
30 RC/S ÷ 40 S	12	CA40S-M12	8,2	21,0	16,0	14,0	79,0	13,2	100/50	
	16	CA40S-M16	8,2	26,0	19,0	17,0	85,0	17,0	100/50	
35 BR/BS*	10	CA35-M10	8,3	21,0	13,0	11,0	73,0	10,5	150/50	
	12	CA35-M12	8,3	21,0	16,0	14,0	79,0	13,2	150/50	
	16	CA35-M16	8,3	26,0	19,0	17,0	85,0	17,0	150/50	
50 RC	12	CA50R-M12	8,7	20,5	16,0	14,0	79,0	13,2	100/50	
50 S	12	CA50S-M12	9,5	21,0	16,0	14,0	79,0	13,2	100/50	
	16	CA50S-M16	9,5	26,0	19,0	17,0	85,0	17,0	100/50	
50 BR/BS*	10	CA50-M10	9,5	21,0	13,0	11,0	73,0	10,5	150/50	
	12	CA50-M12	9,5	21,0	16,0	14,0	79,0	13,2	150/50	
	14	CA50-M14	9,5	25,0	18,0	16,0	83,0	15,0	100/50	
	16	CA50-M16	9,5	26,0	19,0	17,0	85,0	17,0	100/50	
63 S ÷ 70 S	12	CA70S-M12	11,0	28,0	16,0	14,0	81,2	13,2	30/15	
	16	CA70S-M16	11,0	30,0	19,0	17,0	87,2	17,0	50/25	
70 BR/BS*	10	CA70S-M10	11,0	26,0	13,0	11,0	75,2	10,5	50/25	
	12	CA70S-M12	11,0	28,0	16,0	14,0	81,2	13,2	30/15	
	14	CA70S-M14	11,0	28,0	18,0	16,0	85,2	15,0	50/25	
	16	CA70S-M16	11,0	30,0	19,0	17,0	87,2	17,0	50/25	
80 S ÷ 95 RC	12	CA95R-M12	12,0	28,0	16,0	14,0	91,0	13,2	30/15	
	14	CA95R-M14	12,0	29,0	18,0	16,0	95,0	15,0	50/25	
95 S ÷ 100 S	12	CA95S-M12	13,5	28,0	16,0	14,0	91,0	13,2	30/15	
	14	CA95S-M14	13,5	29,0	18,0	16,0	94,5	15,0	50/25	
	16	CA95S-M16	13,5	30,0	20,0	17,0	97,0	17,0	50/25	
95 BR/BS*	10	CA95-M10	13,5	28,0	13,0	11,0	85,0	10,5	50/25	
	12	CA95-M12	13,5	28,0	16,0	14,0	91,0	13,2	50/25	
	16	CA95-M16	13,5	30,0	20,0	17,0	97,0	17,0	50/25	
	120 RC/S ÷ 150 RC	12	CA150R-M12	15,0	31,0	16,0	14,0	97,0	13,2	
	14	CA150R-M14	15,0	31,0	18,0	16,0	101,0	15,0	30/15	
	120 BR/BS*	12	CA120-M12	15,0	31,0	16,0	14,0	97,0	13,2	30/15
16		CA120-M16	15,0	31,0	19,0	17,0	103,0	17,0	30/15	
150 S ÷ 160 RC	12	CA150S-M12	16,5	32,0	16,0	14,0	97,0	13,2	30/15	
	14	CA150S-M14	16,5	32,0	18,0	16,0	101,0	15,0	30/15	
150 BR/BS*	12	CA150-M12	16,5	32,0	16,0	14,0	97,0	13,2	30/15	
	16	CA150-M16	16,5	32,0	19,0	17,0	103,0	17,0	30/15	
160 S ÷ 200 RC	14	CA200R-M14	17,0	32,5	18,0	16,0	101,0	15,0	30/15	
185 BR/BS*	12	CA185-M12	18,0	33,5	16,0	14,0	97,0	13,2	30/15	
	16	CA185-M16	18,0	33,5	19,0	17,0	103,0	17,0	30/15	
200 S ÷ 240 RC	14	CA240R-M14	19,2	43,0	18,0	16,0	107,0	15,0	15/5	
240 S ÷ 315 RC	14	CA315R-M14	21,5	43,0	18,0	16,0	105,0	15,0	15/5	
	12	CA240-M12	20,5	42,0	16,0	14,0	103,0	13,2	15/5	
240 BR/BS*	16	CA240-M16	20,5	42,0	19,0	17,0	109,0	17,0	15/5	
	20	CA240-M20	20,5	42,0	22,0	20,0	115,0	21,0	15/5	
300 BR/BS*	12	CA300-M12	23,0	43,5	16,0	14,0	109,5	13,2	15/5	
	16	CA300-M16	23,0	43,5	19,0	17,0	115,5	17,0	15/5	
	20	CA300-M20	23,0	43,5	22,0	20,0	121,5	21,0	15/5	
315 S	14	CA315S-M14	23,7	44,0	18,0	16,0	105,0	15,0	15/5	

Conductor Format: R = Round, RC = Round Compact, S = Sector, BR = BS EN 60228 Round, BS* = BS EN 60228 size - Sector shaped
* = Pre-rounding required, consult CEMBRE for appropriate die set

MEDIUM VOLTAGE COPPER TERMINALS

CA-2M

two hole fixing

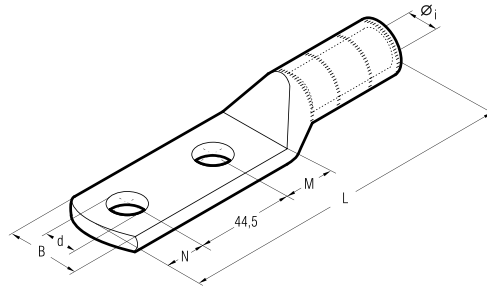

Conductor Size (sqmm) & Format	Ø Stud mm	Type	Dimensions mm						Quantity Box/Bag	Hydraulic Tools	
			Øi	B	M	N	L	d			
25 R	8	CA25-2M8	6,8	14,0	10,0	11,0	113,5	8,4	200/50	HT45-E B450ND-BV	
	12	CA25-2M12	6,8	21,0	16,0	14,0	122,5	13,2	100/50		
25 BR/BS*	8	CA25-2M8	6,8	14,0	10,0	11,0	113,5	8,4	200/50	HT45-E B500ND B550	
	10	CA25-2M10	6,8	18,0	13,0	11,0	116,5	10,5	150/50		
30 RC/S ÷ 40 S	12	CA40S-2M12	8,2	21,5	16,0	14,0	123,5	13,2	100/50	HT81-U RHU81	
		CA35-2M12	8,3	21,5	16,0	14,0	123,5	13,2	100		
50 RC	12	CA50R-2M12	8,7	20,5	16,0	14,0	123,5	13,2	100/50	HT51 RH50 B500 B500ND RHU81	
50 S	12	CA50S-2M12	9,5	21,0	16,0	14,0	123,5	13,2	100/50		
50 BR/BS*	12	CA50-2M12	9,5	21,0	16,0	14,0	123,5	13,2	90/3	HT51 RH50 B500 B500ND RHU81	
63 S ÷ 70 S	12	CA70S-2M12	11,0	27,0	16,0	14,0	125,5	13,2	50/25		
70 BR/BS*	12	CA70S-2M12	11,0	27,0	16,0	14,0	125,5	13,2	50/25	HT51 RH50 B500 B500ND RHU81	
80 S ÷ 95 RC	14	CA95R-2M14	12,0	28,0	18,0	16,0	139,5	15,0	30/15		
95 S ÷ 100 S	14	CA95S-2M14	13,5	29,0	18,0	16,0	139,5	15,0	30/15	HT51 RH50 B500 B500ND RHU81	
95 BR/BS*	12	CA95-2M12	13,5	28,0	16,0	14,0	135,5	13,2	30/15		
120 RC/S ÷ 150 RC	14	CA150R-2M14	15,0	31,0	18,0	16,0	145,5	15,0	30/15	HT51 RH50 B500 B500ND RHU81	
120 BR/BS*	12	CA120-2M12	15,0	31,0	16,0	14,0	141,5	13,2	30/15		
150 S ÷ 160 RC	14	CA150S-2M14	16,5	32,0	18,0	16,0	145,5	15,0	30/15	HT51 RH50 B500 B500ND RHU81	
150 BR/BS*	12	CA150-2M12	16,5	32,0	16,0	14,0	141,5	13,2	30/15		
160 S ÷ 200 RC	14	CA200R-2M14	17,0	32,5	18,0	16,0	145,0	15,0	30/15	HT51 RH50 B500 B500ND RHU81	
185 BR/BS*	12	CA185-2M12	18,0	32,5	16,0	14,0	141,5	13,2	30/15		
200 S ÷ 240 RC	14	CA240R-2M14	19,2	43,0	18,0	16,0	151,5	15,0	15/5	HT51 RH50 B500 B500ND RHU81	
240 S ÷ 315 RC	14	CA315R-2M14	21,5	43,0	18,0	16,0	149,5	15,0	20/5		
240 BR/BS*	12	CA240-2M12	20,5	43,0	16,0	14,0	147,5	13,2	15/5	HT51 RH50 B500 B500ND RHU81	
300 BR/BS*	12	CA300-2M12	23,0	43,0	16,0	14,0	145,5	13,2	15/5		
315 S	14	CA315S-2M14	23,7	44,0	18,0	16,0	149,5	15,0	20/5	HT120 and tools and heads with 130 kN crimping force	ECW-H3D RHU520

Conductor Format: R = Round, RC = Round Compact, S = Sector, BR = BS EN 60228 Round, BS* = BS EN 60228 size - Sector shaped
 * = Pre-rounding required, consult CEMBRE for appropriate die set

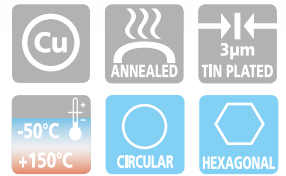

CA-2M and 2A-2M Copper Tube Terminal Lugs are designed for medium voltage applications up to 35 kV. Manufactured from Copper tube with a purity greater than 99.9%, annealed and Tin plated. The extended barrel enhances electrical and mechanical performance.

The absence of an inspection hole prevents moisture entry into the crimped joint. Featuring an extended palm with two fixing holes at 44.5 mm centres.

Details of the appropriate crimping tools and dies are shown on page 317.

MEDIUM VOLTAGE COPPER TERMINALS

2A-2M/55°

palm bent at 55° - two hole fixing

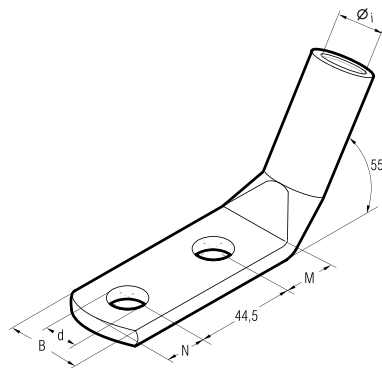

Conductor Size sqmm	Ø Stud mm	Type	Dimensions mm						Quantity Box/Bag	Hydraulic Tools	
			Øi	B	M	N	d				
400 R	14	2A80-2M14/55	27,0	51,0	22	16	15	10/5	HT120 and tools and heads with 130 kN crimping force	ECW-H3D RHU520	
600 R ÷ 630 R	14	2A120-2M14/55	33,4	61,5	22	16	15	15/3			

R = Round conductors



The 2A-2M/55° Copper Tube Terminal Lugs have the same characteristics as the CA-2M and 2A-2M ranges, with the additional feature of the palm bent at 55°.

Details of the appropriate crimping tools and dies are shown on page 317.

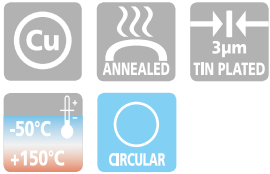
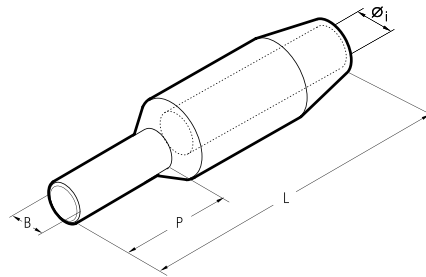

MT-C series connectors are designed for medium voltage applications up to 35 kV.

They are manufactured from Copper with a purity greater than 99.9%, annealed and Tin plated.

The extended barrel enhances both electrical and mechanical performance.

The stalk or pin makes these connectors ideal for terminating conductors into contact blocks.

Details of the appropriate crimping tools and dies are shown on page 317.

Conductor Size (sqmm) & Format	Type	Dimensions mm				Quantity Box/Bag	Hydraulic Tools																																																	
		Øi	B	P	L																																																			
25 R	MT25-C8	6,8	8,0	35,0	80,0	90/3	HT45-E	B450ND-BV																																																
	MT40S-C8	8,2	8,0	35,0	80,0	90/3																																																		
30 RC/S ÷ 40 S	MT40S-C10	8,2	10,0	35,0	80,0	90/3						HT51	RH50	B500	B500ND	B550																																								
	MT40S-C14-80	8,2	14,0	80,0	123,0	30/3																																																		
35 BR/BS*	MT35-C8	8,2	8,0	35,0	80,0	90/3											HT81-U	RH81																																						
	MT35-C10	8,2	10,0	35,0	80,0	90/3																																																		
50 RC	MT35-C14-80	8,2	14,0	80,0	123,0	30/3																HT120																																		
	MT50R-C8	8,8	8,0	35,0	80,0	90/3																																																		
50 RC	MT50R-C10	8,8	10,0	35,0	80,0	90/3																					HT185																													
	MT50S-C8	9,5	8,0	35,0	80,0	90/3																																																		
50 S	MT50S-C10	9,5	10,0	35,0	80,0	90/3																										HT240																								
	MT50S-C14-80	9,5	14,0	80,0	123,0	30/3																																																		
50 BR/BS*	MT50-C8	9,5	8,0	35,0	80,0	90/3																															HT315																			
	MT50-C10	9,2	10,0	35,0	80,0	90/3																																																		
63 S ÷ 70 S	MT50-C14-80	9,5	14,0	80,0	123,0	90/3																																				HT315S														
	MT70S-C10	11,2	10,0	35,0	90,0	30/3																																																		
70 BR/BS*	MT70-C10	11,2	10,0	35,0	90,0	30/3																																									HT240R									
	MT95R-C10	12,0	10,0	45,0	110,0	60/3																																																		
80 S ÷ 95 RC	MT95R-C12	12,0	12,0	45,0	110,0	60/3																																														HT185-C10				
	MT95S-C10	13,5	10,0	45,0	110,0	60/3																																																		
95 S ÷ 100 S	MT95S-C12	13,5	12,0	45,0	110,0	60/3	HT185-C16																																																	
	MT95S-C14-80	13,5	14,0	80,0	145,0	60/3																																																		
95 BR/BS*	MT95-C10	13,5	10,0	45,0	110,0	60/3						HT240R-C12																																												
	MT95-C12	13,5	12,0	45,0	110,0	60/3																																																		
120 RC/S ÷ 150 RC	MT95-C14-80	13,5	14,0	80,0	145,0	60/3											HT240R-C16																																							
	MT150R-C12	15,0	12,0	45,0	110,0	60/3																																																		
120 BR/BS*	MT150R-C16	15,0	16,0	45,0	110,0	30/3																HT315R-C16																																		
	MT120-C12	15,0	12,0	45,0	110,0	60/3																																																		
150 S ÷ 160 RC	MT120-C16	15,0	16,0	45,0	110,0	60/3																					HT240-C12																													
	MT150S-C12	16,5	12,0	45,0	110,0	60/3																																																		
150 BR/BS*	MT150S-C14-80	16,5	14,0	80,0	145,0	45/3																										HT240-C16																								
	MT150S-C16	16,5	16,0	45,0	110,0	30/3																																																		
150 BR/BS*	MT150-C10	16,5	10,0	45,0	110,0	60/3																															HT315R-C12																			
	MT150-C12	16,5	12,0	45,0	110,0	60/3																																																		
160 S ÷ 200 RC	MT150-C14-80	16,5	14,0	80,0	145,0	45/3																																				HT315R-C16														
	MT150-C16	16,5	16,0	45,0	110,0	60/3																																																		
185 BR/BS*	MT150-C10	16,5	10,0	45,0	110,0	60/3																																									HT240-C12									
	MT200R-C10	17,0	10,0	45,0	110,0	30/3																																																		
200 S ÷ 240 RC	MT200R-C16	17,0	16,0	45,0	110,0	30/3																																														HT240-C16				
	MT185-C10	18,0	10,0	45,0	110,0	30/3																																																		
240 S ÷ 315 RC	MT185-C16	18,0	16,0	45,0	110,0	30/3	HT315R-C16																																																	
	MT240R-C12	19,5	12,0	50,0	115,0	30/3																																																		
240 BR/BS*	MT240R-C16	19,5	16,0	50,0	115,0	30/3						HT240-C12																																												
	MT300-C16	23,0	16,0	50,0	115,0	30/3																																																		
300 BR/BS*	MT300-C16	23,0	16,0	50,0	115,0	30/3											HT240-C16																																							
	MT315S-C16	24,0	16,0	60,0	130,0	30/3																																																		

Conductor Format: R = Round, RC = Round Compact, S = Sector, BR = BS EN 60228 Round, BS* = BS EN 60228 size - Sector shaped
 * = Pre-rounding required, consult CEMBRE for appropriate die set

MEDIUM VOLTAGE COPPER THROUGH CONNECTORS

MT-TD MT-GC

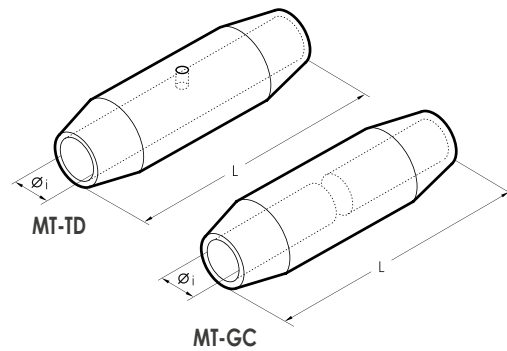

Conductor Size (sqmm) & Format	Type	Type	Dimensions mm		Quantity Box/Bag	Hydraulic Tools			
			ø1	L		HT45-E B450ND-BV	HT51 RH50 B500E B500ND B550	HT81-U RHU81	ECW-H3D RHU520
25 R/BR/BS*	MT25-TD	MT25-GC	6,8	60,0	90/3	HT120 and tools and heads with 130 kN crimping force	ECW-H3D RHU520		
30 RC/S ÷ 40 S	MT40S-TD	MT40S-GC	8,2	60,0	90/3				
30 BR/BS*	MT35-TD	MT35-GC	8,2	60,0	90/3				
50 RC	MT50R-TD	MT50R-GC	8,7	60,0	90/3				
50 S	MT50S-TD	MT50S-GC	9,5	60,0	90/3				
50 BR/BS*	MT50-TD	MT50-GC	9,5	60,0	90/3				
63 S ÷ 70 S	MT70S-TD	MT70S-GC	11,0	70,0	30/3				
70 BR/BS*	MT70-TD	MT70-GC	11,0	70,0	30/3				
80 S ÷ 95 RC	MT95R-TD	MT95R-GC	12,0	80,0	30/3				
95 S ÷ 100 S	MT95S-TD	MT95S-GC	13,5	80,0	30/3				
95 BR/BS*	MT95-TD	MT95-GC	13,5	80,0	30/3				
120 RC/S ÷ 150 RC	MT150R-TD	MT150R-GC	15,0	80,0	30/3				
120 BR/BS*	MT120-TD	MT120-GC	15,0	80,0	30/3				
150 S ÷ 160 RC	MT150S-TD	MT150S-GC	16,5	80,0	30/3				
150 BR/BS*	MT150-TD	MT150-GC	16,5	80,0	30/3				
160 S ÷ 200 RC	MT200R-TD	MT200R-GC	17,0	100,0	30/3				
185 BR/BS*	MT185-TD	MT185-GC	18,0	100,0	30/3				
200 S ÷ 240 RC	MT240R-TD	MT240R-GC	19,2	100,0	21/3				
240 S ÷ 315 RC	MT315R-TD	MT315R-GC	21,5	100,0	21/3				
240 BR/BS*	MT240-TD	MT240-GC	20,5	100,0	30/3				
300 BR/BS*	MT300-TD	MT300-GC	23,0	100,0	30/3				
315 S	MT315S-TD	MT315S-GC	23,7	100,0	21/3				
400 BR/BS*	MT400-TD	MT400-GC	27,0	120,0	15/3				
500 R	MT500-TD		30,3	118,0	12/3				
600 R ÷ 630 R	MT630-TD		33,4	130,0	9/3				

Conductor Format: R = Round, RC = Round Compact, S = Sector, BR = BS EN 60228 Round, BS* = BS EN 60228 size - Sector shaped
* = Pre-rounding required, consult CEMBRE for appropriate die set



MT-TD and MT-GC series connectors are designed to join conductors in medium voltage applications up to 35 kV.

They are manufactured from Copper with a purity greater than 99.9%, annealed and Tin plated.

MT-GC series feature a solid stop which forms a barrier between the two conductors being joined, this prevents the migration of oils or greases, which may be present, in one cable contaminating the other cable.

MT-TD connectors are unblocked and are suitable for joining cables of the same type.

Details of the appropriate crimping tools and dies are shown on page 317.

AA-M

ALUMINIUM TERMINALS

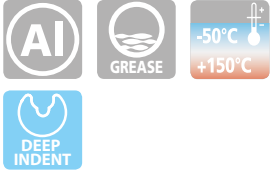
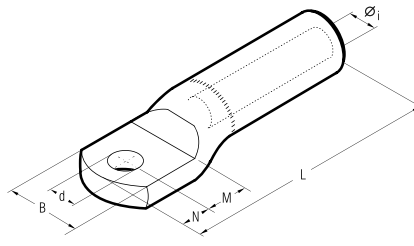

AA-M series terminals are made from Aluminium of a purity equal to or greater than 99,5%. They are designed to accept a variety of conductor forms especially low stranded compacted conductors. Non circular conductors may require pre-rounding prior to introduction to the terminal. Barrels are capped and filled with grease so as to avoid oxidation of the Aluminium. Details of the appropriate crimping tools and dies are shown on page 317, 319.

Conductor Size sqmm	Ø Stud mm	Type	Dimensions mm						Quantity Box/Bag	Hydraulic Tools		
			Øi	B	M	N	L	d				
16	8	AA16-M8	5,5	21	13	11	77,0	8,4	60/3	HT131-UC	RHU131-C	B1300-UC
25	8	AA25-M8	6,5	21	13	11	77,0	8,4	60/3			
35	8	AA35-M8	8,0	23	13	11	77,5	8,4	60/3			
	10	AA35-M10	8,0	23	13	11	77,5	10,5	60/3			
50	12	AA50-M12	9,0	26	16	14	91,0	13,2	60/3			
	14	AA50-M14	9,0	26	18	16	95,0	15,0	60/3			
70	12	AA70-M12	11,0	27	16	14	91,0	13,2	45/3			
	14	AA70-M14	11,0	27	18	16	95,0	15,0	45/3			
95	12	AA95-M12	12,5	27	16	14	91,0	13,2	45/3			
	14	AA95-M14	12,5	27	18	16	95,0	15,0	45/3			
120	12	AA120-M12	13,7	35	16	14	115,0	13,2	30/3			
	14	AA120-M14	13,7	35	18	16	119,0	15,0	30/3			
150	12	AA150-M12	15,5	34	16	14	115,0	13,2	30/3			
	14	AA150-M14	15,5	34	18	16	119,0	15,0	30/3			
185	12	AA185-M12	17,0	42	20	14	122,0	13,2	18/3			
	14	AA185-M14	17,0	42	22	16	126,0	15,0	18/3			
240	12	AA240-M12	19,5	44	20	14	122,0	13,2	15/3			
	14	AA240-M14	19,5	44	22	16	126,0	15,0	15/3			
300	12	AA300-34M12	22,5	47	22	14	130,0	13,2	15/3	HT120	HT131-C	RHC131
	14	AA300-34M14	22,5	47	22	16	132,0	15,0	15/3			
	16	AA300-34M16	22,5	47	22	17	133,0	17,0	15/3			
	16	AA300-M16	23,3	54	22	19	177,0	17,0	12/3			
400	16	AA400-M16	26,0	56	19	17	172,0	17,0	15/3	ECW-H3D	RHU 230-630	
500	16	AA500-40M16	29,1	57	22	19	177,0	17,0	12/3			
630	16	AA630-M16	32,5	70	22	19	177,0	17,0	9/3			



THROUGH CONNECTORS

for Aluminium conductors

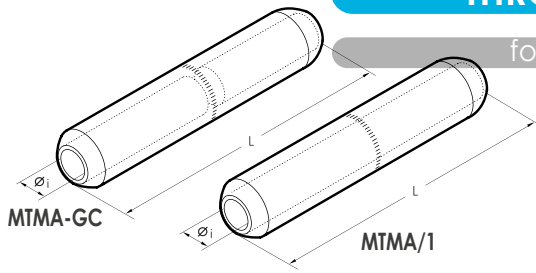

MTMA-GC MTMA/1



Conductor Size sqmm	Type	Type	Dimensions mm		Quantity Box/Bag	Hydraulic Tools	
			\varnothing_i	L			
10	MTMA10-GC		4,3	90,5	60/3	B1300-UC	
16	MTMA16-GC	MTMA16/1	5,5	90,5	60/3		
25	MTMA25-GC	MTMA25/1	6,5	90,5	60/3		
35	MTMA35-GC	MTMA35/1	8,0	90,5	60/3		
	MTMA35-20-GC		8,0	106,5	30/3		
50	MTMA50-GC	MTMA50/1	9,0	106,5	30/3		
70	MTMA70-GC	MTMA70/1	11,0	106,5	30/3		
	MTMA95-GC		12,5	110,0	30/3		
95		MTMA95/1	12,5	106,5	30/3		
	120	MTMA120-GC	13,7	133,0	30/3		
150	MTMA150-GC		15,5	135,0	30/3		
		MTMA150/1	15,5	133,5	30/3		
185	MTMA185-GC	MTMA185/1	17,0	143,5	15/3		
240	MTMA240-GC	MTMA240/1	19,5	143,5	15/3		
	MTMAD300-GC		22,5	144,5	15/3		
300		MTMAD300/1	22,5	135,0	15/3		
	MTMA300-GC		23,3	218,0	15/3		
400		MTMA400/1	26,0	218,0	15/3		
500	MTMA500-GC		29,1	218,5	12/3		
630		MTMA500-40/1	29,1	218,0	15/3		
		MTMA630/1	32,5	218,5	12/3		

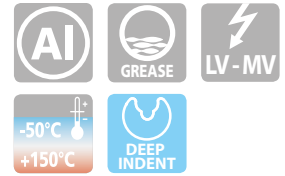

MTMA-GC series through connectors are made from Aluminium of a purity equal to or greater than 99,5%.

They feature a solid stop which creates a barrier between the two sides of conductors to be joined. Barrels are capped and filled with grease so as to avoid oxidation of the connector. MTMA/1 series through connectors are unblocked and are suitable for joining cables of the same type.

Details of the appropriate crimping tools and dies are shown on pages 318-319.

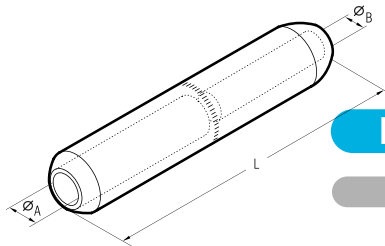

REDUCER THROUGH CONNECTORS

for Aluminium or Copper conductors

MTMA-GC



Conductor Size sqmm	Side A Al	Side B Al/Cu	Type	Dimensions mm			Quantity Box/Bag	Hydraulic Tools	
				\varnothing_A	\varnothing_B	L			
16	10		MTMA 16-10-GC	5,5	4,3	90,5	60/3	B1300-UC	
			MTMA 25-10-GC	6,5	4,3	90,5	60/3		
25	16		MTMA 25-16-GC	6,5	5,5	90,5	60/3		
			MTMA 50-25-GC	9,0	6,5	106,5	30/3		
50	35		MTMA 50-35-GC	9,0	8,0	106,5	30/3		
			MTMA 70-35-GC	11,0	8,0	106,5	30/3		
70	50		MTMA 70-50-GC	11,0	9,0	106,5	30/3		
			MTMA 95-50-GC	12,5	9,0	109,4	30/3		
95	70		MTMA 95-70-GC	12,5	11,0	106,5	30/3		
			MTMA 120-70-GC	13,7	11,0	133,0	30/3		
120	95		MTMA 120-95-GC	13,7	12,5	133,0	30/3		
			MTMA 150-70-GC	15,5	11,0	133,0	30/3		
150	95		MTMA 150-95-GC	15,5	12,5	134,4	30/3		
			MTMA 150-120-GC	15,5	13,7	133,0	30/3		
185	120		MTMA 185-120-GC	17,0	13,7	143,5	15/3		
			MTMA 185-150-GC	17,0	15,5	143,5	15/3		
240	150		MTMA 240-150-GC	19,5	15,5	143,5	15/3		
			MTMA 240-185-GC	19,5	17,0	143,5	15/3		
300	95		MTMAD 300-95-GC	22,5	12,5	144,5	15/3		
			MTMAD 300-150-GC	22,5	15,5	144,5	15/3		
300	185		MTMAD 300-185-GC	22,5	17,0	144,5	15/3		
			MTMAD 300-240-GC	22,5	19,5	144,5	15/3		
400	240		MTMA 400-240-GC	26,0	19,5	218,0	15/3		
			MTMA 400-300-GC	26,0	23,3	218,0	15/3		
500	300		MTMA 500-300-GC	29,1	23,3	218,5	12/3		
			MTMA 500-400-GC	29,1	26,0	218,5	12/3		



MTMA-GC series reducer through connectors are manufactured to the same specification as MTMA-GC series through connectors. Details of the appropriate crimping tools and dies are shown on pages 318-319.

for non-tension connections on Aluminium conductors according to DIN EN 50182

Tube dimensions according to DIN 46329

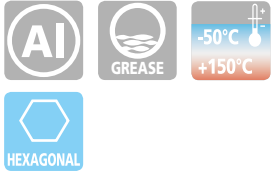
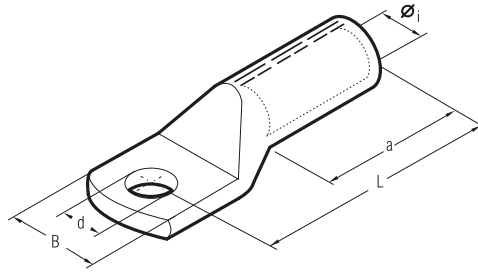

Terminals type AAD.-M.. are made from Aluminium tube of a purity equal or greater than 99,5%. They are suitable for Aluminium conductors according to DIN EN 50182, up to 10 kV.

All terminals are filled with a special grease that avoids Aluminium oxidation after crimping thereby assuring an optimal compression.

Barrel is closed with a cap for storage and transport.

Bright surface finish

The following data is stamped on the terminal:

- CEMBRE logo
- Terminal description
- Section
- Fixing bolt size
- Number and position of crimps
- CEMBRE Die reference according to DIN 48083

Details of the appropriate crimping tools and dies are shown on page 323.

Conductor Size	sqmm		Ø Stud mm	Ref.	Code	Dimensions mm					Quantity Bag	Hydraulic Tools
	rm	re				sm	se	Øi	B	L		
16	25	8		AAD16-M8	12	5,8	18	52	8,5	32	50	HT45-E B450ND-BV HT51 RH50 B500 RH60C HT60C B600CND HT 81-U RHU 81 HT 120 and tools and heads with 130 kN crimping force ECW-H3D RHU 450 RHU 520
		10		AAD16-M10	12	5,8	18	52	10,5	32	50	
25	35	8		AAD25-M8	12	6,8	19	60	8,5	37	50	
		10		AAD25-M10	12	6,8	19	60	10,5	37	50	
35	50	8		AAD35-M8	14	8,0	21	67	8,5	42	35	
		10		AAD35-M10	14	8,0	21	67	10,5	42	35	
		12		AAD35-M12	14	8,0	21	67	13,0	42	35	
50	70	8		AAD50-M8	16	9,8	25	72	8,5	42	30	
		10		AAD50-M10	16	9,8	25	72	10,5	42	30	
		12		AAD50-M12	16	9,8	25	72	13,0	42	30	
70	95	10		AAD70-M10	18	11,2	28	83	10,5	52	15	
		12		AAD70-M12	18	11,2	28	83	13,0	52	15	
		16		AAD70-M16	18	11,2	28	83	17,0	52	15	
95	120	10		AAD95-M10	22	13,2	32	90	10,5	55	10	
		12		AAD95-M12	22	13,2	32	90	13,0	55	10	
		16		AAD95-M16	22	13,2	34	90	17,0	55	10	
120	150	10		AAD120-M10	22	14,7	32	91	10,5	55	10	
		12		AAD120-M12	22	14,7	32	91	13,0	55	10	
		16		AAD120-M16	22	14,7	34	91	17,0	55	10	
150	185	10		AAD150-M10	25	16,5	35	104	10,5	60	8	
		12		AAD150-M12	25	16,5	35	104	13,0	60	8	
		16		AAD150-M16	25	16,5	35	104	17,0	60	8	
		20		AAD150-M20	25	16,5	41	104	21,0	60	8	
		12		AAD185-M12	28	18,3	40	105	13,0	60	15	
185	240	16		AAD185-M16	28	18,3	40	105	17,0	60	15	
		20		AAD185-M20	28	18,3	40	105	21,0	60	15	
		12		AAD240-M12	32	21,0	45	119	13,0	70	12	
240	300	16		AAD240-M16	32	21,0	45	119	17,0	70	12	
		20		AAD240-M20	32	21,0	45	119	21,0	70	12	
		12		AAD300-M12	34	23,3	49	125	13,0	70	9	
300		16		AAD300-M16	34	23,3	49	125	17,0	70	9	
		20		AAD300-M20	34	23,3	49	125	21,0	70	9	
		12		AAD400-M12	38	26,0	58	140	13,0	100	3	
400		16		AAD400-M16	38	26,0	58	140	17,0	100	3	
		20		AAD400-M20	38	26,0	58	140	21,0	100	3	
		12		AAD500-M12	44	29,0	63	160	13,0	100	3	
500		16		AAD500-M16	44	29,0	63	160	17,0	100	3	
		20		AAD500-M20	44	29,0	63	160	21,0	100	3	

rm = round stranded
sm = sector stranded
re = round solid
se = sector solid

ALUMINIUM THROUGH CONNECTORS

DSVA

for non-tension connections on Aluminium conductors according to DIN EN 50182

Manufactured according to DIN 46267 Part 2

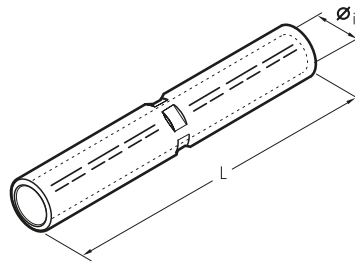

Conductor Size		Code	Ref.	Dimensions mm		Quantity Bag	Hydraulic Tools													
rm sm	re se			øi	L		HT45-E	B450ND-BV	HT51	RH50	B500	B500ND	RH60C	HT60C	B600C	B600CND	HT 81-U	RHU 81	ECW-H3D	RHU 450
16	25	12	DSVA16	5.8	55	30														
25	35	12	DSVA25	6.8	70	25														
35	50	14	DSVA35	8.0	85	25														
50	70	16	DSVA50	9.8	85	20														
70	95	18	DSVA70	11.2	105	20														
95	120	22	DSVA95	13.2	105	15														
120	150	22	DSVA120	14.7	105	15														
150	185	25	DSVA150	16.5	125	10														
185	240	28	DSVA185	18.3	125	10														
240	300	32	DSVA240	21.0	145	5														
300		34	DSVA300	23.3	145	10														
400		38	DSVA400	26.0	210	3														
		42	DSVA401	28.0	210	3														
500		44	DSVA500	29.0	210	3														
		46	DSVA501	31.0	210	3														
600		52	DSVA625	35.0	330	4														
800		58	DSVA800	40.0	350	3														
1000		60	DSVA1000	44.0	350	3														

rm = round stranded
sm = sector stranded
re = round solid
se = sector solid

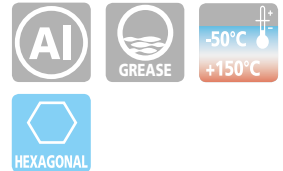

Crimping through connectors type DSV.. are manufactured according to DIN 46267 part 2.

The aluminum tube has a purity equal to or greater than 99.5%.

The crimping through connectors are suitable for aluminum conductors according to DIN EN 50182, up to 10 kV.

All connectors are filled with a special grease that avoids aluminum oxidation after crimp and thus guarantees an optimal compression.

Barrels are capped for storage and transport.

On the connector following information is shown:

- CEMBRE logo
- Connector description
- Section
- Number and position of crimps
- Compression code according to DIN 48083

Details of the appropriate crimping tools and dies are shown on page 323.

CAA-M

BIMETALLIC CONNECTORS

Copper palm fixing - Aluminium barrels

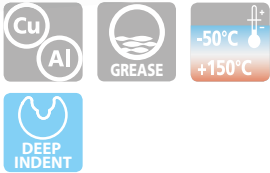
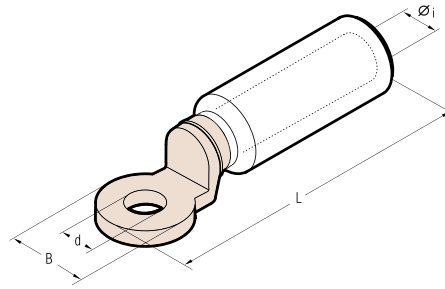

The barrels of series CAA-M connectors are made from Aluminium of a purity equal to or greater than 99,5%.

The barrel is friction welded to the palm thus achieving the best possible transition between the Copper palm and Aluminium barrel. Barrels are capped and filled with grease so as to avoid oxidation of the Aluminium.

Details of the appropriate crimping tools and dies are shown on pages 317, 319.

Conductor Size sqmm	Ø Stud mm	Type	Dimensions mm				Quantity Box/Bag	Hydraulic Tools	
			Øi	B	L	d			
10	12	CAA10-M12	4,3	24,0	87,0	13,0	90/3	HT131-UC RHU131-C B1300-UC	
16	12	CAA16-M12	5,5	24,0	87,0	13,0	90/3		
25	12	CAA25-M12	6,5	24,0	87,0	13,0	90/3		
35	12	CAA35-M12	8,0	24,0	87,0	13,0	90/3		
	12	CAA35-20-M12	8,0	24,0	87,0	13,0	60/3		
50	12	CAA50-M12	9,0	24,0	87,0	13,0	60/3		
70	12	CAA70-M12	11,0	24,0	87,0	13,0	60/3		
95	10	CAA95-M10	12,5	24,0	87,0	10,5	30/3		
	12	CAA95-M12	12,5	24,0	87,0	13,0	30/3		
120	12	CAA120-M12	13,7	31,0	111,0	13,0	24/3		
150	12	CAA150-M12	15,5	31,0	111,0	13,0	24/3		
185	12	CAA185-M12	17,0	35,0	116,0	13,0	18/3		
	12	CAA240-M12	19,5	35,0	116,0	13,0	18/3		
300	12	CAA300-34-M12	22,5	35,0	120,0	13,0	15/3	HT120 HT131-C RH131 ECW-H3D RHU230-630	
	14	CAA300-34-M14 NEW	22,5	35,0	120,0	15,0	15/3		
	16	CAA300-34-M16	22,5	35,0	120,0	17,0	15/3		
	16	CAA300-M16	23,3	35,0	152,5	16,5	9/3		
400	12	CAA400-M12	26,0	35,0	152,5	13,0	9/3		
	16	CAA400-M16	26,0	35,0	152,5	16,5	9/3		
500	16	CAA500-M16-TNBD	29,1	35,0	152,5	16,5	9/3		
630	8	CAA630-4M8	32,5	60,0	200,0	4 x 9,0*	9/3		

* 4 holes with 30 mm between axes

MTA-C

BIMETALLIC CONNECTORS

Copper pin - Aluminium barrels

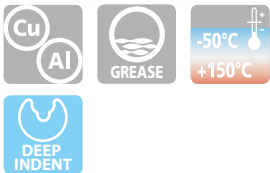
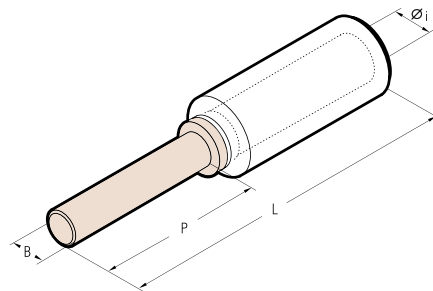

The barrels of series MTA-C connectors are made from Aluminium of a purity equal to or greater than 99,5%.

The barrel is friction welded to the pin thus achieving the best possible transition between the Copper pin and Aluminium barrel.

Barrels are capped and filled with grease so as to avoid oxidation of the Aluminium.

Details of the appropriate crimping tools and dies are shown on pages 317, 319.

Conductor Size sqmm	Type	Dimensions mm				Quantity Box/Bag	Hydraulic Tools
		Øi	B	P	L		
16	MTA16-C	5,5	8	30	82	90/3	HT131-UC RHU131-C B1300-UC
25	MTA25-C	6,5	8	30	82	90/3	
35	MTA35-C	8,0	8	30	82	90/3	
50	MTA50-C	9,0	12	45	97	60/3	
70	MTA70-C	11,0	12	45	97	60/3	
95	MTA95-C	12,5	12	45	97	60/3	
120	MTA120-C	13,7	14	55	125	30/3	
150	MTA150-C	15,5	14	55	125	30/3	
185	MTA185-C	17,0	14	55	125	24/3	
240	MTA240-C	19,5	14	55	125	24/3	

MECHANICAL LUGS

For Low and Medium voltage Al/Cu conductors

MLA-NC

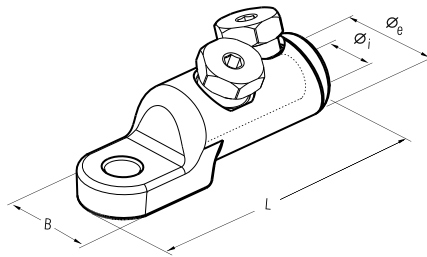

Conductor Size sqmm	Type	Ø Stud mm	Dimensions mm				N° of Bolts	Number of centring devices	Quantity Box/Bag
			Øe	Øi	B	L			
50-240	MLA50-240-12NC	12	33	20,5	33	106,5*	2	3 ● ● ●	1/10

* without centring devices



CEMBRE range-taking mechanical connectors are intended for use with Copper and Aluminium conductors, for low and medium voltage (up to 52kV) installations, in indoor, outdoor and underground applications.

Mechanical connector bodies (pic.1) are made from Aluminium EN-AW 2011 T6 with cross sectional

area and barrel length designed to optimise electrical connectivity. Internal surfaces are protected against oxidation by grease with a very high dropping point, while the Tin plating on external surfaces has a minimum thickness of 12 µm for improved surface protection.

Shear bolts (pic.2) are made from the same material and designed

to ensure a reliable electrical connection simply by tightening the bolts with a standard socket until shearing occurs inside the threaded hole without external protrusion.

To minimise voltage stresses, connectors are provided with centring devices (pic.3) to improve the alignment of the different conductor

sizes.

Key features:

- Wide range of conductor cross sections
- Suitable for Copper and Aluminium conductors
- Tested according to IEC 61238
- Torque controlled to guarantee a good electrical contact
- Reduces inventory levels
- Easy installation - only requires a standard socket
- Reduced installation time

Pic. 1



Conductor Size sqmm	Centring device	
	Color	Type
50 - 70 - 95	Red	
120 - 150	Blue	
185	Yellow	
240	Not required	

Pic. 3

ML-C

MECHANICAL LUGS WITH SYMMETRICAL PALM

For Medium voltage Al/Cu conductors

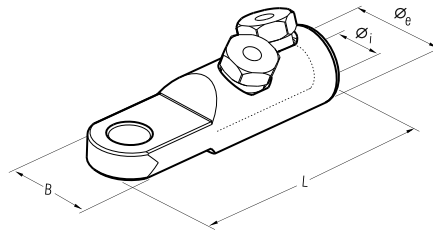

Conductor Size sqmm	Type	Ø Stud mm	Dimensions mm				N° of Bolts	Number of centring devices	Quantity Box/Bag
			Øe	Øi	B	L			
95-240	ML95-240-16C	16	35	20,5	35	124*	2	3 ● ● ●	1/10
150-240	ML150-240-16C	16	35	20,5	35	124*	2	2 ● ●	1/10

* without centring devices

MBS-NC

MECHANICAL SPLICES

For Low and Medium voltage Al/Cu conductors

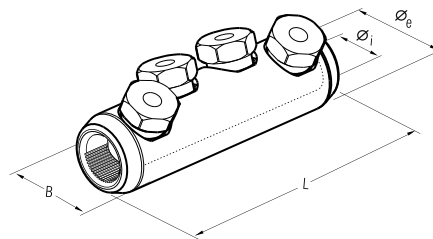

Conductor Size sqmm	Type	Dimensions mm				N° of Bolts	Number of centring devices	Quantity Box/Bag
		Øe	Øi	B	L			
50-240	MBS50-240NC	35	20,5	35	124*	4	3 ● ● ●	1/20

* without centring devices