

# TERMINAL BLOCKS, FLEXIBLE BUSBAR, BRAIDS AND DISTRIBUTION BLOCKS



## symbol description

### terminal blocks



Polycarbonate body



Zinc plated Steel screws



Polyamide PA6.6 body



Chrome plated Steel screws



Polypropylene body



Brass clamp



Steatite body



Operating temperature range



Polyvinylchloride insulating sheath



Italian Institute of the Quality Mark type approval



Electrolytically Tin plated Copper interconnections



Lloyd's Register Marine type approval



Electrolytically Tin plated to avoid oxidation



Italian Naval Register type approval



Nominal voltage V



USR-CNR type approval valid for USA and CANADA



Degree of Protection IP20



CE marking



Self-extinguishing class V0 UL94



UKCA marking

# example applications

## terminal blocks

type  
**ZETApiù®**

Z35T-11 uninterrupted,  
main earth loop, terminal block.  
Used for equipotential bonding



**UNINTERRUPTED  
MAIN EARTH  
LOOP**



Z6-10D terminal blocks  
used in a control panel.

**SUITABLE  
FOR DIN RAIL  
MOUNTING**



Z16-8D and Z6-6D  
mounted on DIN rails.  
Used in control panels

type  
**ZETAmini®**

ZETAmini terminal blocks  
used for domestic/commercial  
applications.



type  
**ZETAblock®**

A typical application of the  
Z50-DP12-160 and Z35-DP14B-125  
installed in a distribution panel



# Z6

## SINGLE POLE TERMINAL BLOCKS

indirect clamping - nominal section 6 sqmm



type  
**ZETApiù®**

The "Z...D" version has been designed for mounting on DIN rails



3, 5, 6 and 10 way, single pole terminal blocks for conductor section 1 to 6 sqmm.

Self contained and robust, they are quick and easy to install for both industrial and domestic use. The indirect clamping of the "ZETApiù" terminal blocks guarantees a low and stable contact resistance.

Indirect clamping eliminates damage to the conductor strands. The easy-entry receptacles also grant a fast and reliable insertion of the cable.

Connecting Capacity sqmm	Type	No. of Ways	Nominal Voltage V	Maximum Operating Temperature °C	Insulation Specification	Self Extinguishing Specification	Dimensions mm	Weight g	Quantity
(3 way) 1÷6	Z6-3	3	450	85	IP20	V-0 (UL 94)	23x23xh27,5	15,0	30
	Z6-3D						23x40xh36,5	18,5	10
(5 way) 1÷6	Z6-5	5	450	85	IP20	V-0 (UL 94)	35x23xh27,5	23,0	20
	Z6-5D						35x40xh36,5	26,5	10
(6 way) 1÷6	Z6-6	6	450	85	IP20	V-0 (UL 94)	23x43xh28,5	26,0	15
	Z6-6D						23x53xh33	31,0	10
(10 way) 1÷6	Z6-10	10	450	85	IP20	V-0 (UL 94)	35x43xh28,5	41,0	10
	Z6-10D						35x53xh33	46,0	15

D= Version with clamp for DIN rail

### Technical features:

- Self-extinguishing Polycarbonate body
- Tempered Steel clamps
- Electrolytically Tin plated Copper interconnections

# Z16

## SINGLE POLE TERMINAL BLOCKS

indirect clamping - nominal section 16 sqmm



type  
**ZETApiù®**



3, 4, 5, 8 and 12 way, single pole terminal blocks.

Ideal for use as an equipotential bonding connector for both industrial and domestic use.

Connecting Capacity sqmm	Type	No. of Ways	Nominal Voltage V	Maximum Operating Temperature °C	Insulation Specification	Self Extinguishing Specification	Dimensions mm	Weight g	Quantity
16	Z16-3	3	450	85	IP20	V-0 (UL 94)	38x31,3xh38	52,0	20
	Z16-3D						38x50xh44	55,5	15
16	Z16-4	4	450	85	IP20	V-0 (UL 94)	27x54xh37	50,0	15
	Z16-4D						27x58xh43	54,0	10
16	Z16-5N	5	450	85	IP20	V-0 (UL 94)	61x31,5xh38	64,5	10
	Z16-5ND						61x50xh44	68,0	4
(2 way) 16 + (6 way) 6	Z16-8	8 (2÷6)	450	85	IP20	V-0 (UL 94)	35,5x50xh36,5	50,0	15
	Z16-8D						35,5x57xh42	56,0	10
(2 way) 16 + (10 way) 6	Z16-12	12 (2÷10)	450	85	IP20	V-0 (UL 94)	104,5x32,5xh36,5	115,0	8
	Z16-12D						104,5x50xh42	125,0	5

D= Version with clamp for DIN rail

## SINGLE POLE TERMINAL BLOCKS

indirect clamping - nominal section 35 sqmm

type  
**ZETApiù®**

Z35-3



Z35-4



Z35-6



Connecting Capacity sqmm	Type	No. of Ways	Nominal Voltage V	Maximum Operating Temperature °C	Insulation Specification	Self Extinguishing Specification	Dimensions mm	Weight g	Quantity
35	Z35-3	3	450	85	IP20	V-0 (UL 94)	53x48,5xh42	110	10
	Z35-3D						53x50xh48	114	5
35	Z35-4	4	450	85	IP20	V-0 (UL 94)	37x85xh42	129	5
	Z35-4D						37x85xh48	133	5
(2 way) 35 + (4 way) 16	Z35-6	6 (2÷4)	450	85	IP20	V-0 (UL 94)	83x41xh43	130	8
	Z35-6D						83x49xh52	140	5

D= Version with clamp for DIN rail



3, 4 and 6 way, single pole terminal blocks. Ideal for use as an equipotential bonding connector for both industrial and domestic use.

## SINGLE POLE TERMINAL BLOCKS

indirect clamping - for earthing applications ⚡

type  
**ZETApiù®**

Z50-10D



Z35T-11  
Z35T-11D



Z35-26D



Connecting Capacity sqmm	Type	No. of Ways	Maximum Operating Temperature °C	Self Extinguishing Specification	Dimensions mm	Weight g	Quantity
(1 way) 35 + (10 way) 6	Z35T-11	11	85	V-0 (UL 94)	58x43xh42	70	10
	Z35T-11D	(1+10)			58x53xh47	75	10
(2 way) 35 + (24 way) 10	Z35-26D	26 (2+24)	85	V-0 (UL 94)	151x52xh48	379	4
(2 way) 50 + (8 way) 25	Z50-10D	10 (2+8)	85	V-0 (UL 94)	77,5x55xh49	320	6

D= Version with clamp for DIN rail

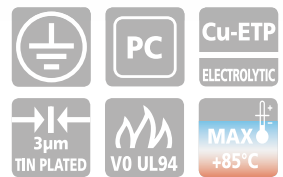



























10, 11 and 26 way, single pole terminal blocks. Ideal for use as an equipotential bonding connector for both industrial and domestic use.

# CONNECTING CAPACITY OF TERMINAL BLOCKS

indirect clamping

type  
**ZETApiù®**

Type	Nominal Section	No. of Ways x Nominal Section	Connecting Capacity of Each Way* No. of Conductors x Section	Markings
Z6-3 Z6-3D	6□	3 x 6□		   6 mm <sup>2</sup> 450 V T 85°C  
Z6-5 Z6-5D	6□	5 x 6□	1 x 6□ R/F 1 x 4□ R/F	
Z6-6 Z6-6D	6□	6 x 6□	1÷2 x 2,5□ R/F 1÷2 x 1,5□ R/F 1÷4 x 1□ R/F	   6 mm <sup>2</sup> 450 V T 85°C 
Z6-10 Z6-10D	6□	10 x 6□		
Z16-3 Z16-3D	16□	3 x 16□	1 x 16□ R/F 1 x 10□ R/F 1÷2 x 6□ R/F 1÷3 x 4□ R/F 1÷4 x 2,5□ R/F 1÷8 x 1,5□ R/F	   16 mm <sup>2</sup> 450 V T 85°C  
Z16-4 Z16-4D	16□	4 x 16□	1 x 16□ F 1 x 10□ F 1÷2 x 6□ F 1÷3 x 4□ F 1÷4 x 2,5□ F 1÷8 x 1,5□ F	
Z16-5N Z16-5ND	16□	5 x 16□	1 x 16□ R/F 1 x 10□ R/F 1÷2 x 6□ R/F 1÷3 x 4□ R/F 1÷4 x 2,5□ R/F 1÷8 x 1,5□ R/F	   16 mm <sup>2</sup> 450 V T 85°C 
Z16-8 Z16-8D	16□ / 6□	2 x 16□	1 x 16□ R/F 1 x 10□ R/F 1÷2 x 6□ R/F 1÷3 x 4□ R/F 1÷4 x 2,5□ R/F 1÷8 x 1,5□ R/F	
		6 x 6□	1 x 6□ R/F 1 x 4□ R/F 1÷2 x 2,5□ R/F 1÷2 x 1,5□ R/F 1÷4 x 1□ R/F	   16~6 mm <sup>2</sup> 450 V T 85°C 
Z16-12	16□ / 6□	2 x 16□	1 x 16□ F 1 x 10□ F 1÷2 x 6□ F 1÷3 x 4□ F 1÷4 x 2,5□ F	
Z16-12D	16□ / 6□	10 x 6□	1 x 6□ F 1 x 4□ F 1÷2 x 2,5□ F 1÷2 x 1,5□ F 1÷4 x 1□ F	   16~6 mm <sup>2</sup> 450 V T 85°C 

\* A mixture of conductor sizes may be connected to the terminal block provided that the sum of their sections is less than the nominal section.  
R = Rigid conductor    F = Flexible conductor

# CONNECTING CAPACITY OF TERMINAL BLOCKS

indirect clamping

type  
**ZETApiù®**

Type	Nominal Section	No. of Ways x Nominal Section	Connecting Capacity of Each Way* No. of Conductors x Section	Markings
Z35-3 Z35-3D	35□	3 x 35□	1 x 35□ R/F 1 x 25□ R/F 1÷2 x 16□ R/F 1÷3 x 10□ R/F 1÷5 x 6□ R/F	CE UK CA  35 mm² 450 V T 85°C
Z35-4 Z35-4D	35□	4 x 35□	1 x 35□ F 1 x 25□ F 1÷2 x 16□ F 1÷3 x 10□ F 1÷6 x 6□ F	CE UK CA  35 mm² 450 V T 85°C
Z35-6 Z35-6D	35□ / 16□	2 x 35□	1 x 35□ R/F 1 x 25□ R/F 1÷2 x 16□ R/F 1÷3 x 10□ R/F 1÷6 x 6□ F	CE UK CA  35~16 mm² 450 V T 85°C
		4 x 16□	1 x 16□ R/F 1 x 10□ R/F 1÷2 x 6□ R/F 1÷3 x 4□ R/F 1÷5 x 2,5□ F	
Z35T-11 Z35T-11D	35□ / 6□	1 x 35□	1 x 35□ R/F 1 x 25□ R/F 1 x 16□ R/F 1 x 10□ R/F	CE UK CA  35~6 mm² T 85°C
		10 x 6□	1 x 6□ R/F 1 x 4□ R/F 1÷2 x 2,5□ R/F 1÷2 x 1,5□ R/F 1÷4 x 1□ R/F	
Z35-26D	35□ / 10□	2 x 35□	1 x 35□ R/F 1 x 25□ R/F 1÷2 x 16□ R/F 1÷3 x 10□ R/F 1÷6 x 6□ R/F	CE UK CA  35~10 mm² T 85°C
		24 x 10□	1 x 10□ R/F 1 x 6□ R/F 1÷2 x 4□ R/F 1÷4 x 2,5□ R/F	
Z50-10D	50□ / 25□	2 x 50□	1 x 50□ R/F 1 x 35□ R/F 1÷2 x 25□ R/F 1÷4 x 16□ R/F	CE UK CA  ** 50~25 mm² T 85°C
		8 x 25□	1 x 25□ R/F 1÷2 x 16□ R/F 1÷3 x 10□ R/F 1÷6 x 6□ R/F 1÷9 x 4□ R/F	

\* A mixture of conductor sizes may be connected to the terminal block provided that the sum of their sections is less than the nominal section.  
R = Rigid conductor F = Flexible conductor

## MARKINGS



Italian Institute of the Quality Mark  
type approval



Lloyd's Register Marine  
type approval



Italian Naval Register  
type approval



\*\*  
EN60947-1: 2007+A1: 2011: 2014  
and EN 60947-7-1: 2002 Norms



## Conforms to:

Directive 2014/35/UE

EN 60998-1: 2004 and  
EN 60998-2-1: 2004 Norms

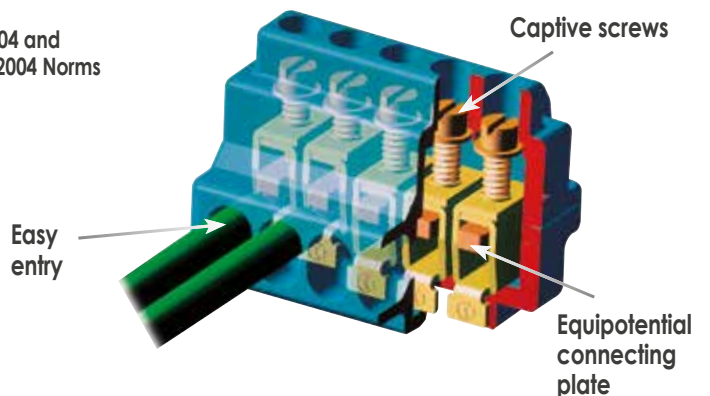

indirect clamping

type  
**ZETA**block®



Type	No. of poles	No. of Ways per pole	Nominal CSA for each pole sqmm	Maximum operating voltage (Ui)	Impulse voltage (Uimp)	Maximum operating current (In)	Allowable short duration fault current (Icw)	Maximum allowed peak fault current (Ipk)	Self Extinguishing Specification	Dimensions mm	Weight g	Qty
Z25-DP7-100	4	7 (2+5)	(2 way) 25 + (5 way) 6	800 V	8 kV	100 A	3 kA	18 kA	V-0 (UL 94)	70x84xh45	290	2
Z35-DP14-125	4	14 (2+2+10)	(2 way) 35 + (2 way) 16 + (10 way) 6	800 V	8 kV	125 A	4,2 kA	18 kA	V-0 (UL 94)	137x83xh46	700	1
Z35-DP14B-125	2	14 (2+2+10)	(2 way) 35 + (2 way) 16 + (10 way) 6	800 V	8 kV	125 A	4,2 kA	18 kA	V-0 (UL 94)	137x44xh46	360	2
Z50-DP12-160	4	12 (2+4+6)	(2 way) 50 + (4 way) 25 + (6 way) 16	800 V	8 kV	160 A	6 kA	18 kA	V-0 (UL 94)	150x84xh48	780	1

100, 125 and 160A, 2-4 pole distribution blocks with 7, 14 and 12 ways per pole respectively. Accepting a wide cable CSA range (1 - 50 sqmm) and of compact size, Zetablocks are ideal for control cabinets and distribution panels. The lateral arrangement of terminals on upper and lower faces (Z35-DP14B one face only), simplifies connection and promotes tidy, homogeneous cable routing to assist subsequent wiring operations. Easy entry apertures provide quick, effective cable insertion while the indirect clamping feature eliminates damage to cable strands and assures a low, stable contact resistance.

**Technical features:**

- Self extinguishing antishock Polycarbonate body
- Tempered Steel captive clamping screws and plates
- Electrolytically Tin plated Copper interconnectors

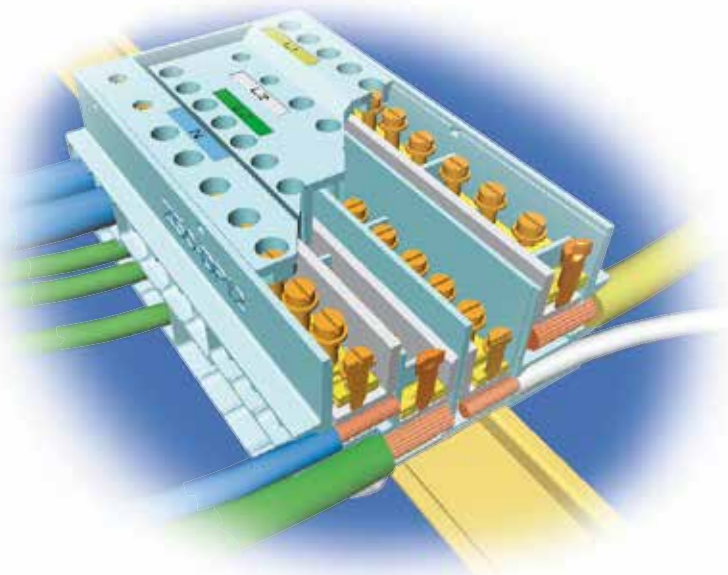

# POWER DISTRIBUTION BLOCK

Z-DP





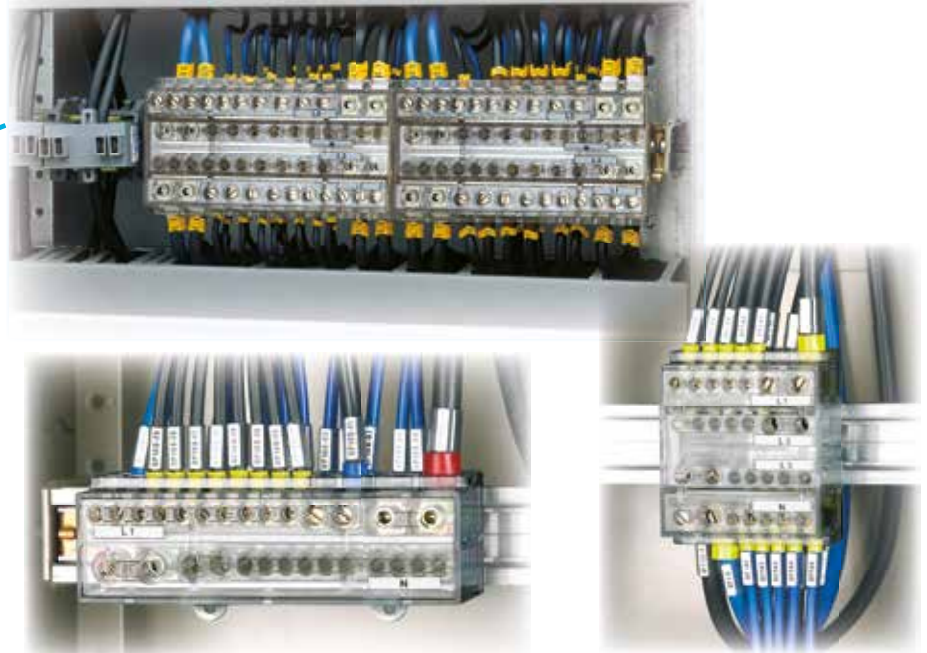



indirect clamping

type  
**ZETA**block®



## CONNECTING CAPACITY OF POWER DISTRIBUTION BLOCK

indirect clamping

Type	Nominal Section	No. of Ways x Nominal Section	Connecting Capacity of Each Way No. of Conductors x Section	Markings
Z25-DP7-100	25□/6□	2 x 25□	1 x 25□ F 1 x 16□ F 1÷2 x 10□ F	   25÷6 sqmm
		5 x 6□	1 x 6□ F 1 x 4□ F 1÷2 x 2,5□ F 1÷2 x 1,5□ F 1÷4 x 1□ F	
Z35-DP14-125 Z35-DP14B-125	35□/16□/6□	2 x 35□	1 x 35□ F 1 x 25□ F 1÷2 x 16□ F 1÷3 x 10□ F	   35÷16÷6 sqmm
		2 x 16□	1 x 16□ F 1 x 10□ F 1÷2 x 6□ F 1÷3 x 4□ F 1÷4 x 2,5□ F	
		10 x 6□	1 x 6□ F 1 x 4□ F 1÷2 x 2,5□ F 1÷2 x 1,5□ F 1÷4 x 1□ F	
Z50-DP12-160	50□/25□/16□	2 x 50□	1 x 50□ F 1 x 35□ F 1÷2 x 25□ F	   50÷25÷16 sqmm
		4 x 25□	1 x 25□ F 1 x 16□ F 1÷2 x 10□ F	
		6 x 16□	1 x 16□ F 1 x 10□ F 1÷2 x 6□ F	

F = Flexible conductor

### MARKINGS



Italian Institute of the Quality Mark  
type approval

Conforms to:  
Directive 2014/35/UE

EN 60947-7-1: 2009 Norms

indirect clamping

type  
**ZETAmini®**



Connecting Capacity sqmm	Type	Nominal Voltage V	Maximum Operating Temperature °C	Insulation Specification	Self Extinguishing Specification	Dimensions mm	Weight g	Quantity
2,5	Z2.5-1	450	85	IP20	V-0 (UL 94)	7,6x20xh23,5	3	500/25
6	Z6-1	450	85	IP20	V-0 (UL 94)	11,5x28xh29	6	250/25
10	Z10-1	450	85	IP20	V-0 (UL 94)	15,6x32xh32,5	11	80/10
16	Z16-1	450	85	IP20	V-0 (UL 94)	18x34xh38	15	60/10
25	Z25-1	450	85	IP20	V-0 (UL 94)	20,8x42,5xh43,5	29	50/10
35	Z35-1	450	85	IP20	V-0 (UL 94)	25x45xh51,5	37	40/10

One way, single pole terminal blocks for conductors sections from 0.5 to 35 sqmm.

Self contained and robust, they are ideal for the fast and safe installation for industrial and domestic applications.

The indirect clamping of the "ZETAmini" terminal blocks guarantees a low and stable contact resistance.

The easy-entry receptacle also grants a fast and reliable insertion of the cable.

Technical features:

- Self-extinguishing Polycarbonate body
- Electrolytically Zinc plated, tempered Steel clamp and screw
- Electrolytically Tin plated Steel connection plate

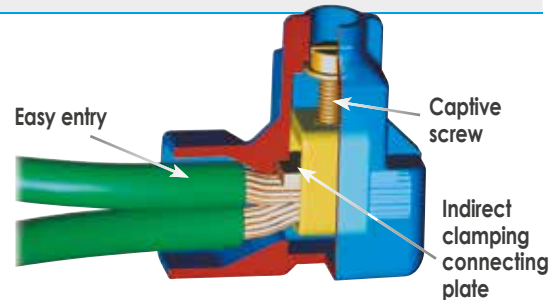

Type	Nominal Section	Connecting Capacity of Each Way* No. of Conductors x Section	Markings
Z2.5-1	2,5□	2 x 2,5□ R/F 2÷3 x 1,5□ R/F 2÷5 x 1,0□ R/F 2÷6 x 0,75□ R/F 2÷10 x 0,5□ R/F 2÷18 x Ø 0,4÷0,6 mm communication type wire	CE UK CA IP20 2,5 sqmm 450V T 85°C IP 20
Z6-1	6□	2 x 6□ R/F 2÷3 x 4□ R/F 2÷4 x 2,5□ R/F 2÷6 x 1,5□ R/F 2÷6 x 1□ R/F 2÷10 x 0,75□ R/F 2÷12 x 0,5□ R/F (1 x 6□ F) + (4 x 1,5□ F) (1 x 6□ F) + (2 x 2,5□ F)	CE UK CA IP20 6 sqmm 450V T 85°C IP 20
Z10-1	10□	2 x 10□ R/F 2÷3 x 6□ R/F 2÷5 x 4□ R/F 2÷8 x 2,5□ R/F 2÷12 x 1,5□ R/F 2÷20 x 1□ R/F 2÷25 x 0,75□ R/F (1 x 6□ F) + (1 x 4□ F) + (2 x 2,5□ F) + (3 x 1,5□ F)	CE UK CA IP20 10 sqmm 450V T 85°C IP 20
Z16-1	16□	2 x 16□ R/F 2÷3 x 10□ R/F 2÷5 x 6□ R/F 2÷8 x 4□ R/F 2÷12 x 2,5□ R/F 2÷18 x 1,5□ R/F	CE UK CA IP20 16 sqmm 450V T 85°C IP 20
Z25-1	25□	2 x 25□ R/F 2÷3 x 16□ R/F 2÷4 x 10□ R/F 2÷8 x 6□ R/F 2÷11 x 4□ R/F 4÷16 x 2,5□ R/F	CE UK CA IP20 25 sqmm 450V T 85°C IP 20
Z35-1	35□	2 x 35□ R/F 2÷3 x 25□ R/F 2÷4 x 16□ R/F 2÷7 x 10□ R/F 2÷11 x 6□ R/F 4÷17 x 4□ R/F 5÷28 x 2,5□ R/F	CE UK CA IP20 35 sqmm 450V T 85°C IP 20

\*A mixture of conductor sizes may be connected to the terminal block provided that the sum of their sections is less than twice the nominal section.

R = Rigid conductor F = Flexible conductor

Conforms to:

Directive 2014/35/UE

EN 60998-1: 2004 and  
EN 60998-2-1: 2004 Norms

## TERMINAL BLOCK TYPE EKL

# EKL

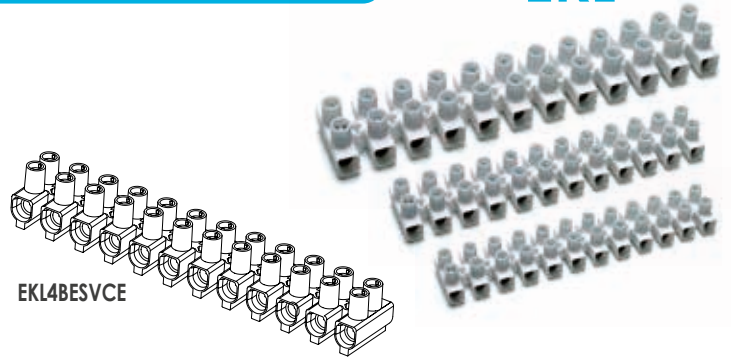
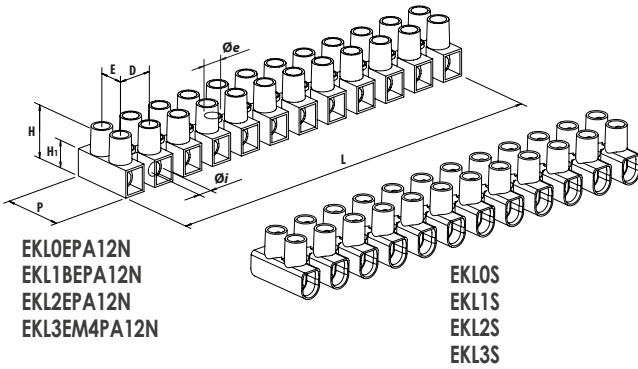

### Type 12 Poles of Polyamide (PA6.6)

Type	Nominal section sqmm	Dimensions mm								Screw	Quantity
		Øi	Øe	L 12 poles	H	H1	P	E	D		
□ EKLOEPA12N	2,5	3,0	2,6	94,0	14,5	9,2	16,4	6,0	8,0	M3	50
□ EKL1BEPA12N	4	3,4	3,2	116,2	15,7	8,3	20,2	10,0	10,0	M3	30
□ EKL2EPA12N	10	4,3	3,2	139,8	20,0	10,8	23,1	10,0	12,0	M3,5	20
□ EKL3EM4PA12N	16	5,8	4,1	171,8	24,8	14,7	32,1	13,0	14,5	M4**	25

□ Nominal voltage: 450 V  
Ambient temperature: max 110°C

\* Pending approval \*\* Combination head screws



#### Material:

- Block made of chromium plated Brass
- Screw made of chromium plated Steel

Variants upon request for version en Polyamide PA6.6

N° of poles from 1 to 11:

- replace reference 12 with n° of required poles
- Versions with protection plate: add reference "DSN"

### Type 12 Poles of Polypropylene (PP)

Type	Nominal section sqmm	Dimensions mm								Screw	Quantity
		Øi	Øe	L 12 poles	H	H1	P	E	D		
● EKLOS	4	3,2	2,65	94,9	13,0	-	16,6	6,4	8,1	M2,6	50
● EKL1S	6	3,5	3,4	116,5	14,9	-	18,9	7,3	10,0	M3	30
● EKL2S	10	4,3	3,7	133,8	17,3	-	23,4	10,0	11,5	M3,5	15
● EKL3S	16	5,5	4,9	174,5	25,0	-	20,7	11,0	15,0	M4	25
◇ EKL4BESVCE	25	7,0	4,0	187,3	28,0	-	30,0	11,0	16,0	M5	25

● Nominal voltage: 450 V  
Ambient temperature: max 80°C

◇ Nominal voltage: 750 V  
Ambient temperature: max 80°C



EKL OE PA XX XX

N° poles DSN version with protective blade

**DSN**

## TERMINAL BLOCK TYPE ZS

# ZS

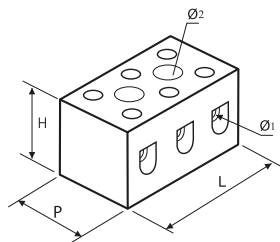

Type	Nominal section sqmm		No. of poles	Dimensions mm					Quantity
	Low Str.	Flex		Ø1	Ø2	L	H	P	
ZS-U6	4/6	4	1	2,8	-	9	18	19	200
ZS-B6	4/6	4	2	2,8	4,0	22	18	19	80
ZS-T6	4/6	4	3	2,8	4,0	36	18	19	60
ZS-U10	10	6	1	4,3	-	13	20	21	200
ZS-B10	10	6	2	4,3	4,8	24	20	21	80
ZS-T10	10	6	3	4,3	4,8	36	20	21	70
ZS-U16	16	10	1	6,1	-	15	22	27	100
ZS-B16	16	10	2	6,1	5,0	31	22	27	50
ZS-T16	16	10	3	6,1	5,0	48	22	27	30



#### Material:

- insulating body in STEATITE
- screw in GALVANIZED STEEL
- BRASS clamp

Nominal voltage: 450 V  
Operating temperature: 350°C

# DB/1N



## UNIPOLAR DISTRIBUTION BLOCKS

direct clamping

### DBLOCK UNIPOLAR SERIES

- 80, 125, 160, 250, 400, 500 A distribution blocks
- Versions available with 6, 7 or 11 outputs (see table)
- Wire entry facilitated by chamfered entry holes and clamping screws
- Terminals maintain excellent stability of the connection over time
- Connection can be expanded through dedicated unipolar jumpers (can be used for types DB125-7/1N and DB160-7/1N)



Type	N° inputs	Connecting Capacity in mm <sup>2</sup>	N° outputs	Connecting Capacity out mm <sup>2</sup>	IEC* 60947-7-1		UL* 1059		Allowable short duration fault current (Icw)	Maximum allowed peak fault current (Ipk)	Self Extinguishing Specification	Dimensions mm	Weight g	Qty
					Nominal voltage	Nominal Current	Nominal voltage	Nominal Current						
DB80-6/1N	1	6÷16	6 (4+2)	(4) 2,5÷6 (2) 2,5÷16	1000 V	80 A	600 V	85 A	3 kA	22 kA	V-0 (UL 94)	66x27xh46	70	5
DB125-7/1N	1	10÷35	7 (6+1)	(6) 2,5÷16 (1) 6÷16	1000 V	125 A	600 V	150 A	4.2 kA	30 kA	V-0 (UL 94)	77x29xh46	142	5
DB160-7/1N	1	10÷70	7 (6+1)	(6) 2,5÷16 (1) 6÷16	1000 V	160 A	600 V	200 A	11.8 kA	30 kA	V-0 (UL 94)	77x29xh46	136	5
DB250-11/1N	1	35÷120	11 (2+5+4)	(2) 6÷35 (5) 2,5÷16 (4) 2,5÷10	1000 V	250 A	600 V	255 A	24.5 kA	51 kA	V-0 (UL 94)	96x46xh50	423	3
DB400-11/1N	1	95÷185	11 (2+5+4)	(2) 6÷35 (5) 2,5÷16 (4) 2,5÷10	1000 V	400 A	600 V	335 A	24.5 kA	51 kA	V-0 (UL 94)	96x46xh50	402	3
DB500-11/1N	1	8x24 Flex. Busbar	11 (2+5+4)	(2) 6÷35 (5) 2,5÷16 (4) 2,5÷10	1000 V	500 A	600 V	335 A	24.5 kA	51 kA	V-0 (UL 94)	96x46xh50	388	3

# DB/2

## BIPOLAR DISTRIBUTION BLOCKS

direct clamping



### DBLOCK BIPOLAR SERIES

- 40, 100, 125 A bipolar distribution blocks
- Versions available with 6, 13, 14 or 15 outputs (see table)
- Wire entry facilitated by chamfered entry holes
- Terminals maintain excellent stability of the connection over time



Type	N° inputs	Connecting Capacity in mm <sup>2</sup>	N° outputs	Connecting Capacity out mm <sup>2</sup>	Nominal voltage	Nominal Current	Allowable short duration fault current (Icw)	Maximum allowed peak fault current (Ipk)	Self Extinguishing Specification	Dimensions mm	Weight g	Quantity
DB100-6/2	1	10÷25	6 (3+3)	(3) 1,5÷4 / 0,75÷4 (3) 2,5÷6 / 1,5÷6	500 V	100 A	4.5 kA	20 kA	V-0 (UL 94)	50x64xh50	110	1
DB100-13/2	2	10÷25	13 (6+7)	(6) 1,5÷4 / 0,75÷4 (7) 2,5÷6 / 1,5÷6	500 V	100 A	4.5 kA	20 kA	V-0 (UL 94)	50x130xh50	208	1
DB125-6/2	1	10÷35	6 (5+1)	(5) 2,5÷6 / 1,5÷6 (1) 10÷25 / 6÷16	690 V	125 A	4.5 kA	18 kA	V-0 (UL 94)	50x94xh50	160	1
DB125-14/2	1	10÷35	14 (11+3)	(11) 2,5÷6 / 1,5÷6 (3) 10÷25 / 6÷16	690 V	125 A	4.5 kA	18 kA	V-0 (UL 94)	50x162xh50	266	1
DB125-14/2C	2	10÷35 10÷16	13 (11+2)	(11) 2,5÷6 / 1,5÷6 (2) 10÷25 / 6÷16	500 V	125 A	4.5 kA	20 kA	V-0 (UL 94)	50x130xh50	204	1

## TETRAPOLAR DISTRIBUTION BLOCKS

# DB/4

direct clamping



### DBLOCK TETRAPOLAR

- 40, 100, 125, 160 A distribution blocks
- Versions available with 6, 13, 14 or 15 outputs (see table)
- Wire entry facilitated by chamfered entry holes
- Terminals maintain excellent stability of the connection over time

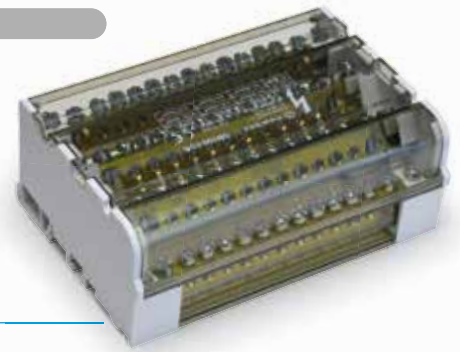

Type	N° inputs	Connecting Capacity in mm²	N° outputs	Connecting Capacity out mm²	Nominal voltage	Nominal Current	Allowable short duration fault current (I <sub>cs</sub> )	Maximum allowed peak fault current (I <sub>pk</sub> )	Self Extinguishing Specification	Dimensions mm	Weight g	Quantity
DB40-11/4	2	6÷16 4÷10	11	1,5÷4 / 0,75÷4	500 V	40 A	4.5 kA	22 kA	V-0 (UL 94)	90x100xh50	351	1
DB100-6/4	1	10÷25	6 (3+3)	(3) 1,5÷4 / 0,75÷4 (3) 2,5÷6 / 1,5÷6	500 V	100 A	4.5 kA	20 kA	V-0 (UL 94)	90x64xh50	230	1
DB100-13/4	2	10÷25	13 (6+7)	(6) 1,5÷4 / 0,75÷4 (7) 2,5÷6 / 1,5÷6	500 V	100 A	4.5 kA	20 kA	V-0 (UL 94)	90x130xh50	444	1
DB125-6/4	1	10÷35	6 (5+1)	(5) 2,5÷6 / 1,5÷6 (1) 10÷25 / 6÷16	690 V	125 A	4.5 kA	20 kA	V-0 (UL 94)	90x109xh50	326	1
DB125-10/4	1	10÷35	10 (7+3)	(7) 2,5÷6 / 1,5÷6 (3) 10÷25 / 6÷16	690 V	125 A	4.5 kA	20 kA	V-0 (UL 94)	90x147xh50	440	1
DB125-10/4C	2	10÷35 10÷16	9 (7+2)	(7) 2,5÷6 / 1,5÷6 (2) 10÷25 / 6÷16	500 V	125 A	4.5 kA	20 kA	V-0 (UL 94)	90x100xh50	306	1
DB125-14/4	1	10÷35	14 (11+1+2)	(11) 2,5÷6 / 1,5÷6 (1) 10÷25 / 6÷16 (2) 10÷35 / 10÷25	690 V	125 A	4.2 kA	14.5 kA	V-0 (UL 94)	90x182xh50	586	1
DB125-14/4C	2	10÷35 10÷16	13 (11+2)	(11) 2,5÷6 / 1,5÷6 (2) 10÷25 / 6÷16	500 V	125 A	4.5 kA	20 kA	V-0 (UL 94)	90x130xh50	398	1
DB160-11/4	1	10÷50	11 (3+7+1)	(3) 10÷35 / 10÷25 (7) 2,5÷6 / 1,5÷6 (1) 2,5÷6 / 1,5÷6	690 V	160 A	8.2 kA	35 kA	V-0 (UL 94)	96x175xh50	738	1



## ACCESSORIES

neutral bars



Type	N° inputs	Connecting Capacity in mm²	N° outputs	Connecting Capacity out mm²	Nominal voltage	Nominal Current	Allowable short duration fault current (I <sub>cs</sub> )	Maximum allowed peak fault current (I <sub>pk</sub> )	Type Application	Length mm	Weight g	Quantity
DNB125-9	4	10÷25 / 6÷16	9	2,5÷6 / 1,5÷6	-	125 A	4.5 kA	30 kA	DB125-10/4 DB125-14/4	142	172	1
DNB160-10	4	10÷35 / 10÷25	10	2,5÷16 / 1,5÷16	-	160 A	6.2 kA	35 kA	DB160-11/4	168	192	1



unipolar jumper



Type	Nominal Current	Type Application	Length mm	Weight g	Quantity
DJ160	125 A - 160 A	DB125-7/1N - DB160-7/1N	37	29	5



# DJ160